

YUTAKI S80 SERIES

**Technical Catalogue**

---

RWH-(4.0-6.0)FS(V)NFE Indoor unit  
RAS-(4-6)H(V)RNME-AF Outdoor unit  
DHWS-(195/260)S-2.0H1E DHW tank  
PC-S80TE LCD controller

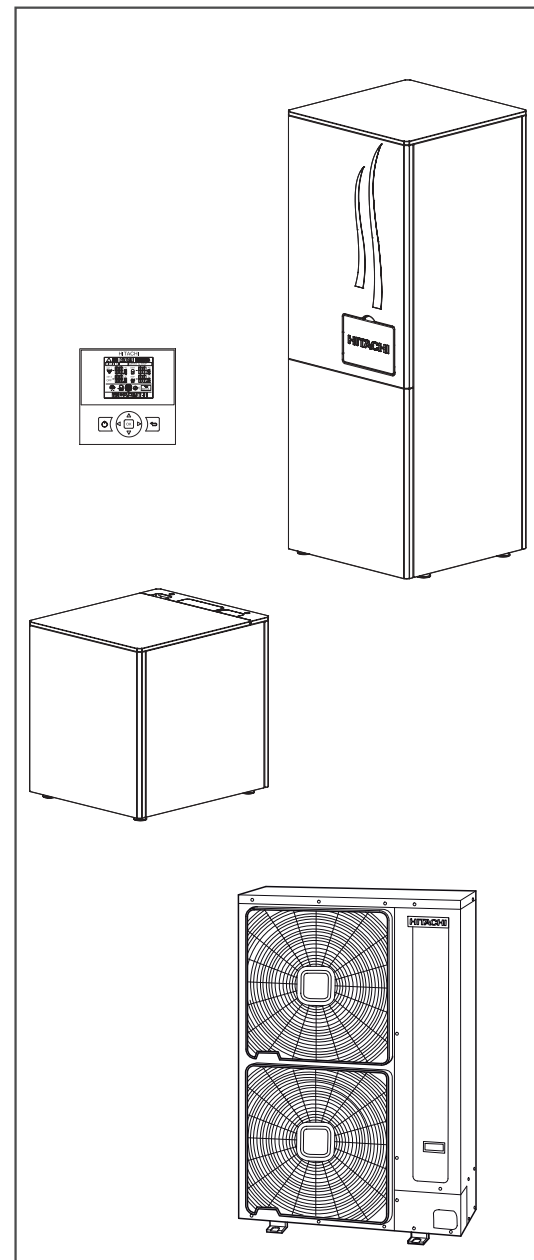



---

**Contents**

---

<b>General information</b>	<b>1</b>
<b>Features and benefits</b>	<b>2</b>
<b>General data</b>	<b>3</b>
<b>Capacities and Selection data</b>	<b>4</b>
<b>Acoustic characteristic curves</b>	<b>5</b>
<b>Working range</b>	<b>6</b>
<b>General dimensions</b>	<b>7</b>
<b>Refrigerant cycle</b>	<b>8</b>
<b>Piping work and refrigerant charge</b>	<b>9</b>
<b>Electrical wiring</b>	<b>10</b>
<b>Installation configurations</b>	<b>11</b>
<b>Optional functions</b>	<b>12</b>
<b>Troubleshooting</b>	<b>13</b>



## General Index

<b>Contents .....</b>	<b>3</b>
<b>1. General information .....</b>	<b>9</b>
1.1 General information .....	10
1.1.1 General notes .....	10
1.1.2 Introduction .....	10
1.1.3 Environment-friendly units .....	11
1.2 Applied symbols .....	12
1.3 Product guide .....	13
1.3.1 Product guide .....	13
1.3.2 Model's classification .....	15
1.3.3 Accessory code list .....	16
<b>2. Features and benefits .....</b>	<b>19</b>
2.1 Main features .....	20
2.2 Selection benefits .....	21
2.2.1 Environment-friendly system .....	21
2.2.2 Water outlet temperature up to 80 °C .....	22
2.2.3 SMART cascade cycle .....	23
2.2.4 High efficiency system .....	25
2.2.5 Wide capacity range .....	25
2.2.6 Nominal heating capacity stable at low outdoor ambient temperatures .....	26
2.2.7 Adaptability to the customer's/system needs .....	26
2.2.8 Wide range of accessories .....	26
2.2.9 Advanced technology .....	27
2.3 Installation benefits .....	37
2.3.1 Different possible installation types .....	37
2.3.2 Easy unit installation .....	38
2.3.3 Easy and flexible electrical installation .....	39
2.4 Start-up benefits .....	40
2.4.1 Start-up by pressing the Run/Stop button of LCD user's interface .....	40
2.4.2 Floor screed drying (Circuits 1 & 2) (Optional function) .....	40
2.4.3 Test run operation from LCD user's interface .....	40
2.5 Control features .....	41
2.5.1 Easy to use - New LCD user's interface (PC-S80TE) .....	41
2.6 Control features .....	43
2.6.1 Flexible space heating configuration and control .....	43

2.6.2 Flexible Domestic Hot Water (DHW) control .....	47
2.6.3 Swimming pool combination control .....	49
2.6.4 Flexible water pumps control.....	49
2.6.5 Other optional functions .....	49
<b>2.7 Maintenance benefits.....</b>	<b>51</b>
2.7.1 Complete operation display by LCD user's interface .....	51
2.7.2 Front access to the electrical box.....	51
2.7.3 Easy servicing .....	52
2.7.4 High accessibility to the water pressure ports .....	52
2.7.5 Alarm hystorical data .....	53
<b>3 ■ General data.....</b>	<b>55</b>
3.1 YUTAKI S80 system .....	56
3.2 Outdoor unit.....	57
3.2.1 RAS-(4-6)HVRNME-AF .....	57
3.2.2 RAS-(4-6)HRNME-AF .....	58
3.3 Indoor unit.....	59
3.3.1 RWH-(4.0-6.0)FSVNFE .....	59
3.3.2 RWH-(4.0-6.0)FSNFE .....	60
3.4 Domestic Hot Water Tank .....	61
3.5 Component data .....	62
3.5.1 Outdoor unit.....	62
3.5.2 Indoor unit .....	64
3.6 Electrical data .....	65
3.6.1 Considerations .....	65
3.6.2 Outdoor unit.....	65
3.6.3 Indoor unit .....	65
3.6.4 Domestic Hot Water Tank - Electrical heater .....	66
<b>4 ■ Capacity and selection data .....</b>	<b>67</b>
4.1 System selection procedure .....	68
4.1.1 Selection parameters .....	68
4.1.2 Selection procedure .....	68
4.2 Maximum heating capacity tables.....	76
4.3 Correction factors .....	77
4.3.1 Defrost correction factor .....	77
4.3.2 Piping length correction factor.....	77

<b>5. Acoustic characteristic curves .....</b>	<b>79</b>
5.1 Sound pressure level for outdoor unit.....	80
5.1.1 Considerations .....	80
5.1.2 Charts.....	81
<b>6. Working range .....</b>	<b>83</b>
6.1 Working range .....	84
<b>7. General dimensions .....</b>	<b>85</b>
7.1 Name of parts .....	86
7.1.1 Outdoor unit.....	86
7.1.2 Indoor unit .....	87
7.1.3 Domestic Hot Water Tank.....	88
7.2 Dimensional data .....	89
7.2.1 Outdoor unit.....	89
7.2.2 Indoor unit and domestic hot water tank (optional) .....	89
7.3 Service space .....	91
7.3.1 Outdoor unit.....	91
7.3.2 Indoor unit and domestic hot water tank (optional) .....	92
<b>8. Refrigerant cycle and hydraulic circuit .....</b>	<b>95</b>
8.1 RAS-(4-6)H(V)RNME-AF + RWH-(4.0-6.0)FS(V)NFE combination .....	96
<b>9. Refrigerant and water piping.....</b>	<b>97</b>
9.1 Refrigerant circuit.....	98
9.1.1 Refrigerant piping .....	98
9.1.2 Piping connections .....	99
9.1.3 Refrigerant charge.....	100
9.1.4 Precautions in the event of gas refrigerant leaks .....	100
9.1.5 Pump down of refrigerant.....	102
9.1.6 Refrigerant check joints.....	102
9.2 Space heating hydraulic circuit.....	103
9.2.1 Hydraulic circuit .....	103
9.2.2 Water piping .....	104
9.2.3 Water quality.....	105
9.2.4 Water flow adjustment .....	105
9.2.5 Pressure charts .....	107
9.3 Domestic Hot Water hydraulic circuit (Optional) .....	108
9.3.1 Hydraulic circuit .....	108

9.3.2	Water piping .....	110
9.3.3	Water quality.....	112
<b>10.</b>	<b>Electrical wiring.....</b>	<b>113</b>
10.1	Unit electrical wiring and connection .....	114
10.1.1	General check .....	114
10.2	Electrical wiring connection .....	116
10.2.1	Outdoor unit terminal board connections .....	116
10.2.2	Indoor unit terminal board connections .....	117
10.3	Printed circuit board (PCB).....	118
10.3.1	Outdoor unit.....	118
10.3.2	Indoor unit .....	119
10.4	Setting of DIP switches and RSW switches.....	121
10.4.1	Outdoor unit.....	121
10.4.2	Indoor unit .....	124
10.5	Common wiring.....	130
10.5.1	Electrical wiring between indoor and outdoor unit of the air to water heat pump system.....	130
10.5.2	Electrical wiring between DHW tank and indoor unit.....	133
<b>11.</b>	<b>Installation configuration.....</b>	<b>135</b>
11.1	System configurations.....	136
11.2	Installation configurations .....	138
11.2.1	Main configurations .....	139
11.2.2	Additional combinations.....	142
<b>12.</b>	<b>Optional functions.....</b>	<b>147</b>
12.1	Indoor unit.....	148
12.1.1	Optional functions.....	148
12.1.2	Optional external output signals (by 7-segment display).....	149
12.2	Outdoor unit.....	149
12.2.1	Optional functions.....	149
<b>13.</b>	<b>Troubleshooting .....</b>	<b>151</b>
13.1	Troubleshooting procedure by alarm code .....	152
13.1.1	Alarm display .....	152
13.1.2	Alarm codes.....	153



# 1. General information

## Index

1.1. General information.....	10
1.1.1. General notes.....	10
1.1.2. Introduction.....	10
1.1.3. Environment-friendly units.....	11
1.2. Applied symbols.....	12
1.3. Product guide.....	13
1.3.1. Product guide.....	13
1.3.2. Model's classification.....	15
1.3.3. Accessory code list.....	16

1

## 1.1 General information

---

### 1.1.1 General notes

No part of this publication may be reproduced, copied, filed or transmitted in any shape or form without the permission of HITACHI Air Conditioning Products Europe, S.A.

Within the policy of continuous improvement of its products, HITACHI Air Conditioning Products Europe, S.A. reserves the right to make changes at any time without prior notification and without being compelled to introducing them into products subsequently sold. This document may therefore have been subject to amendments during the life of the product.

HITACHI makes every effort to offer correct, up-to-date documentation. Despite this, printing errors cannot be controlled by HITACHI and are not its responsibility.

As a result, some of the images or data used to illustrate this document may not refer to specific models. No claims will be accepted based on the data, illustrations and descriptions included in this manual.

No type of modification must be made to the equipment without prior, written authorization from the manufacturer.



#### NOTE

***This air conditioner has been designed for standard air conditioning for human beings. For use in other applications, please contact your HITACHI dealer or service contractor.***



#### CAUTION

***This unit is designed for commercial and light industrial application. If installed in house hold appliance, it could cause electromagnetic interference.***

### 1.1.2 Introduction

HITACHI is introducing another innovative heat pump to its award-winning YUTAKI range. The YUTAKI S80 will generate hot water up to 80°C; the hottest water temperature on the domestic heating market using renewable energy.

The YUTAKI air to water heat pump has a high COP, and this new innovation makes further strides in seasonal efficiency.

HITACHI's YUTAKI heat pumps produce sanitary hot water and heating like any oil or gas boiler but transforms renewable energy from the air outside into heat. Every 1kW of electricity used to power the heat pump can provide up to 4kW of energy for heating; this can reduce heating bills by up to 60% and cut CO<sub>2</sub> emissions by 50% compared to traditional boiler-led systems.

The extra innovation in the YUTAKI S80 is that it has two compressors, working in a smart cascade system, with two refrigerant cycles (R-410A and R-134a). To maximize seasonal efficiency, the second refrigerant cycle is only operated as a booster, when very high water temperature is required - the rest of the time, only one cycle is used.

The YUTAKI S80 will be ideal for existing properties, in particular older establishments where higher water supply temperatures may be required to keep the house warm – as well as for new builds. It is designed for boiler substitution, offering heating and sanitary hot water all year round, without boiler back-up.

The YUTAKI S80 is easy to install and operate; it's a split system, using HITACHI's IVX outdoor unit with a brand new standalone indoor unit.

Six different models are available in single phase or three phase versions. The indoor unit is a standard width of <600 mm allowing seamless integration into kitchens and utility rooms.

For DHW operation (optional), HITACHI offers two DHW tanks (DHWS195S-2.0H1E and DHWS260S-2.0H1E) with the possibility to combine with the indoor unit as integrated over it or beside it, allowing the user to benefit from the heat pump's high efficiency and achieve hot water up to 75°C.

The DHW tank is made with high advanced technology using stainless steel chemically descaled and passivated materials. It has been designed to be high thermal efficient insulated with rigid, mould-injected, Neopor EPS in grey colour.

The DHW Tank has been designed to have a compact size to reduce the installation space and to eliminate the cold zones at the bottom of the storage tank to prevent the risk of bacteria proliferation (e.g. Legionella).

The system is simple to control; its wireless remote controller (PC-S80TE) is a variation of the well-received and successful design used with the existing YUTAKI S system, which includes a helpful LCD graphic display, one-touch holiday button, weekly timer and frost protection.

#### ◆ Additional combinations

YUTAKI S80 system can be used for the following additional combinations:

##### **Solar combination for DHW**

YUTAKI S80 system can be combined with solar panel.

The solar combination will enable to heat up the DHW by means of the sun. The solar combination is designed to transfer the heat from the solar panels (sun radiation) to the heat exchanger of DHW tank.

##### **Swimming pool operation**

YUTAKI S80 can also be used to heat up the swimming pool water temperature up to a value between 24 and 33°C.

### **1.1.3 Environment-friendly units**

The new HITACHI's YUTAKI S80 series uses environmentally-friendly R410A / R134a gas refrigerants, and the RoHS and Green Dot regulations are applied throughout the manufacturing and installation process to reflect HITACHI's awareness of environmental respect and commitment.

R410A and R134a are totally environmentally-friendly since it does not contain any substances that damage the ozone layer: ODP (ozone depleting potential) =0.

HITACHI's YUTAKI S80 series are very efficient and allow significant energy savings compared with conventional systems. This energy efficiency means less production of CO<sub>2</sub>, which causes the greenhouse effect.



## 1.2 Applied symbols

---

During normal air conditioning system design work or unit installation, greater attention must be paid in certain situations requiring particular care in order to avoid damage to the unit, the installation or the building or property.

Situations that jeopardise the safety of those in the surrounding area or that put the unit itself at risk will be clearly indicated in this manual.

To indicate these situations, a series of special symbols will be used to clearly identify these situations.

Pay close attention to these symbols and to the messages following them, as your safety and that of others depends on it.

### **DANGER**

- *The text following this symbol contains information and instructions relating directly to your safety and physical wellbeing.*
- *Not taking these instructions into account could lead to serious, very serious or even fatal injuries to you and others in the proximities of the unit.*

In the texts following the danger symbol you can also find information on safe procedures during unit installation.

### **CAUTION**

- *The text following this symbol contains information and instructions relating directly to your safety and physical wellbeing.*
- *Not taking these instructions into account could lead to minor injuries to you and others in the proximities of the unit.*
- *Not taking these instructions into account could lead to unit damage.*

In the texts following the caution symbol you can also find information on safe procedures during unit installation.

### **NOTE**

- *The text following this symbol contains information or instructions that may be of use or that require a more thorough explanation.*
- *Instructions regarding inspections to be made on unit parts or systems may also be included.*

## 1.3 Product guide



### 1.3.1 Product guide

#### ◆ Outdoor unit

Outdoor unit 			
Single phase (1~ 230V 50Hz)		Three phase (3N~ 400V 50Hz)	
Unit	Code	Unit	Code
RAS-4HVRNME-AF	7E300020	RAS-4HRNME-AF	7E300120
RAS-5HVRNME-AF	7E300021	RAS-5HRNME-AF	7E300121
RAS-6HVRNME-AF	7E300022	RAS-6HRNME-AF	7E300122



#### ◆ Indoor unit

Indoor unit   			
Single phase (1~ 230V 50Hz)		Three phase (3N~ 400V 50Hz)	
Unit	Code	Unit	Code
RWH-4.0FSVNFE	7E480007	RWH-4.0FSNFE	7E480107
RWH-5.0FSVNFE	7E480008	RWH-5.0FSNFE	7E480108
RWH-6.0FSVNFE	7E480009	RWH-6.0FSNFE	7E480109





◆ Domestic hot water tank (DHWT)

Domestic hot water tank			
Single phase (1~ 230V 50Hz)			
Unit	Code	Unit	Code
DHWS195S-2.0H1E (*)	7E544102	DHWS260S-2.0H1E (*)	7E544103
			

**i** NOTE

(\*): Models with integrated LCD controller (PC-S80TE).

◆ LCD controller

LCD controller	
Unit	Code
PC-S80TE (*)	7E543001
	

**i** NOTE

(\*): For indoor unit alone (without tank) or indoor unit with other tank (non HITACHI tank beside the indoor unit), the LCD controller is needed.

### 1.3.2 Model's classification

#### ◆ Classification of outdoor unit model

Unit type: Outdoor unit										
Position-separating hyphen (fixed)										
Compressor power (HP): 4, 5, 6.										
Heat pump										
V= Single phase unit (1~ 230V 50Hz)										
- = Three phase unit (3N~ 400V 50Hz)										
Inverter system										
R410A refrigerant										
IVX series										
Made in Europe										
RAS	-	X	H	(X)	R	N	M	E	-AF	YUTAKI (S/S80)

#### ◆ Classification of indoor unit model

Unit type: indoor unit water module - high temperature										
Position-separating hyphen (fixed)										
Compressor power (HP): 4.0, 5.0, 6.0.										
System Free										
V = Single phase unit (1~ 230V 50Hz)										
- = Three phase unit (3N~ 400V 50Hz)										
R-410A refrigerant										
R-134a refrigerant										
Made in Europe										
RWH	-	X.X	FS	(X)	N	F	E			

#### ◆ Classification of Domestic Hot Water Tank accessory

Unit type: YUTAKI S80 domestic hot water tank										
Model: 195/260										
Stainless										
Position-separating hyphen (fixed)										
Electric heater of 2.0 kW										
Series										
Made in Europe										
DHWS	XXX	S	-	2.0H	1	E				



#### ◆ Classification of LCD user controller

Unit type: Individual remote controller										
Position-separating hyphen (fixed)										
YUTAKI S80										
Timer										
Made in Europe										
PC	-	S80	T	E						







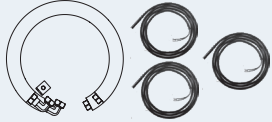

### 1.3.3 Accessory code list

#### ◆ Room Thermostats

Accessory	Name	Code	Figure
ATW-RTU-01	ON/OFF Thermostat (Receiver + Room Thermostat)	7E543000	
ATW-RTU-02	“Intelligent” Thermostat (Receiver + Room Thermostat)	7E549900	
ATW-RTU-03	2nd temperature Thermostat (Only Room Thermostat) *Only for “Intelligent” Thermostat application	7E549901	

#### ◆ Other accessories

Accessory	Name	Code	Figure
ATW-FWP-01	Tank beside the indoor unit installation kit	7E549915	
WEH-6E	Water electric heater	90500002 (WEH-6E)	
ATW-HSK-01 (BDHM1)	Hydraulic separator	7E549905 (BDHM1)	
ATW-3WV-01 (VID3V1)	3-way valve (Type 1) (Internal thread and spring return)	7E549906 (VID3V1)	
ATW-3WV-02	3-way valve (Type 2) (External thread and 2 points SPST)	7E549914	
ATW-AOS-01	Auxilliary output signal box (Relay board for additional output signals)	7E549910	



Accessory	Name	Code	Figure
ATW-2KT-01 (CDH2Z1)	2nd. temperature kit (*)	7E549904 (CDH2Z1)	
ATW-MVM-01	Mixing valve motor	7E549912	
ATW-AQT-01 (ASMSH1)	Aquastat	7E549907 (ASMSH1)	
ATW-2OS-01	Ambient temperature sensor (2nd. outdoor temperature sensor)	7E549909	
ATW-SPS-01	Swimming pool sensor	7E549908	
ATW-WTS-02	Water temperature sensor (Second temperature control)	7E549911	
ATW-WTS-02Y	Universal water temperature sensor (DHW, boiler and electric heater combination)	9E500004	
ATW-WCV-01	Water check valve	9E500014	
DHWT-SWG-01	Security water valve for DHW tank	70544902	

**i NOTE**

(\*): *The 2nd temperature kit (ATW-2KT-01) must be installed with the following accessories:*

- *Mixing valve motor (ATW-MVM-01)*
- *Water temperature sensor for second temperature control (ATW-WTS-02)*
- *Aquastat for heating floor protection (ATW-AQT-01)*

*All these products are separately sold.*



## 2. Features and benefits

2

### Index

2.1.	Main features.....	20
2.2.	Selection benefits.....	21
2.2.1.	Environment-friendly system.....	21
2.2.2.	Water outlet temperature up to 80 °C.....	22
2.2.3.	SMART cascade cycle.....	23
2.2.4.	High efficiency system.....	25
2.2.5.	Wide capacity range.....	25
2.2.6.	Nominal heating capacity stable at low outdoor ambient temperatures.....	26
2.2.7.	Adaptability to the customer's/system needs.....	26
2.2.8.	Wide range of accessories.....	26
2.2.9.	Advanced technology.....	27
2.3.	Installation benefits.....	37
2.3.1.	Different possible installation types.....	37
2.3.2.	Easy unit installation.....	38
2.3.3.	Easy and flexible electrical installation.....	39
2.4.	Start-up benefits.....	40
2.4.1.	Start-up by pressing the Run/Stop button of LCD user's interface.....	40
2.4.2.	Floor screed drying (Circuits 1 & 2) (Optional function).....	40
2.4.3.	Test run operation from LCD user's interface.....	40
2.5.	Control features.....	41
2.5.1.	Easy to use - New LCD user's interface (PC-S80TE).....	41
2.6.	Control features.....	43
2.6.1.	Flexible space heating configuration and control.....	43
2.6.2.	Flexible Domestic Hot Water (DHW) control.....	47
2.6.3.	Swimming pool combination control.....	49
2.6.4.	Flexible water pumps control.....	49
2.6.5.	Other optional functions.....	49
2.7.	Maintenance benefits.....	51
2.7.1.	Complete operation display by LCD user's interface.....	51
2.7.2.	Front access to the electrical box.....	51
2.7.3.	Easy servicing.....	52
2.7.4.	High accessibility to the water pressure ports.....	52
2.7.5.	Alarm historical data.....	53

## 2.1 Main features

### YUTAKI S80

- 1 Water outlet temperature up to 80 °C even in very low ambient temperature conditions of -20 (°C WB). The best solution to replace existing boilers which work on systems with old radiators and weak isolation.
- 2 SMART cascade cycle, which combines the best performance of 1 cycle (R410A-H<sub>2</sub>O for low water temperatures) and 2 cycles (R410A-R134a and R134a-H<sub>2</sub>O for high water temperatures), providing a better COP than conventional systems.
- 3 The highest COP in the most common conditions and the highest heating capacity at high water outlet temperatures for a wide range of outdoor temperatures, including very cold conditions.
- 4 Heating capacity stable at low outdoor ambient temperatures; use of water electric heater or boiler highly reduced.
- 5 Wide operation possibilities (space heating, domestic hot water operation, combinability with solar energy, combinable with an existing boilers or electric heater) and different heating systems (radiator/fan coil, heating floor or both (2nd temperature area)).
- 6 Floor standing structure with high installation possibilities (Indoor unit alone (without tank), Indoor unit with HITACHI tank (Tank integrated over the indoor unit), Indoor unit with HITACHI tank (Tank beside the indoor unit) and Indoor unit with other tank (Non HITACHI tank beside the indoor unit).
- 7 Compact size (595 mm width), very suitable for indoor utility room (<600 mm).
- 8 Easy servicing, allowing that the most important components can be accessible and extracted from the front side of the unit. For example, the electrical box can be easily extracted from the unit's front side due to a wire-to-wire connection.
- 9 Flexible water piping, for situations where by installation restrictions, handling of rigid piping could be complicated.
- 10 Easy wiring: big terminal board with a schematic label which makes the wiring installation easy.
- 11 Unit timer for heating space, DHW and swimming pool in order to enable/disable the operation depending on the day or the time slot.
- 12 Easy to use LCD user's interface (PC-S80TE) with a really complete display menu for comprehensive view and with the possibility to check all the important parameters and status of the unit in any moment.
- 13 Three different possible water outlet temperature set-point configuration modes for each zone (OTC points, OTC gradient and fixed temperature).
- 14 A large variety of control functions, with special functions like "Floor screed drying", "DHW Anti-Legionella protection", etc.

### NOTE

*The specific information about these points will be detailed throughout this chapter.*

## 2.2 Selection benefits

### 2.2.1 Environment-friendly system

#### ◆ Free energy

The air to water heat pump extracts the free energy present in the air, which is enough to heat a home up to a comfortable temperature, even on the coldest winter day.

The air to water heat pump can attain efficiency of over 4.0. This means less electrical consumption and therefore a reduction in CO<sub>2</sub> emissions.

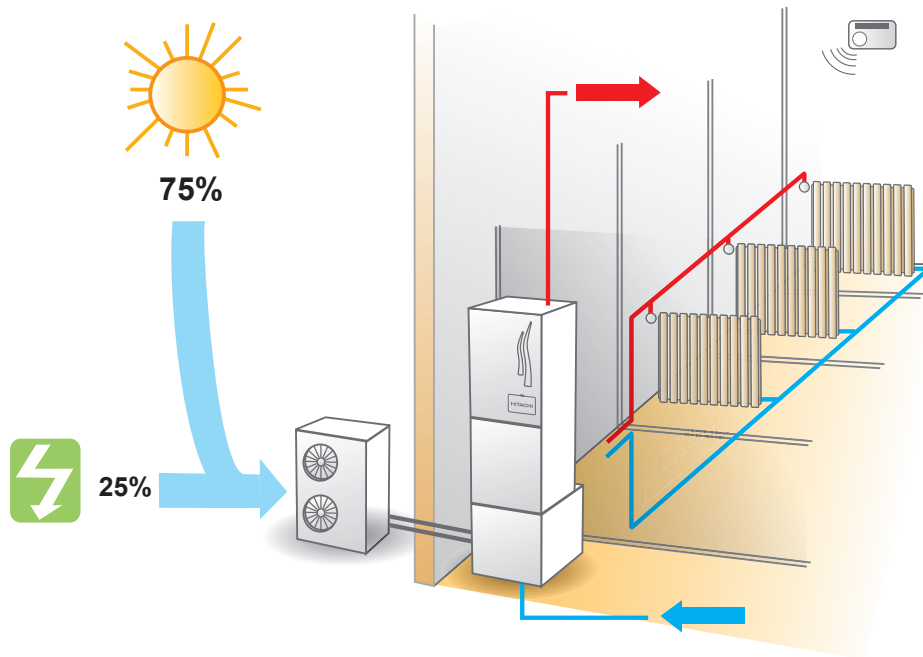

#### ◆ Combinability with solar energy

YUTAKI S80 allows the combination with solar panels for the Domestic Hot Water operation. The air to water heat pump will provide a part of the required heating, and the rest of required heating will be provided by the solar panel.

As it is known, the solar panels get the heat from the solar radiation, resulting in an environment friendly system.

#### **i** NOTE

**Not available when the HITACHI domestic hot water tank is integrated over the indoor unit.**

### 2.2.2 Water outlet temperature up to 80 °C

Water outlet temperature up to 80 °C even in very low ambient temperature conditions of -20 (°C WB).

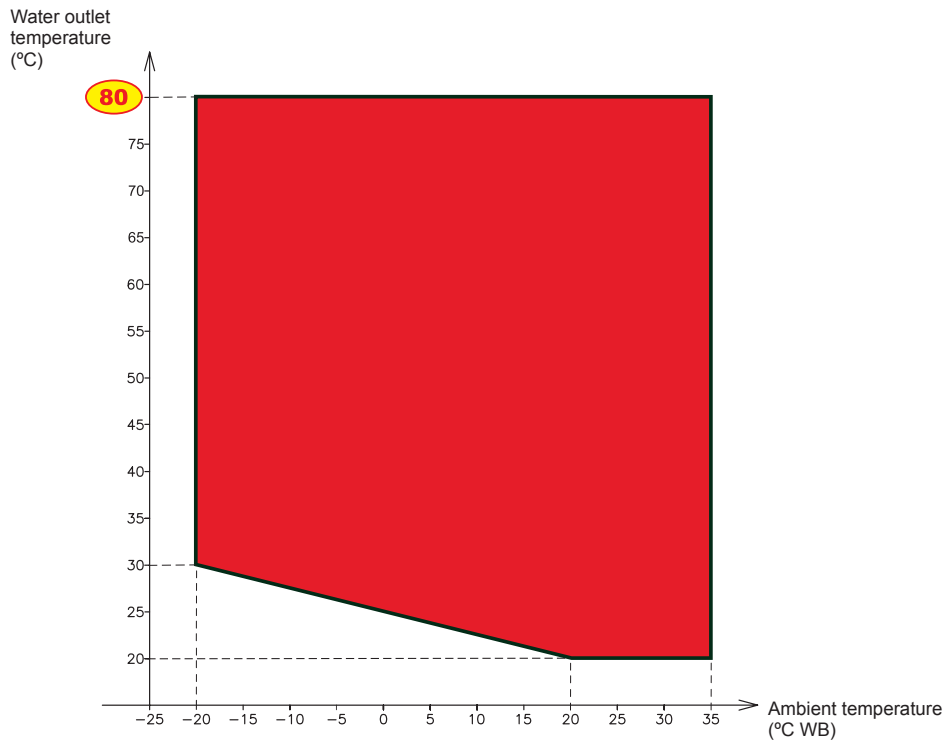

YUTAKI S80 is the best solution to replace existing boilers which work on systems with old radiators and weak isolation, or for new installations with very high capacity requirements. For new installations with low capacity requirements the best solution could be YUTAKI S unit.

By this way, HITACHI covers the main heating requirements of the market.

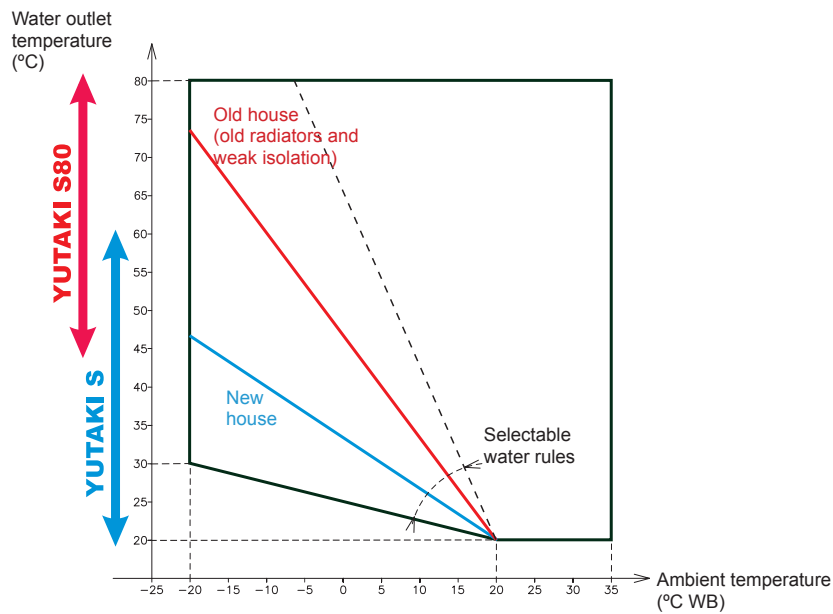



◆ **Concept of SMART cascade cycle**

The normal cascade cycle would work continuously using two single-stage cycles; the innovative YUTAKI S80 SMART cascade cycle allows to take advantage of the best possible performance depending on the water outlet temperature required.

Thereby, when the installation would require low water outlet temperatures, only one cycle will work (R410-H<sub>2</sub>O) whereas that when the installation would require high water outlet temperatures, the two cycles will be activated (R410A-R134a and R134a-H<sub>2</sub>O).

This control is possible by the actuation over the solenoid valves (SV1 and SV2). When the unit requires working with only one cycle the SV1 remains ON and SV2 OFF, whereas that when the installation requires working with the cascade cycle the SV1 pass to OFF and SV2 pass to ON.

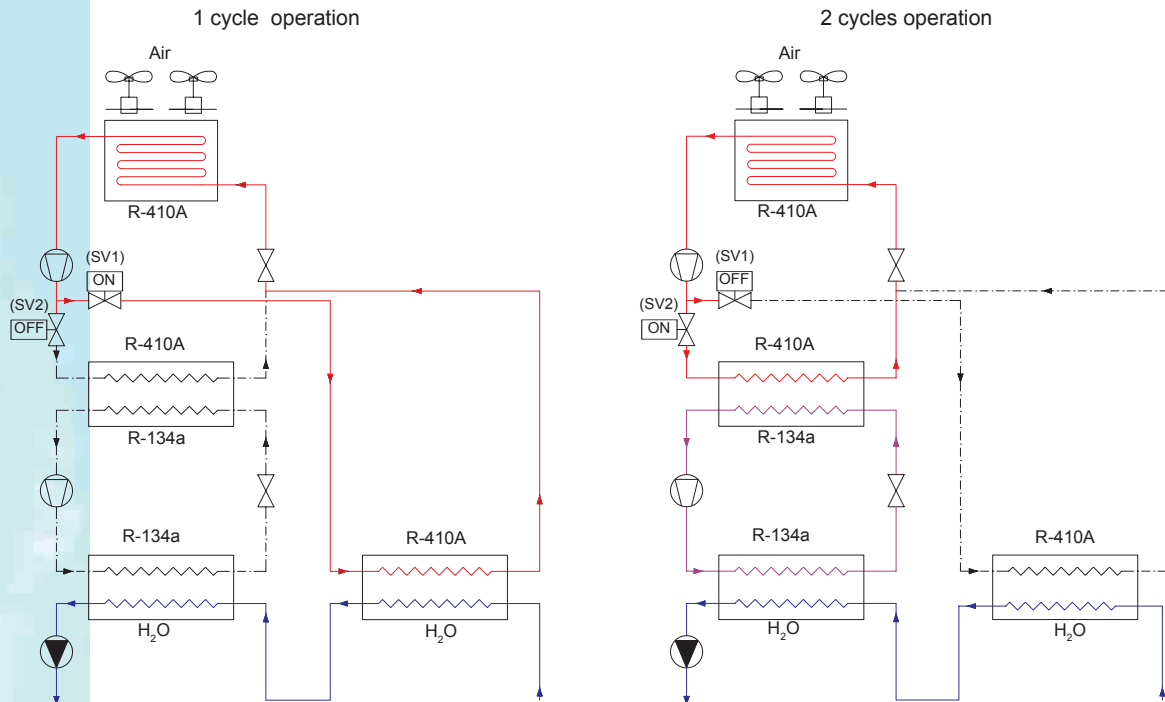

The innovative SMART cascade cycle results in a better COP than cascade conventional cycles, because it leverages the best working conditions for any moment.

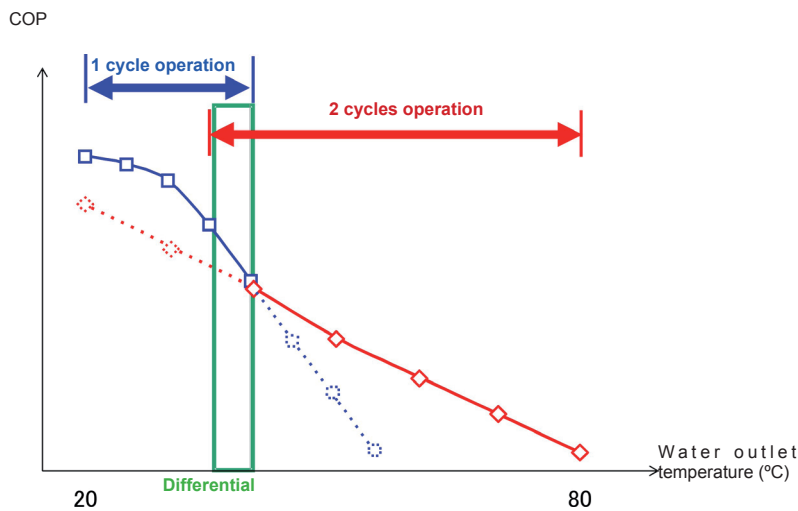



### 2.2.4 High efficiency system

The combination of the scroll compressor and the inverter type continuous control, the “smart cascade” system, the high efficiency plate heat exchangers and the water pumps classified as low energy power input allow the maximum energy efficiency, resulting in the highest coefficient of performance (COP) of the market.



**i** **NOTE**

Conditions range:

- COP: Water inlet / outlet temperature: 30/35 °C

Outdoor Temperature (DB/WB): 7/6 °C

### 2.2.5 Wide capacity range

The YUTAKI S80 system provides the highest maximum heating capacity of the market at high water outlet temperatures and for a wide range of outdoor temperatures, including very cold conditions.

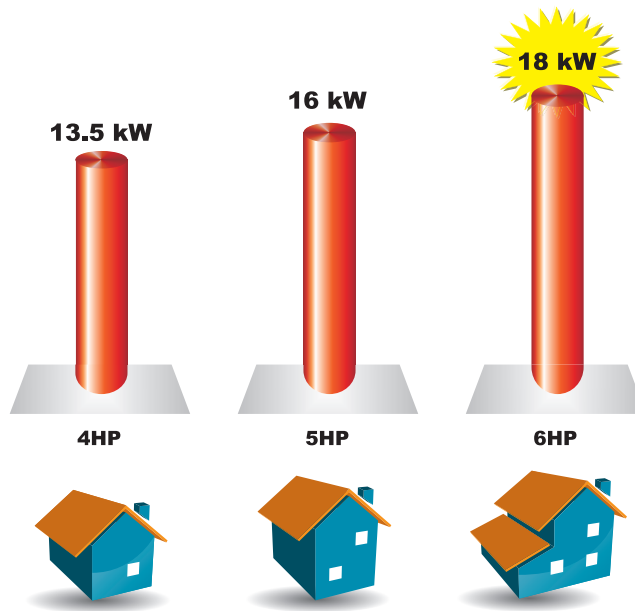

2

### 2.2.6 Nominal heating capacity stable at low outdoor ambient temperatures

The YUTAKI S80 system is able to keep the heating capacity stable at low outdoor ambient temperatures, even for high water outlet temperatures. Therefore, the use of a water electric heater or boiler is highly reduced.

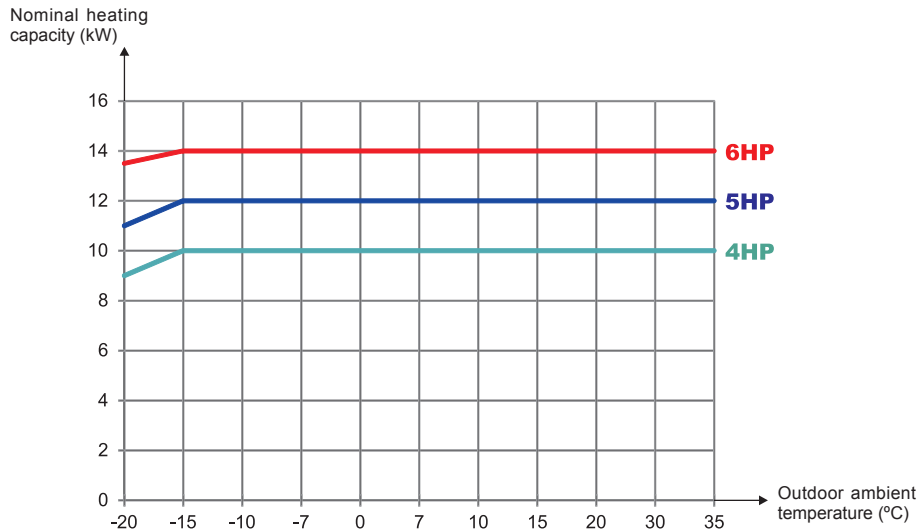

**i** NOTE:

Water inlet / outlet temperature: 55/65 °C

### 2.2.7 Adaptability to the customer's/system needs

Depending on the type of heating installation system (existing or new) and the user's needs, the most suitable system for each situation can be chosen.

There are three main heating system configurations:

- Mono-valent systems
- Mono-energy systems
- Parallel bi-valent systems (For boiler combination)

Selecting the different configuration types it is possible to adapt the system to all customer requirements, providing a wide application range from the simplest configuration to complete configuration, as shown below:

Radiator/(fan coil), heating floor or both (2nd temperature area). Also combinable with the following options:

- Domestic Hot Water (DHW)
- Use of electric heater or boiler for low ambient temperature conditions.
- Solar combination for DHW (not compatible with integrated tank over indoor unit).

### 2.2.8 Wide range of accessories

In order to enable all the possible system configurations explained previously, there are available a large set of accessories designed to adapt the unit to the type of installation which the system needs.

**i** NOTE

For knowing the different accessories that offers the system, please refer to the section [Accessory code list](#) on chapter [General information](#).

**2.2.9 Advanced technology**

The functionality benefits explained before (Highly efficiency system, wide capacity range, etc.) are direct consequence of the advanced technology applied on all the system components.

Then, the main features on different components of the system will be detailed:

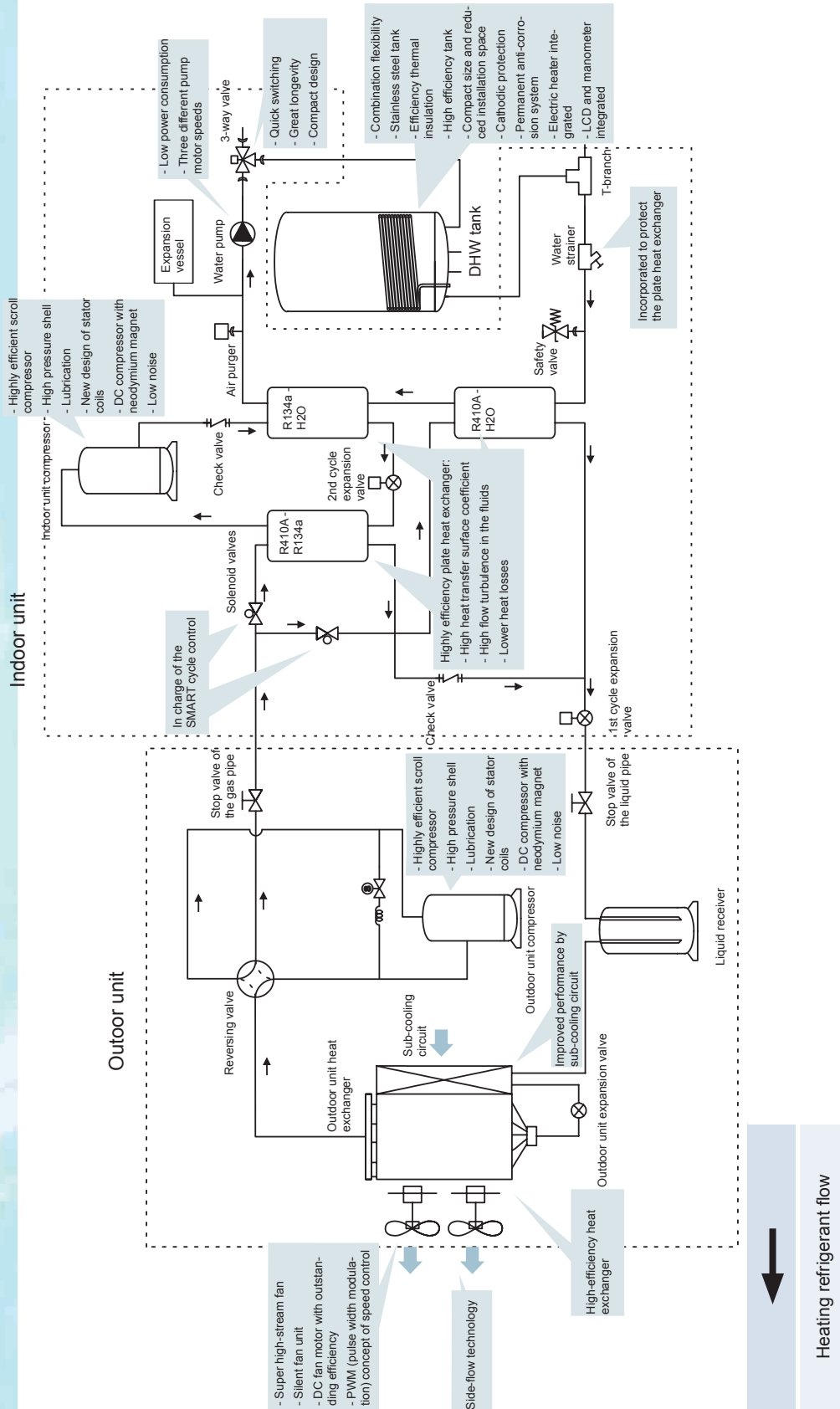

**◆ Outdoor unit heat exchanger****High-efficiency heat exchanger**

- The slitless fin design is adapted to the heat exchanger. As a result, the frosting effect is prevented by the surface of the slitless fin and the heating performance is improved under the low temperature conditions.
- Compact design and high-efficiency by arranging narrow heat exchanger tubes in 3 rows.
- Heat exchanger configuration aiming at fluid loss reduction.

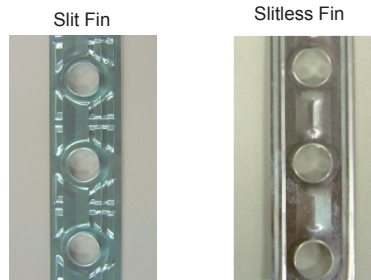
**Side flow technology**

Energy-saving and uniform air velocity distribution by side flow technology.

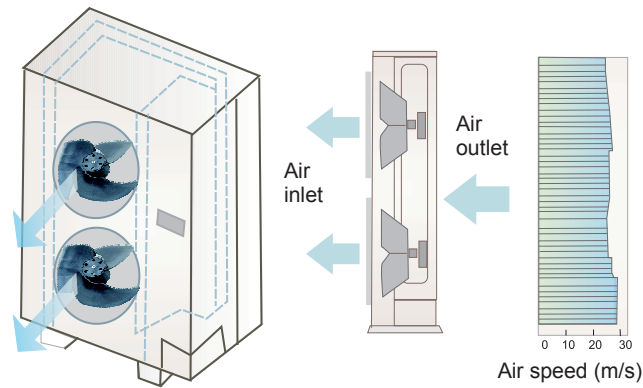

### Improved performance by subcooling circuit

The system performance is improved by enlarged heat transfer area of outdoor unit and subcooler heat exchanger.

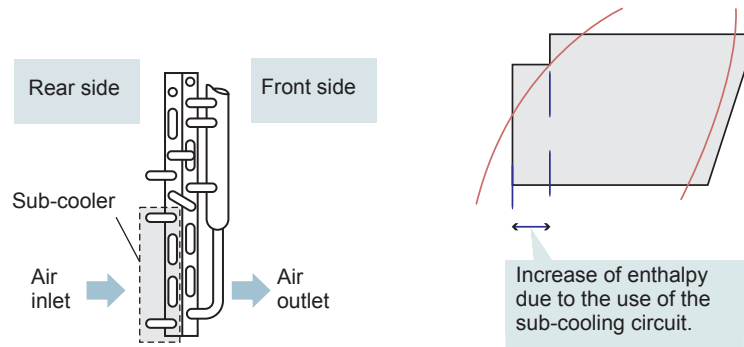

### ◆ Fan unit

#### Super high-stream fan

The outdoor units have been designed with a new super high-stream fan of  $\varnothing 544$  mm, reducing the sound level and increasing its reliability, by the use of a three-blade design propeller.

This fan is much more aerodynamic than earlier models. It has a greater surface area in contact with the air and a better turning angle, preventing turbulence and allowing the ventilator to be fitted lower.

Additionally, the rib structure synchronized with rotation flow from the fan reduces the air resistance at the air outlet grille.

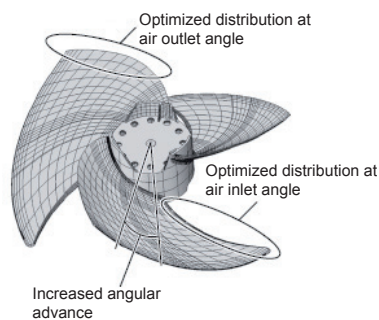

#### Silent fan unit

Low noise due to the following aspects:

- Combination of the three-blade and slim fan: The fan has been designed to have a lower body than traditional fans, and achieves surprising results, with a noise reduction of up to 4dB (A).

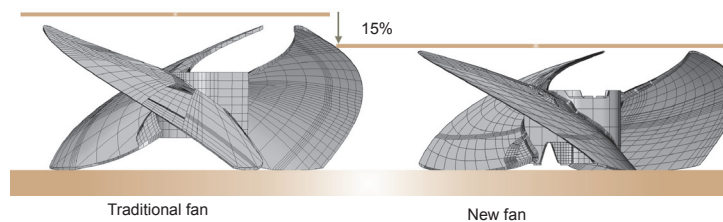

- DC fan motor: The smooth rotating fan motor with low vibration reduces the noise generation.



**DC fan motor with outstanding efficiency**

The DC fan motor greatly improves efficiency compared to conventional products with AC motors. In addition, air blasts are reduced by controlling the rotation speed of the fan. Stable operation is provided against strong head winds of approximately 10m/s on the front face of the outdoor unit.

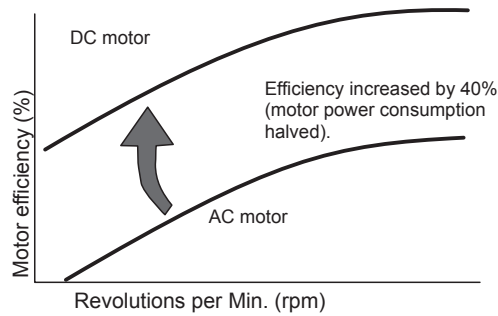

**PWM (pulse width modulation) concept of speed control**

The switching element (a power MOSFET) switches back and forth at a frequency of several tens of kHz. This controls the ON/OFF duty rate per cycle and changes the voltage applied to the fan motor to control the rotation speed.

◆ **HITACHI scroll compressors (R410A for the outdoor unit and R134a for the indoor unit)**

**Highly efficient scroll compressor**

The HITACHI DC INVERTER scroll compressor has been developed to increase efficiency, reliability and to reduce power input.

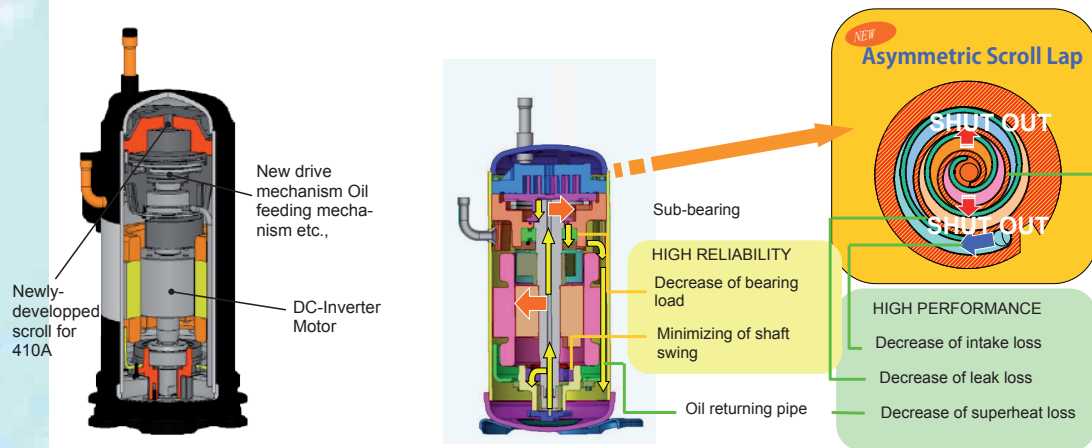

**High pressure shell**

- It acts as an oil separator reducing the amount of oil circulating in the cooling system giving better heat exchanger efficiency.
- Motor heat is not added to the suction gas before compression, which reduces the discharge gas temperature. This is particularly important at low suction temperatures. The discharge gas cools the motor sufficiently.
- Refrigerant cannot enter the shell during the off cycle causing oil dilution and oil foaming at start up.
- System of regulating pressure, increasing the compressor's efficiency and reliability in part load mode. This system ensures the work pressure of the compressor is always at optimum level regardless of the charge, so that the ratio between the discharge pressure ( $P_d$ ) and the suction pressure ( $P_s$ ) is optimum as in the following graphic:

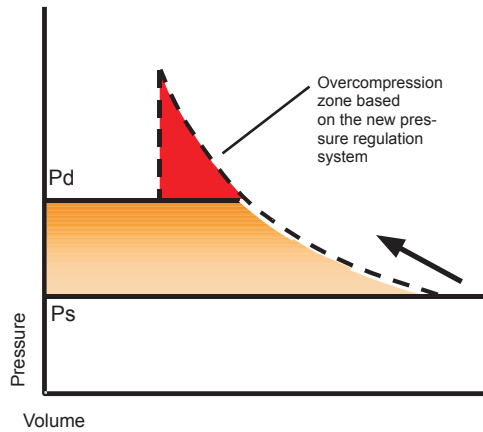

**Lubrication**

Bearing in mind that lubrication is one of the most important factors in the service life of a compressor, HITACHI has developed a system based on the pressure differences between the suction and discharge using a secondary pump at the base of the compressor. As a result, all of the compressor's moving parts are lubricated evenly, ensuring high reliability in terms of its operating range, even at low frequencies.

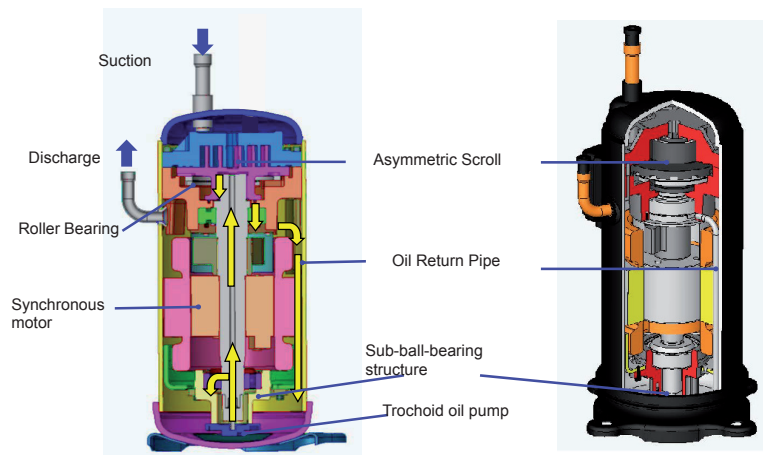

2

**Protection against liquid return**

When the compressor is at rest, the moving scroll rests on the casing. When the compressor starts to run, the pressure in the chamber under the scroll builds up through two bleed holes in the medium pressure section of the compression stroke. This pressure then forces the scroll up against the housing and seals the compression chamber. If liquid returns to the compressor, the resulting increase in pressure forces the scroll downwards, breaking the seal and allowing the liquid to pass back into the compressor body, where it will boil off due to the higher temperature.

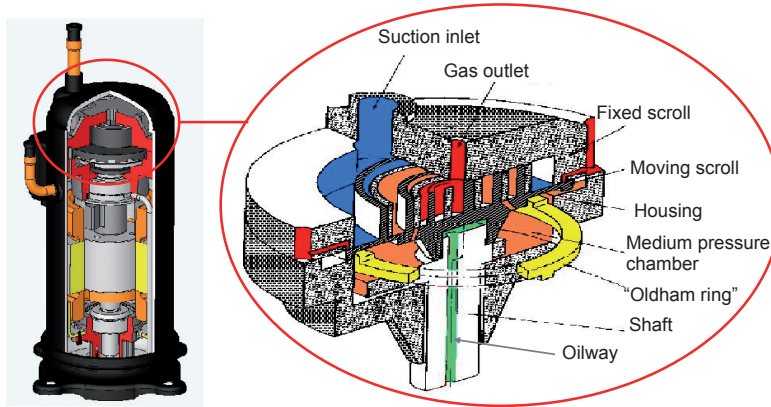

**Optimized design of stator coils**

The design of the stator coils positioned to optimize the magnetic field significantly reduce heat losses, and increase the motor's efficiency at low speeds.

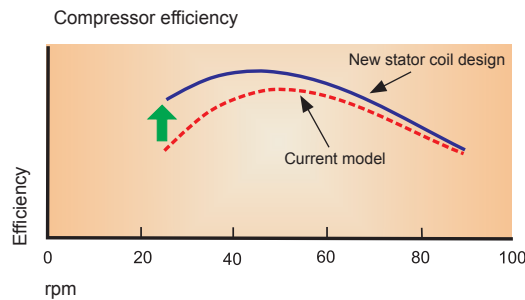

**DC compressor with neodymium magnet**

The use of a DC compressor with neodymium magnets in the rotor improves the performance at around the 30-40Hz range where the operation time of the inverter compressor is longest. Additionally, to suppress electromagnetic noise interference and achieve low noise, the rotor has been divided into two parts and the electric pole displaced.

Characteristics at low speed, which affect the annual running cost, have been significantly improved.

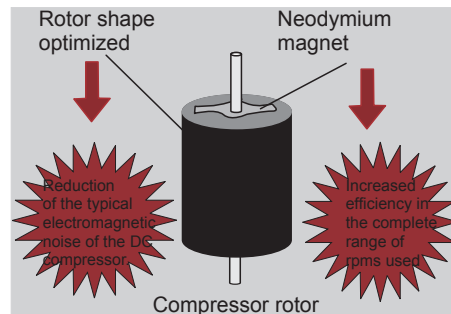
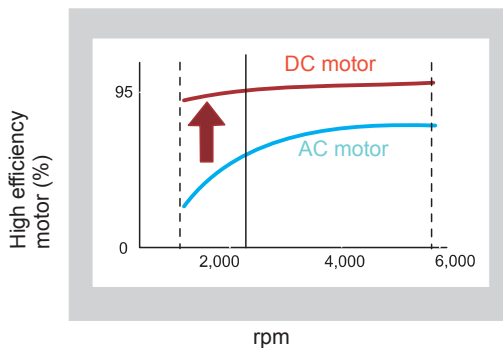



**Low noise**

- Inverter control: The inverter controls compressor speeds from 30Hz to 115Hz, quickly reaching the set temperature and maintaining a stable energy-saving operation, thus reducing the noise since the compressor is not running continuously.

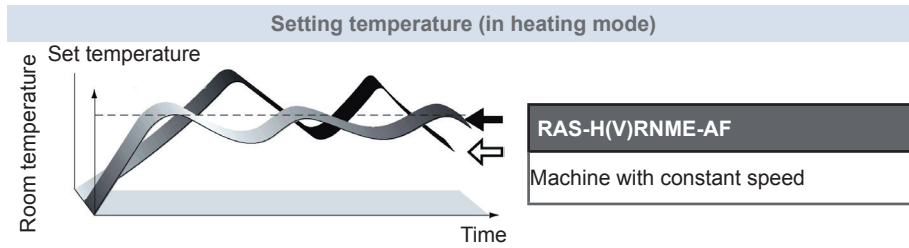

- In the case of RAS-H(V)RNME-AF: Quickly reaches the temperature set at high power, then maintains stable energy-saving operation.
- In the case of other constant speed machines: Slowly reaches the set temperature, then turns on and off repeatedly to maintain the temperature, operating uneconomically and wasting energy.

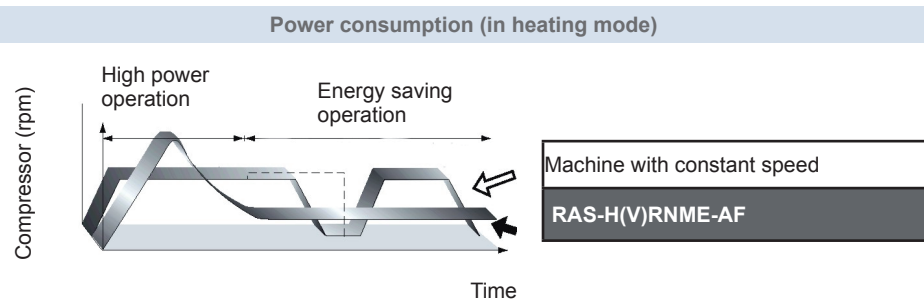

- In case of existing machines with constant speed, repeated turning on and off wastes energy.
- Optimized rotor shape: The scroll compressor allows reduced noise and vibration levels due to:

- The compression points are evenly distributed along the compression stroke.
- The reduced number of components used
- Use of a high-pressure insulation shell.

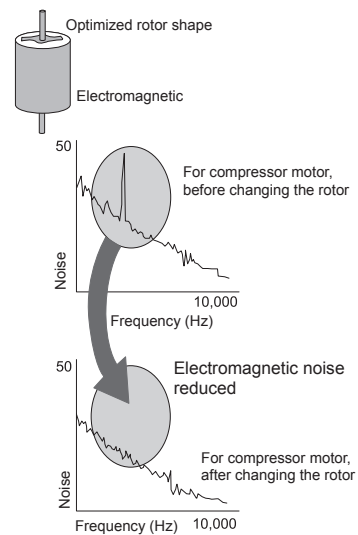

- Acoustically insulated compressor: The scroll compressor is insulated by means of a acoustic cover, providing minimum noise levels.



2

**◆ Indoor unit heat exchanger (For R410A and R134a)**

The indoor unit has three heat exchangers:

- R410A-R134a plate heat exchanger
- R410A-H<sub>2</sub>O plate heat exchanger
- R134a-H<sub>2</sub>O plate heat exchanger

**Highly efficiency plate heat exchanger**

The use of a plate heat exchanger type allows getting high performance due to the following advantages:

- High heat transfer surface coefficient, leading to very high values of the heat transfer overall coefficient.
- High flow turbulence in the fluids, achieving turbulent regimes for low Reynolds numbers. This high turbulence allows lower circulating speeds on the fluids.
- Lower heat losses, since only the edges of the plates are exposed to the outside environment and additionally to having small thicknesses, it can be readily isolated.

**◆ Water pump****Low power consumption**

The air to water heat pump incorporates a water pump to circulate the water flow into the system.

This pump is classified as low power consumption, resulting in a higher unit performance.

Water pump

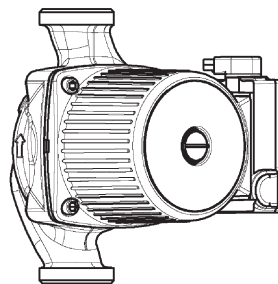

### Three different pump motor speeds

In order to adapt the flow rate to the system requirements, there are available three pump motor speeds.

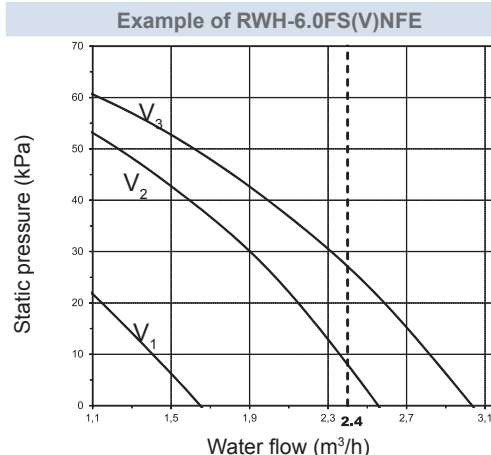
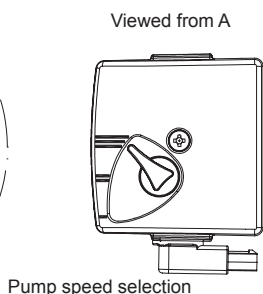
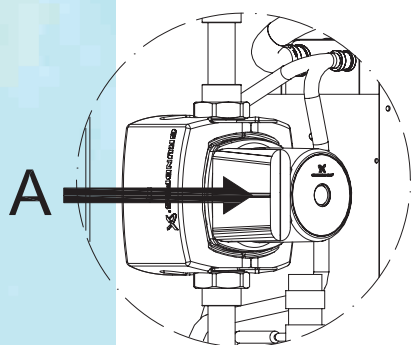

#### **i** NOTE

**V:** Pump motor speed (V<sub>1</sub>: Low, V<sub>2</sub>: Medium, V<sub>3</sub>: High)

#### ◆ 3-way valve



#### Quick switching

The fast change-over in diverting applications reduces unnecessary energy consumption. This valve is extremely fast: it change from A to B circuit taking only 3 seconds.

The job of the diverting valve is to divert hot water between the space heating and DHW production. Optimal heat production is achieved through well-functioning cooperation between the diverting valve and the heat pump.

#### Great longevity

In order to reduce friction the valve housing is made of brass and has a Teflon-blended composite regulating cone, sealing against specially prepared O-rings.

The actuator's basic design is uncomplicated with its integrated transmission. A micro processor based circuit board is located under the cover and it among other things has an integrated anti-jamming program, which makes sure that at least every 7th day a complete change-over cycle is made to prevent the regulating cone from jamming.

Other life-shortening hazards by developing a secure lid solution, 0-percentage internal leakage and corrosion protection have been eliminated.

#### Compact design

This valve is easy to use, easy to control and easy to understand.

The actuator can easily be removed by just pushing the release button. Pushing the release-button once more allows it to be re-attached - let go of the button, and the actuator is mounted.

At occasions when the heat pump for some reason shuts off or is not fully operational, an even flow may still be maintained in both circuits by quite simply removing the actuator. The diverting valve will then automatically position itself so that flow is allowed in both circuits simultaneously.

**◆ Domestic hot water tank (optional accessory)**

The domestic hot water tank is an accessory supplied by HITACHI which allows the domestic hot water production, with the following characteristics:

DHWS195S-2.0H1E



DHWS260S-2.0H1E

**Combination flexibility**

There exist the possibility to install the tank integrated over the indoor unit or beside it.

**Stainless steel tank**

Tank models are made in Stainless steel chemically descaled and passivated.

**Efficiency thermal insulation**

Thermally insulated with rigid, mould-injected, in Neopor EPS in grey color.

**High efficiency tank**

Optimum design of the heat exchanger coil to provide the maximum domestic hot water production capacity to the system.

**Compact size and reduced installation space**

Elimination of cold zones at the bottom of the storage tank to prevent the risk of bacteria proliferation (e.g. legionella).

**Anodic protection**

Anodic protection installed with 200g aluminium anode (which it not has to be replaced) and load measured on the front panel.

**Electric heater integrated**

Standard factory supplied 2.0kW immersion electric heater element fitted into the side sealed gasket.

**LCD and manometer integrated**

LCD and manometer are easily accessible from the front side of tank, protected by the LCD user's interface cover.

## 2.3 Installation benefits

### 2.3.1 Different possible installation types

YUTAKI S80 unit is a floor standing structure which provide several different possibilities of installation configurations:

A) Indoor unit alone  
(Without tank)

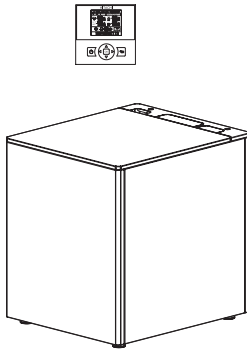

B) Indoor unit with HITACHI tank  
(Tank integrated over the indoor unit)

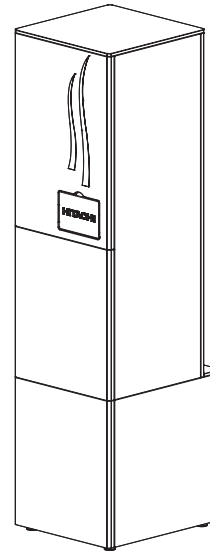

C) Indoor unit with HITACHI tank  
(Tank beside the indoor unit)

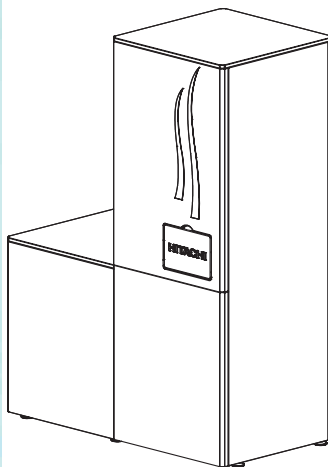

D) Indoor unit with other tank  
(Non HITACHI tank beside the indoor unit)



Depending on the configuration type, the installation procedure will be different.

### 2.3.2 Easy unit installation

Easier unit installation due to the following aspects:

#### ◆ Compact size

- Reduced unit dimensions:
  - Both indoor unit and DHW tank models are 595 mm of width, very suitable for indoor utility room (<600 mm).
  - Indoor unit with integrated tank DHWS195S-2.0H1E is lower than 2m of height.
- Steel plate cover: The material used for the service cover improves its rigidity.
- Hidden LCD user's interface (for domestic hot water tank): The LCD user's interface is hidden and protected by its service cover.

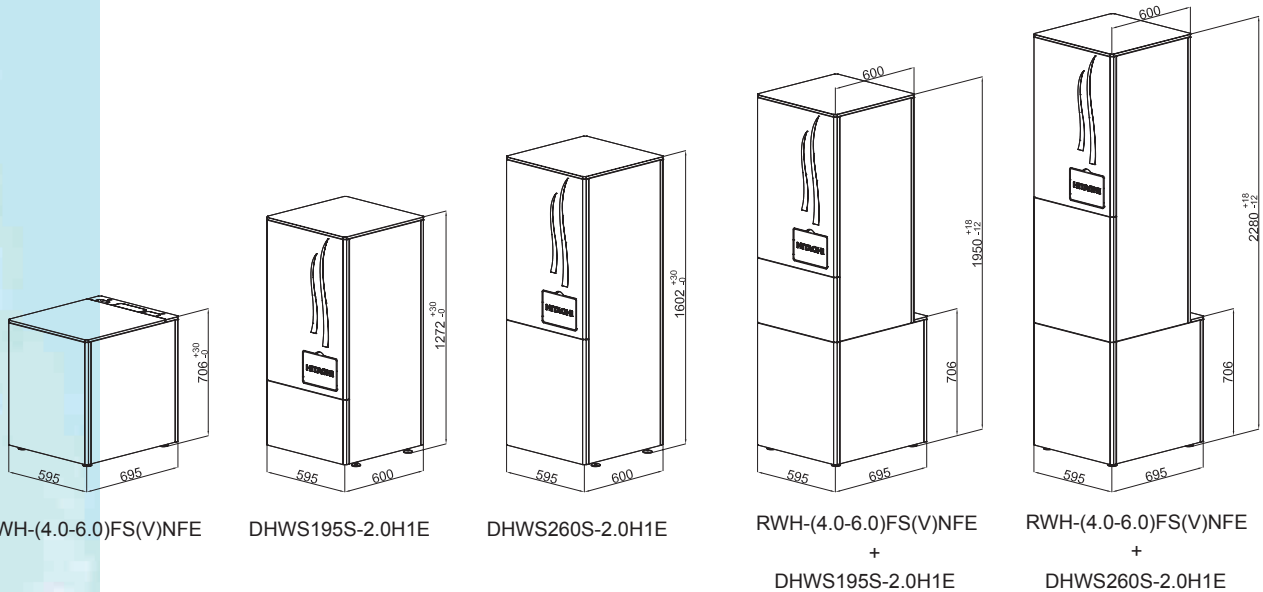

#### **i** NOTE

*Height dimensions are shown with the minimum mounting foot height. These values can be adjusted up to +30 mm.*

#### ◆ Many piping outlet possibilities

Refrigerant piping and flexible water piping outlet can be done both vertical and horizontal outlet. It will depend on the decided installation type.

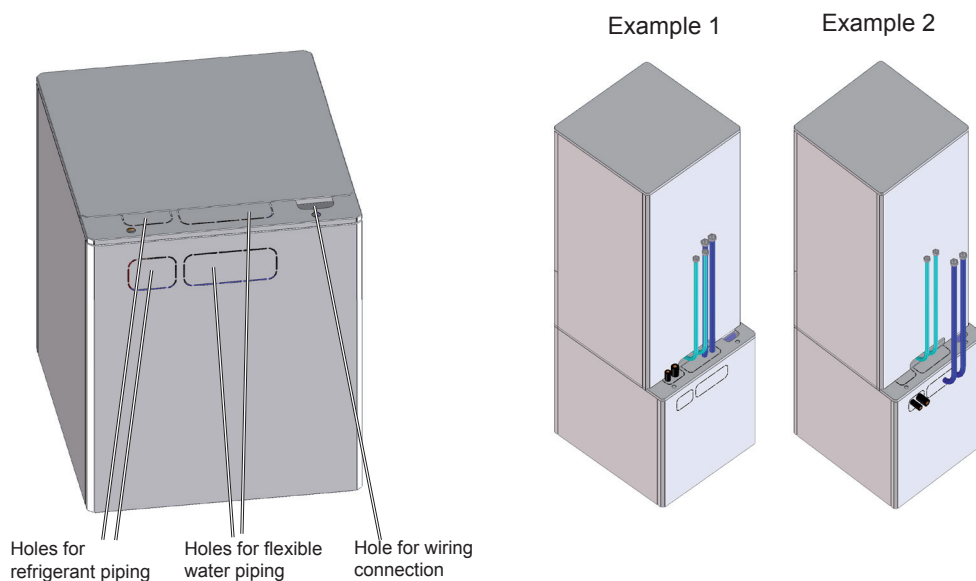

◆ **Flexible water piping**

The water piping are flexible in order to make easy the installation work.

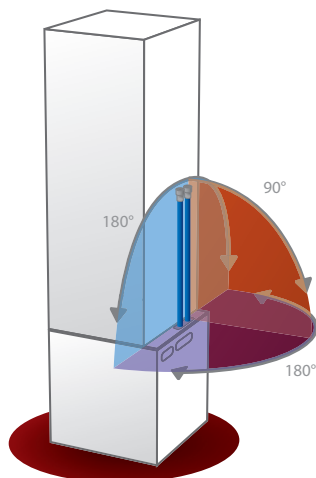

**2.3.3 Easy and flexible electrical installation**

◆ **Easy wiring**

It has been designed a big terminal board (TB2) in order to allow the easy electrical connection which provide all the different possible configurations (3-way valve, water pumps, boiler...).

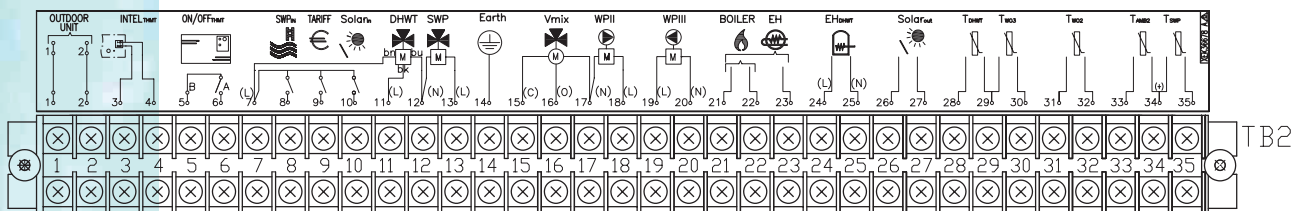

Additionally, in order to help with the electrical installation works, HITACHI offers the following specific documentation:

- Service Manual and Installation and Operation Manual: All the necessary information about how to perform the electrical works (electrical installation, connection, dip switch setting, ...) is reflected in these documents.
- Schematic label: The different possible connections to the terminal boards are indicated by means of a schematic label with the figure corresponding at the required configuration (see previous figure).
- Big Electrical Wiring Diagram and Caution Label: There are two labels stuck on the rear side of the electrical box cover for a quick referring when electrical works are required. So, installer can get easy and clear wiring understanding and LCD user's interface icons/alarms by directly referring to these labels.
- Separated terminal boards. The TB1 is the power connection board, and the TB2 is the accessories connection board, with an additional ground socket (position 14).

**i NOTE**

*These points can be also understood as Maintenance benefits.*

## 2.4 Start-up benefits

### 2.4.1 Start-up by pressing the Run/Stop button of LCD user's interface

The unit is factory set to work only by pressing the Run/Stop button of the LCD user's interface.

The default value is set for one circuit (Direct) with OTC gradient for heating space of 1.4, corresponding to a high temperature system (for example, radiators).

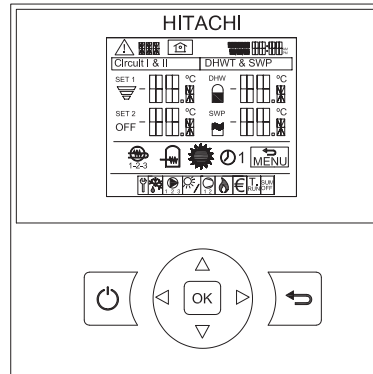

### 2.4.2 Floor screed drying (Circuits 1 & 2) (Optional function)

The new air to water heat pump has a special optional function used exclusively for the process of drying of newly applied screed on floor heating system. This process is based on EN-1264 part 4.

When the user activates the floor screed drying function, the water set point follows a predetermined schedule:

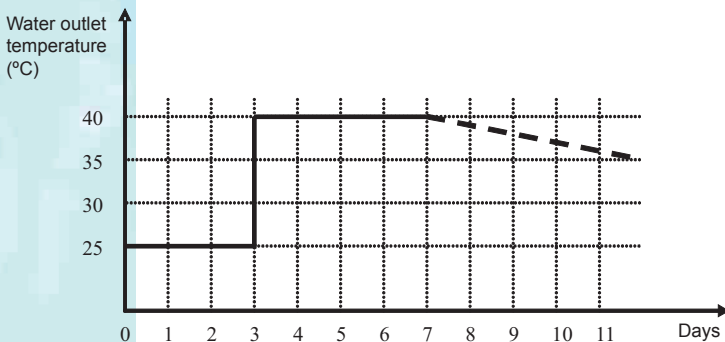

- 1 Water set-point is kept constant at 25°C for 3 days.
- 2 Water set-point is set to the maximum heating supply temperature (but always limited to  $\leq 55^\circ\text{C}$ ) for 4 days.
- 3 After 7 days started the floor screed drying, the water outlet temperature will return at the assigned water temperature setting, depending on the water rule selected.

### 2.4.3 Test run operation from LCD user's interface

In addition to the usual test run by outdoor unit, there is available a test run function from the LCD user's interface of the indoor unit to check the system performance.

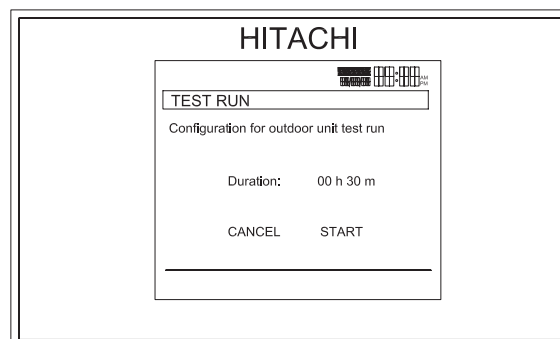

#### **i** NOTE

For more information, please refer to YUTAKI S80 indoor unit Installation and operation manual.



## 2.5 Control features

### 2.5.1 Easy to use - New LCD user's interface (PC-S80TE)

A user-friendly interface control has been designed to supply as accessory for indoor unit alone (without tank) and integrated into the DHW tank for indoor unit with HITACHI tank (Tank integrated over the indoor unit). This controller allows the remote control of the air to water heat pump by using the "Intelligent" Thermostat (as accessory).

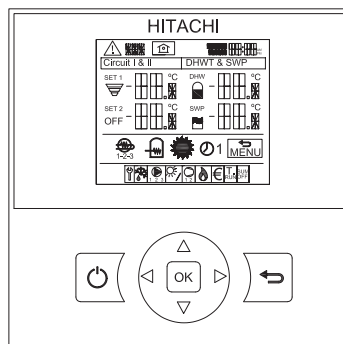

The design of the new user's interface has the following features:

#### ◆ Few number of buttons

The working mode is very simple, with only 7 buttons that make possible to access to all the display menus.

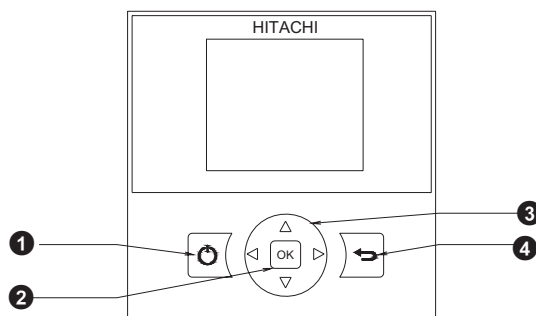

Buttons description:

- **1** RUN/STOP unit: Pressing this button, it will be switched ON/OFF the selected zone, or all the unit if there is no zone selected.
- **2** OK: Used to select items and confirm the edition of them.
- **3** 4 Arrows: For moving inside the menus and views.
- **4** Return: Used as a cancel button when editing an item or for going back to the main menu from the global view.

#### ◆ Easy unit configuration

The LCD user's interface configuration allows the setting of all the values of the air to water heat pump, which are available for the installer.

It is possible the configuration of the following modes:

- Space heating
- DHW
- Swimming pool
- Historical data
- Synchronizing time with solar DHW system.
- Optional functions
- Etc.

#### **i** NOTE

**For more information, please refer to YUTAKI S80 indoor unit Installation and operation manual.**

### ◆ Complete display menu (Comprehensive view)

Main screen is called “comprehensive view”. It provides the general system information distributed in 4 zones (Circuit I, Circuit II, Domestic Hot Water and swimming pool) through the screen, separating the different working concepts allowing checking the status of each circuit.

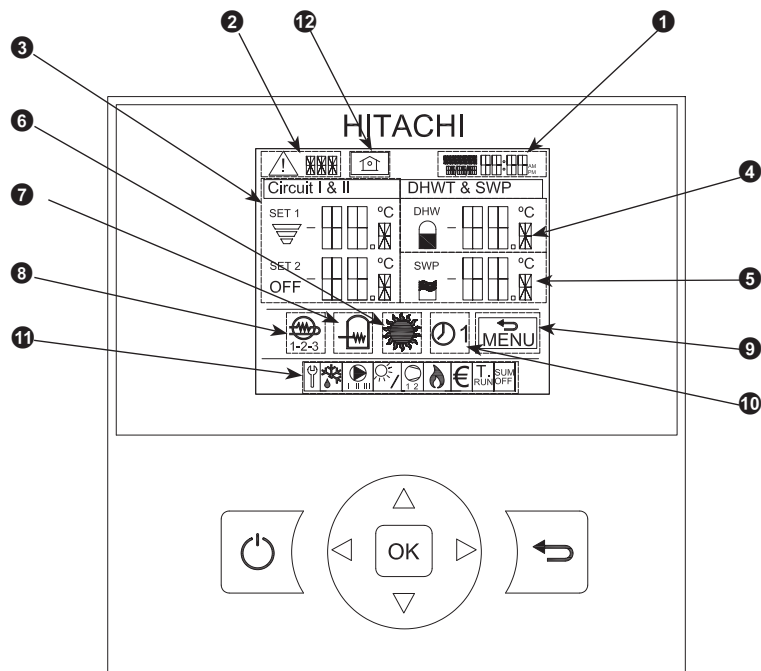

- |                                |                           |   |
|--------------------------------|---------------------------|---|
| - ❶ Time and date              | - ❺ Swimming pool control | - ❾ Configuration menu                  |
| - ❷ Alarm indication           | - ❻ Unit mode (Heating)   | - ❿ Timer indication                    |
| - ❸ Control of circuits I & II | - ❼ DHW heater operation  | - ❶⓪ Unit status signals                |
| - ❹ DHW control                | - ❽ Heater steps          | - ❶❶ Unit mode local/central <b>NEW</b> |

### ◆ Two configuration modes

- User mode: This mode allows to the user the setting of some parameters and the selection of some options of the LCD user's interface.
- Installer mode: High privilege mode for setting other configuration parameters available only for the installer. To work in installer mode, it is necessary to enter a specific password. If the correct access code is entered, it will appear the installer mode icon on the notifications row (bottom line of LCD user's interface).

## 2.6 Control features

### 2.6.1 Flexible space heating configuration and control

#### ◆ Many available system configurations

As mentioned before, YUTAKI S80 allows the control of a large variety of configurations.

#### **i** NOTE

*For the detailed information, please refer to the section “Installation configurations”.*

#### ◆ Second water temperature control

YUTAKI S80 allows the water temperature control of two zones with different required temperatures (radiators + heating floor for example) by means of the 2nd Temperature Room Thermostat (as accessory).

The mixing valve is controlled to maintain the second supply temperature at the second temperature set-point. The system control then decides how much to open or close the mixing valve to achieve the desired position for the valve.

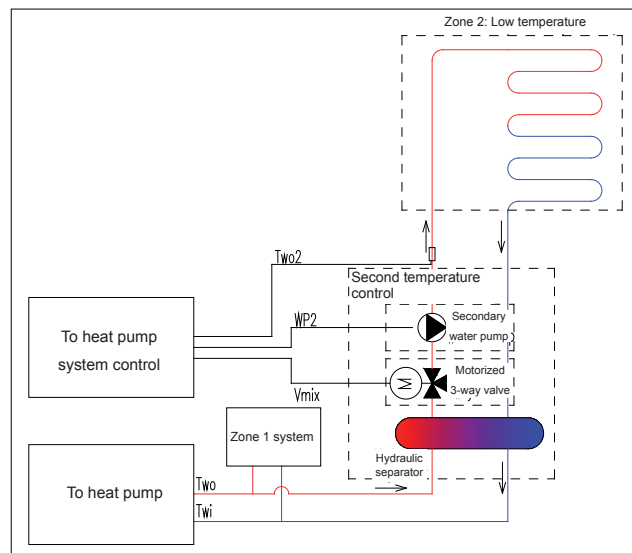

#### **i** NOTE

*High temperature must be the direct circuit and low temperature must be the second circuit.*

2

◆ **Three different possible water temperature set-point configuration modes for each zone**

- OTC Points: Water target is selected by an Outside Temperature Compensated (OTC) control that is defined by 4 different points (Minimum and maximum water outlet temperature vs Minimum and maximum outdoor ambient temperature).

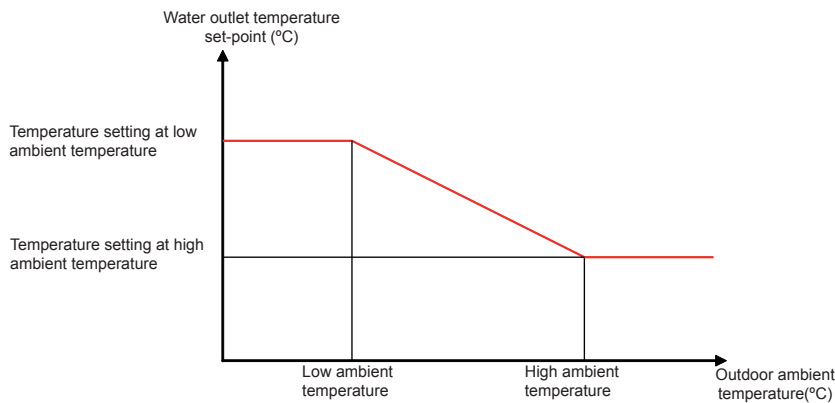

- OTC Gradient (Only for heating space): Water target is selected by an Outside Temperature Compensated (OTC) control that is defined by a different gradient of the curve. The initial point of the curve is always 20°C-20°C (Water outlet target 20°C at outdoor ambient temperature of 20°C).

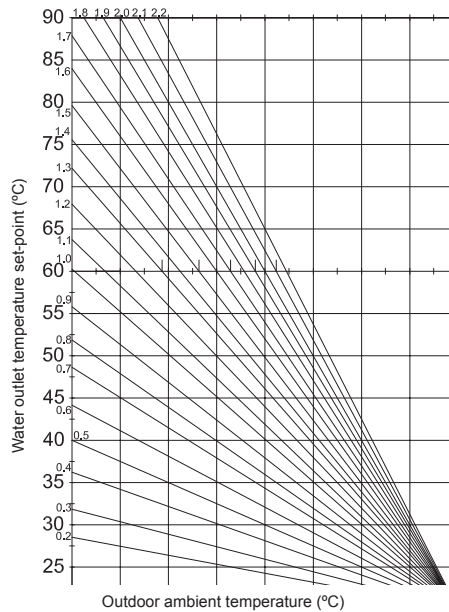

- Fixed temperature: Water target value is defined by a fixed temperature set by the user.

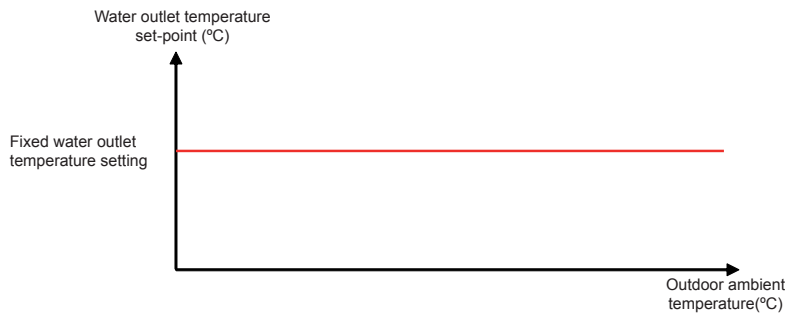

### ◆ Maximum/minimum water temperature setting for space heating protection by Installer mode

- Heating circuit minimum/maximum temperature limits selection by installer: The installer will limit the space heating temperature set-point in order to prevent excessively high or low temperatures.

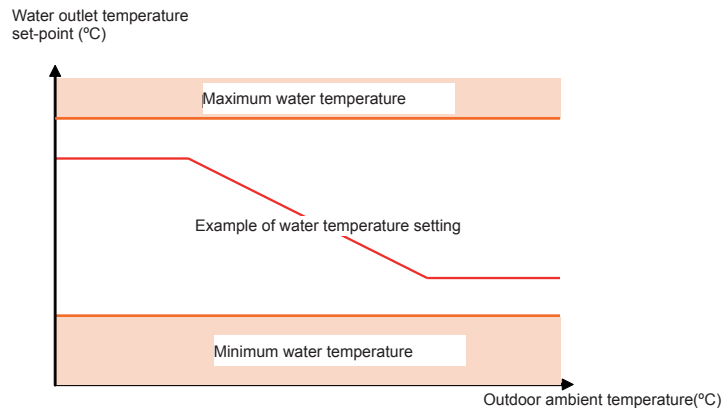

### **i** NOTE

- *Very useful when water calculation type selected is by gradient*
- *Temperature limits have priority against all other temperature set point modifications, and minimum/maximum water temperature is limited by air to water heat pump's working range.*

### ◆ Room thermostat units

There are available two types of room thermostat units:

- ON/OFF room thermostat unit (accessory): When the room temperature setting is higher than the room actual temperature, it is provided a thermo-ON signal to the system. Once reached the room temperature setting, it will be provided a thermo-OFF signal to the system.



- Intelligent room thermostat unit (accessory) with extension room thermostat (accessory) for the second circuit: Based on Outside Temperature Compensation (OTC). Water outlet target temperature is automatically recalculated taking into account the outdoor ambient temperature and the difference between the room setting temperature and the room actual temperature.



◆ **Complementary heating**

**Electric heater (as accessory)**

For the most low ambient temperature conditions the electric heater will be enabled in order to provide the necessary supplementary heating, but only when the unit is operating in space heating mode.

- 3 steps heater control: The desired heating supplied by heater is determined by the Load factor, which is calculated by a P+I function ranging from 0 to 100%. Actual heater output will be translated from percentage to a 3 step output using hysteresis system.

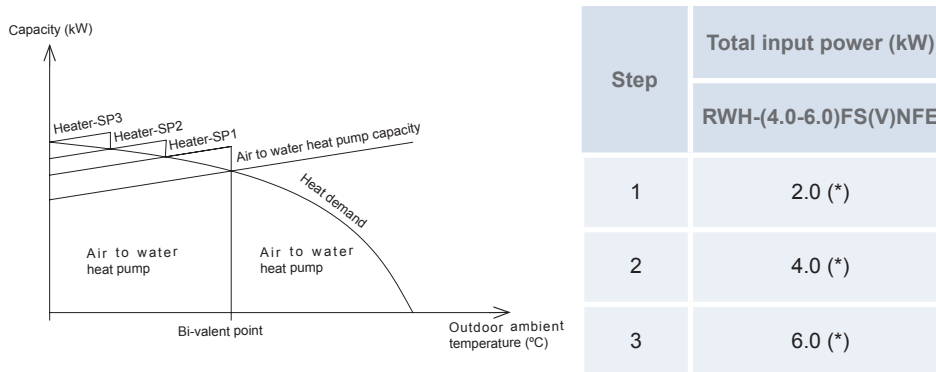

**i NOTE**

(\*): The input power values shown previously are explained as example for water electric heater supplied for HITACHI as accessory (WEH-6E), with a total input power of 6.0 kW. For water electric heaters of other total input power, the input power for each step will be different.

- Electric heater for emergency mode (Optional function): In case of outdoor unit malfunction, the required heating can be provided by the electric heater.
- One step heater for 3 phases unbalance (Optional function): For 3 phases units, in order to prevent 3 phases unbalance of the installation by electric heater steps, this option will be used to switch the 3 steps at the same time.

**Boiler combination**

When the unit is not able to provide the necessary heating capacity in low ambient temperature conditions, it will be stopped and the boiler starts to operate providing the necessary heating capacity. The unit should be sized in order to operate mainly with the air to water heat pump, and boiler will be only activated in low ambient temperature conditions.

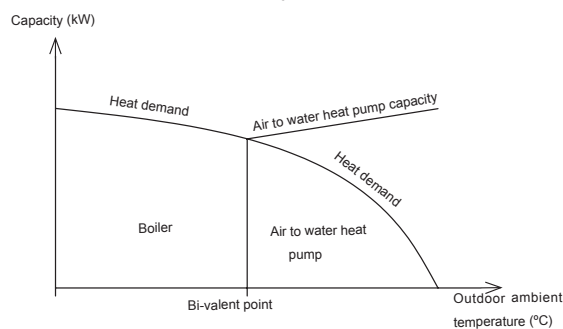

- Boiler for emergency mode (Optional function): In case of outdoor unit malfunction, the heating required can be provided by the boiler.

### 2.6.2 Flexible Domestic Hot Water (DHW) control

An optional Domestic Hot Water Tank (DHWT) accessory can be connected to the air to water heat pump in order to provide the Domestic Hot Water operation. The DHWT is available in 2 models stainless steel, with an integrated electric heater of 2.0 kW.

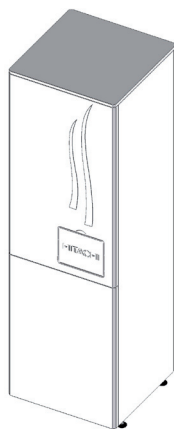

#### **i** NOTE

For more details, please refer to the Domestic hot water tank Installation and Operation manual.

#### ◆ Domestic hot water emergency operation

In case of outdoor unit or indoor unit malfunction, the domestic hot water tank can be heated by an internal domestic hot water tank heater activating an specific switch placed beside indoor unit manometer. In this case, the temperature setting is performed by the heater's thermostat.

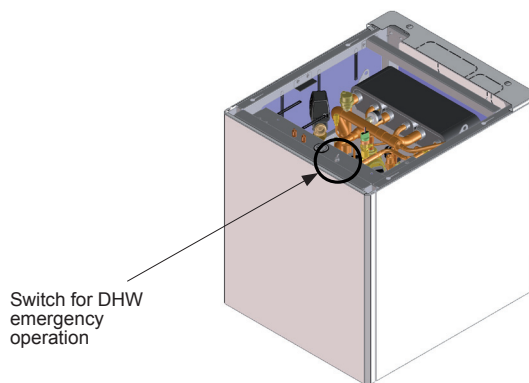

#### **i** NOTE

Refer to the Electrical data for the details of CB and ELB.

#### ◆ Space heating priority mode

The Domestic Hot Water (DHW) operation has priority over all other operation modes unless otherwise noted.

It should be taken into account the following consideration:

- When DHW requires the heat pump operation, no other modes can require heat pump operation.

### ◆ Anti-Legionella protection (Optional function)

In order to prevent against Legionella into the DHW system, it is available a specific setting which will raise up the DHW periodically over the normal DHW tank temperature setting.

The following parameters should be configured for the Anti-Legionella function:

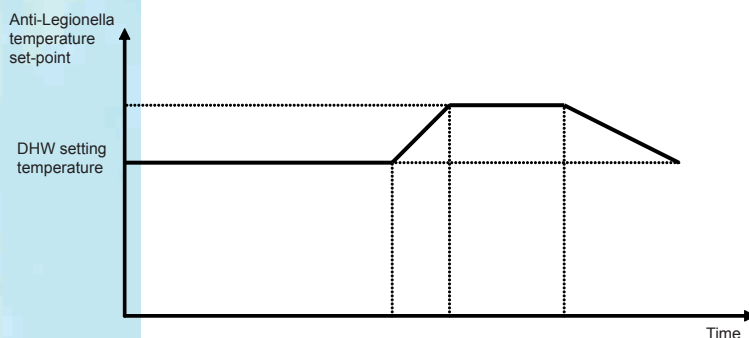

- Operation interval: Day(s) of the week at which the domestic water should be heated.
- Status: Defines whether the disinfection function is turned ON or OFF.
- Start time: Time of the day at which the DHW should be heated.
- Anti-Legionella temperature: High water temperature to be reached.
- Interval: Time period during the Anti-Legionella temperature remains constant.

### **i** NOTE

*For more details about the Anti-Legionella optional function protection, please refer to the Service Manual.*

### ◆ Maximum water set-point by the installer

The installer can set a maximum water tank temperature in order to avoid excessively hot water in the DHW tank.

### ◆ Two different modes for DHW

The DHW operation will be performed by two different modes:

- Standard mode: The DHWT will start heating when the water tank temperature is low enough for heat pump to be started. In this mode, the DHW is always heated by the heat pump.
- High demand mode: The DHWT will start heating if the difference between the maximum water set point temperature and the actual DHW temperature is bigger than a predetermined value. Only the water tank electric heater will start heating unless DHW temperature goes below the heat pump starting temperature.

### ◆ Unit timer NEW

Unit timer is provided in the unit (by the LCD user's interface) for heating space, for the DHW and for the swimming pool in order to enable/disable the operation depending on the day or the time slot. It can be programmed each day of the week.

### **i** NOTE

*For more information, please refer to the Service Manual.*

### ◆ Combinability with solar panel

As it has been explained in section [Selection benefits](#), the air to water heat pump can be combined with solar panel. The solar combination will enable to heat up the DHW by means of the sun. The solar combination is designed to transfer the heat from the solar panels (sun radiation) to the heat exchanger of DHW tank.

### **i** NOTE

*Not available when the HITACHI domestic hot water tank is integrated over the indoor unit.*



### 2.6.3 Swimming pool combination control

When the swimming pool operation is required, the swimming pool pump starts to operate giving the swimming pool pump feedback. In this situation, the 3-way valve of the DHWT is not activated and the 3-way valve for the swimming pool changes its normal position diverting to the swimming pool heat exchanger, allowing to heat the swimming pool water to a comfortable value.

The swimming pool operation has the lowest priority of the system and only will be possible when space heating and DHWT are not required.

### 2.6.4 Flexible water pumps control

#### ◆ Two different water pump modes

The pump control can be set to standard or economic mode.

- Standard mode: Pump will always be in operation when space heating is enabled, but when space heating is disabled using LCD user's interface or Thermostat OFF (intelligent thermostat only), pump must be switched OFF and only will be switched ON by DHW heating request.
- Economic mode: When the system has reached the required temperature, or the system is stopped, the water pump will be stopped (using the thermostat; no other operation is required).

#### ◆ Pump and motorized valve seizure protection (Optional function)

This function helps to prevent these components from sticking during long periods of inactivity by running every week the components during a short period.

### 2.6.5 Other optional functions

#### ◆ 2nd. outdoor temperature sensor (Accessory) (Improved for YUTAKI S80)

In the cases where the outdoor unit is installed into a location where its own outdoor ambient temperature sensor can not give a suitable temperature measurement to the system, it is available the 2nd outdoor ambient temperature sensor as accessory.

So, the 2nd outdoor ambient temperature sensor shall be located in a proper place for getting most representative outdoor ambient temperature.

**NEW**

By means of DSW setting, it can be selected the preferable sensor for each circuit. The possibilities are:

- Auxiliary sensor instead of outdoor unit sensor for both circuits.
- Outdoor unit sensor for circuit 1; Auxiliary sensor for circuit 2.
- Auxiliary sensor for circuit 1; Outdoor unit sensor for circuit 2.

#### **i** NOTE

***For more information, please refer to DSW setting section on Service Manual.***

#### ◆ Tariff switch input

This function allows an external tariff switch device to switch OFF the heat pump during peak electricity demand period. Depending on the setting, the heat pump or DHWT will be blocked when signal is open/closed.

Additionally, it's possible to set that the boiler will be enabled instead heat pump when this mode is ON.

**◆ KNX combination** 

New KNX is an interface that makes compatible YUTAKI S80 with KNX systems permitting the remote control and data viewing of the YUTAKI S80.

KNX systems are domotic networks for the centralized management of home items like lights, doors, fire systems, blinds, thermostats and others.

YUTAKI S80 is managed from KNX system as a Heating item so it can be integrated in any KNX system.

KNX system can be managed remotely from Internet.

**◆ Automatic summer switch-OFF**

The system will switch OFF the heating mode when the daily average outdoor temperature of the previous day rises above certain value at the summer switch-OFF activation temperature.

**◆ Available four external outputs signals for optional functions**

There are available four output optional signals that provide four optional functions of the system, programmed on the indoor unit PCB.

** NOTE**

- *In order to make easy the electrical connection works, HITACHI offers (as accessory) a relay board for the additional output signals.*
- *For more information about the Optional functions, please refer to the YUTAKI S80 Service Manual.*

## 2.7 Maintenance benefits

### 2.7.1 Complete operation display by LCD user's interface

The LCD user's interface display menu allows to check all the important parameters and status of the unit in any moment. Most of these variables are the same ones that can be consulted by 7-segment, taking information from the outdoor unit.

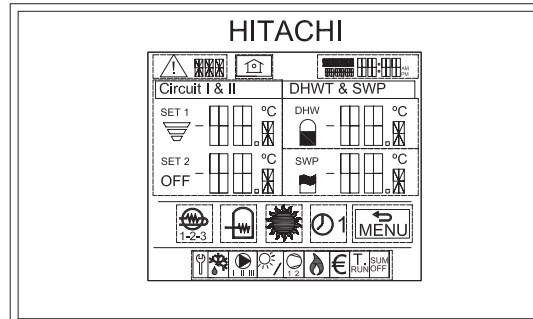

- System operation: Heating mode, DHW, SWP, ...
- Unit status: Display of more specific parameters (indoor/outdoor expansion valve opening, inverter operation frequency, defrosting, ...).
- Actual temperature: A large serie of operation temperatures (water inlet/outlet temperature, room temperature of circuits 1 and 2, outdoor ambient temperature, gas/liquid temperature, ...).
- Set-point: The set-point temperatures will be displayed in order to allow to the user/installer compare the actual and setting temperatures in any moment (room temperature and OTC supply temperature set-point of circuits 1 and 2, water temperature setting, ...).

Additionally, a large variety of parameters can be set by the installer (most of them also by the user) helping with the service works and resulting in a very dynamic system work.

### 2.7.2 Front access to the electrical box

By removing the indoor unit front cover and the electrical box cover it is possible to have a frontal access to the electrical box components (terminal boards 1 and 2, transformer, etc.), allowing an easy service work.

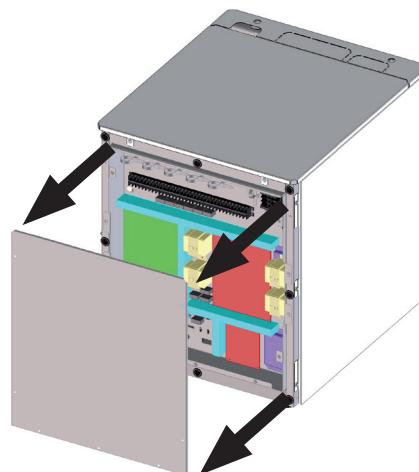

### 2.7.3 Easy servicing

The YUTAKI S80 design allows that the most important components can be accessible and extracted from the front side of the unit. For example, the electrical box can be easily extracted from the unit's front side only disconnecting the wire-to-wire connection

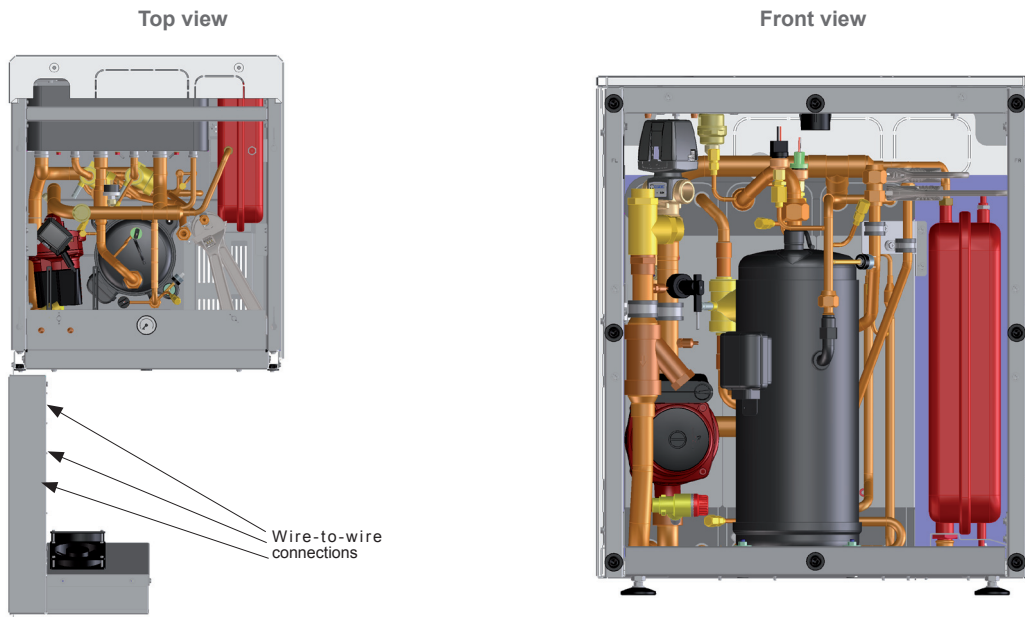

### 2.7.4 High accessibility to the water pressure ports

Water pressure ports for installation commissioning are accessible only removing the indoor unit front and upper cover.

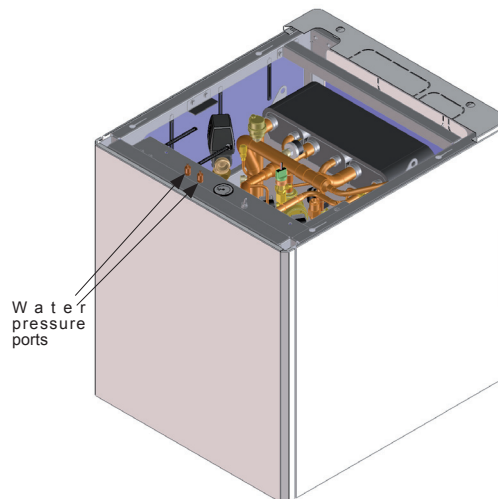

### 2.7.5 Alarm historical data

This option is available in order to facilitate a knowledge of the last alarms registered on the LCD user's interface.

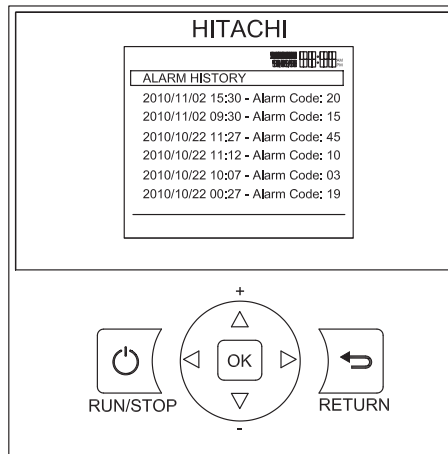

The software can save up to the last 20 alarms, showing on the screen the following data:

- Date
- Time
- Alarm code



# 3. General data

## Index

3.1. YUTAKI S80 system.....	56
3.2. Outdoor unit.....	57
3.2.1. RAS-(4-6)HVRNME-AF .....	57
3.2.2. RAS-(4-6)HRNME-AF .....	58
3.3. Indoor unit .....	59
3.3.1. RWH-(4.0-6.0)FSVNFE .....	59
3.3.2. RWH-(4.0-6.0)FSNFE .....	60
3.4. Domestic Hot Water Tank.....	61
3.5. Component data.....	62
3.5.1. Outdoor unit.....	62
3.5.2. Indoor unit.....	64
3.6. Electrical data.....	65
3.6.1. Considerations.....	65
3.6.2. Outdoor unit.....	65
3.6.3. Indoor unit.....	65
3.6.4. Domestic Hot Water Tank - Electrical heater .....	66

### 3.1 YUTAKI S80 system

Model	Indoor unit		RWH-4.0FS(V)NFE	RWH-5.0FS(V)NFE	RWH-6.0FS(V)NFE		
	Outdoor unit		RAS-4H(V)RNME-AF	RAS-5H(V)RNME-AF	RAS-6H(V)RNME-AF		
Heating capacity	Nominal conditions	(Nominal) ① Conditions: Water inlet/outlet: 30/35°C Outdoor temperature: (DB/WB): 7/6 °C	kW	10.0	12.0	14.0	
		COP	-	4.36	4.27	4.05	
		(Nominal) ② Conditions: Water inlet/outlet: 40/45°C Outdoor temperature: (DB/WB): 7/6 °C	kW	10.0	12.0	14.0	
		COP	-	3.45	3.42	3.32	
		(Nominal) ③ Conditions: Water inlet/outlet: 47/55°C Outdoor temperature: (DB/WB): 7/6 °C	kW	10.0	12.0	14.0	
		COP	-	3.04	3.02	3.01	
		(Nominal) ④ Conditions: Water inlet/outlet: 55/65°C Outdoor temperature: (DB/WB): 7/6 °C	kW	10.0	12.0	14.0	
		COP	-	2.56	2.56	2.51	
		Additional conditions	(Nominal) ⑤ Conditions: Water inlet/outlet: (*)/35°C Outdoor temperature: (DB/WB): -7/-8 °C	kW	7.6	9.0	9.4
			COP	-	2.36	2.32	2.29
			(Nominal) ⑥ Conditions: Water inlet/outlet: (*)/45°C Outdoor temperature: (DB/WB): -7/-8 °C	kW	10.0	12.0	14.0
			COP	-	2.30	2.30	2.25
	Additional conditions	(Nominal) ⑦ Conditions: Water inlet/outlet: (*)/55°C Outdoor temperature: (DB/WB): -7/-8 °C	kW	10.0	12.0	14.0	
		COP	-	2.15	2.15	2.10	
		(Nominal) ⑧ Conditions: Water inlet/outlet: (*)/65°C Outdoor temperature: (DB/WB): -7/-8 °C	kW	10.0	12.0	14.0	
		COP	-	2.00	1.91	1.81	

#### NOTE

- **The nominal heating capacity is based on the EN 14511 standard: Piping length: 7.5 meters; Piping lift: 0 meters.**
- **(\*) Water inlet temperature is not fixed for additional conditions. The test is performed fixing the flow rate obtained during the test at nominal conditions:**
  - Outdoor temperature: (DB/WB): 7/6 °C
- **DB: dry bulb; WB: wet bulb.**



## 3.2 Outdoor unit

### 3.2.1 RAS-(4-6)HVRNME-AF

Model			RAS-4HVRNME-AF	RAS-5HVRNME-AF	RAS-6HVRNME-AF
Electrical power supply			1~ 230V 50Hz		
Color (Munsell code)			- Natural gray (1.0Y8.5/0.5)		
Sound pressure level		dB(A)	46	48	50
Sound power level		dB(A)	65	67	69
Outside measurements	Height	mm	1,380	1,380	1,380
	Width	mm	950	950	950
	Depth	mm	370	370	370
Net weight		kg	103	104	104
Refrigerant		-	R-410A		
Flow control		-	Microprocessor-controlled expansion valve		
Compressor		-	DC inverter driven		
Quantity	Quantity	-	1	1	1
	Power	kW	1.80	2.50	2.50
Heat exchanger		-	Multi-pass cross-finned tube		
Outdoor fan		-	Propeller fan		
Quantity	Quantity	-	2	2	2
	Air flow rate	m <sup>3</sup> /min	80	90	100
	Power	W	70+70	70+70	70+70
Refrigerant pipe connection		-	Flare-nut connection (factory supplied)		
Size	Liquid piping	mm (in)	Ø9.53 (3/8")	Ø9.53 (3/8")	Ø9.53 (3/8")
	Gas piping	mm (in)	Ø15.88 (5/8")	Ø15.88 (5/8")	Ø15.88 (5/8")
Refrigerant charge		kg	3.90	4.00	4.00
Maximum current		A	18.0	23.0	23.0
Packaging measurements		m <sup>3</sup>	0.70	0.70	0.70

#### NOTE

**The sound pressure level is based on following conditions:**

- 1 meter from the frontal surface of the unit; 1.5 meters from floor level.
- Voltage of the power source is 230V.

**The above data is measured in an anechoic chamber, so reflected sound should be taken into consideration when installing the unit.**

### 3.2.2 RAS-(4-6)HRNME-AF

Model			RAS-4HRNME-AF	RAS-5HRNME-AF	RAS-6HRNME-AF
Electrical power supply			3N~ 400V 50Hz		
Color (Munsell code)		-	Natural gray (1.0Y8.5/0.5)		
Sound pressure level		dB(A)	46	48	50
Sound power level		dB(A)	65	67	69
Outside measurements	Height	mm	1,380	1,380	1,380
	Width	mm	950	950	950
	Depth	mm	370	370	370
Net weight		kg	107	108	108
Refrigerant		-	R-410A		
Flow control		-	Microprocessor-controlled expansion valve		
Compressor		-	DC inverter driven		
Quantity			1	1	1
	Power	kW	2.20	3.00	3.00
Heat exchanger		-	Multi-pass cross-finned tube		
Condenser fan		-	Propeller fan		
Quantity			1+1	1+1	1+1
	Air flow rate	m <sup>3</sup> /min	80	90	100
	Power	W	70+70	70+70	70+70
Refrigerant pipe connection		-	Flare-nut connection (factory supplied)		
Size	Liquid piping	mm (in)	Ø9.53 (3/8")	Ø9.53 (3/8")	Ø9.53 (3/8")
	Gas piping	mm (in)	Ø15.88 (5/8")	Ø15.88 (5/8")	Ø15.88 (5/8")
Refrigerant charge		kg	3.90	4.00	4.00
Maximum current		A	7.0	11.0	13.0
Packaging measurements		m <sup>3</sup>	0.70	0.70	0.70

#### NOTE

*The sound pressure level is based on following conditions:*

- 1 meter from the frontal surface of the unit; 1.5 meters from floor level.
- Voltage of the power source is 400V.

*The above data is measured in an anechoic chamber, so reflected sound should be taken into consideration when installing the unit.*

### 3.3 Indoor unit

#### 3.3.1 RWH-(4.0-6.0)FSVNFE

Model		RWH-4.0FSVNFE	RWH-5.0FSVNFE	RWH-6.0FSVNFE
Electrical power supply	-	1~ 230V 50Hz		
Pump input power	W	140	140	140
Maximum current	A	24.0	28.0	31.0
Nominal water flow (condition ①)	m³/h	1.7	2.1	2.4
Unit dimensions	Height	mm 706 (*1)		
	Width	mm 595		
	Depth	mm 695		
Packaging dimensions	Height	mm 837		
	Width	mm 770		
	Depth	mm 720		
Net weight	kg	157	162	162
Packaging dimensions	m³	0.46		
Refrigerant	-	R-134a		
Flow control	-	Microprocessor-controlled expansion valve		
Compressor type	-	DC inverter driven hermetic scroll		
Quantity	Quantity	-	1	1
	Power	kW	3.0	3.0
Refrigerant charge	kg	2.5		
Refrigerant pipe connection	-	Flare nut connection (*2)		
Dimensions	Liquid pipe	mm Ø 9.53 (3/8")		
	Gas pipe	mm Ø 15.88 (5/8")		
Water pipe connection	-	Screwed connections		
Space heating	Inlet diameter	inch Flexible pipe (G 1" male)		
	Outlet diameter	inch Flexible pipe (G 1" male)		
DHW	Inlet diameter	inch Flexible pipe (G 3/4" male)		
	Outlet diameter	inch Flexible pipe (G 3/4" male)		
Expansion vessel volume	l	12		
Color	-	White (RAL 9016)		

#### **i** NOTE

- **(\*1): Dimensions with the minimum mounting foot height. This value can be adjusted up to +30 mm.**
- **(\*2): Refrigerant liquid/gas piping accessory is factory-supplied in order to assist in the refrigerant pipe connection. In this case the connection to the field refrigerant pipe must be brazed. For more information, please refer to the Installation and operation manual.**

### 3.3.2 RWH-(4.0-6.0)FSNFE

Model		RWH-4.0FSNFE	RWH-5.0FSNFE	RWH-6.0FSNFE
Electrical power supply		- 3N~ 400V 50Hz		
Pump input power		W 140	140	140
Maximum current		A 15.0	15.0	15.0
Nominal water flow (condition ①)		m³/h 1.7	2.1	2.4
Unit dimensions	Height	mm	706 (*1)	
	Width	mm	595	
	Depth	mm	695	
Packaging dimensions	Height	mm	837	
	Width	mm	770	
	Depth	mm	720	
Net weight		kg 162	167	167
Packaging dimensions		m³ 0.46		
Refrigerant		- R-134a		
Flow control		- Microprocessor-controlled expansion valve		
Compressor type		- DC inverter driven hermetic scroll		
	Quantity	-	1	1
	Power	kW 3.0	3.0	3.0
Refrigerant charge		kg 2.5		
Refrigerant pipe connection		- Flare nut connection (*2)		
Dimensions	Liquid pipe	mm	Ø 9.53 (3/8")	
	Gas pipe	mm	Ø 15.88 (5/8")	
Water pipe connection		- Screwed connections		
Space heating	Inlet diameter	inch	Flexible pipe (G 1" male)	
	Outlet diameter	inch	Flexible pipe (G 1" male)	
DHW	Inlet diameter	inch	Flexible pipe (G 3/4" male)	
	Outlet diameter	inch	Flexible pipe (G 3/4" male)	
Expansion vessel volume		l 12		
Color		- White (RAL 9016)		

#### **i** NOTE

- (\*1): Dimensions with the minimum mounting foot height. This value can be adjusted up to +30 mm.
- (\*2): Refrigerant liquid/gas piping accessory is factory-supplied in order to assist in the refrigerant pipe connection. In this case the connection to the field refrigerant pipe must be brazed. For more information, please refer to the Installation and operation manual.

### 3.4 Domestic Hot Water Tank

Model				DHWS195S-2.0H1E	DHWS260S-2.0H1E		
Casing	Color			White (RAL 9016)			
	Material			Stainless steel			
Dimensions	Unit	Height	Separated tank	mm	1272 (*1)	1602 (*1)	
			Integrated tank	mm	1940 (*1)	2270 (*1)	
		Width		mm	595		
		Depth		mm	600		
	Packing	Height			mm	1399	1729
			Width		mm	610	
		Depth		mm	770		
		Volume		m <sup>3</sup>	0.66	0.81	
Weight	Net			kg	72	87	
	Gross			kg	82	98	
Packing	Material			Carton			
				Wood			
				Plastic			
Main components	Tank	Net water volume		L	185	250	
		Material		AISI 444			
		Max. tank working temperature		°C	75		
		Max. tank water working pressure		bar	6		
		Max. heating coil water working temperature		°C	75		
		Max. heating coil water working pressure		bar	3		
Tank	Insulation	Material			NEOPOR		
		Thickness		mm	50		
Main components	Heat exchanger	Quantity			1		
		Coil surface area		m <sup>2</sup>	1.4		
	Tank's heater	Quantity			1		
		Heater rating		kW	2.0		
		Type			Immersion heater type		
Piping connections	Water inlet domestic connection			in.	Flexible pipe (G 3/4" male)		
	Water outlet domestic connection			in.	Flexible pipe (G 3/4" male)		
	In coil connection			in.	Flexible pipe (G 3/4" male)		
	Out coil connection			in.	Flexible pipe (G 3/4" male)		
Mechanical thermostat (adjustable and security)				Yes			
Protection				Anode protection			

3

***i*** NOTE

(\*1): Dimensions with the minimum mounting foot height. This value can be adjusted up to +30 mm.

### 3.5 Component data

#### 3.5.1 Outdoor unit

##### ◆ RAS-(4-6)HVRNME-AF

Model			RAS-4HVRNME-AF	RAS-5HVRNME-AF	RAS-6HVRNME-AF	
Heat exchanger	Heat exchanger type		-	Multi-pass cross-finned tube		
	Piping	Material	-	Copper piping		
		Outer diameter	Ømm	7	7	7
		Rows	-	2	2	2
		Number of tubes/coil	-	134	134	134
		Fin		-	Aluminum	
		Pitch	mm	1.9	1.9	1.9
	Maximum operating pressure		MPa	4.15	4.15	4.15
	Total face area		m <sup>2</sup>	1.35	1.35	1.35
	Number of coils/unit		-	1	1	1
Fan unit	Fan	Type	-	Multi-blade centrifugal fan		
		Number/unit	-	2	2	2
		Outer diameter	mm	544	544	544
		Revolutions	rpm	376+459	516+422	573+469
		Nominal air flow/fan	m <sup>3</sup> /min	80	90	100
	Motor	Type	-	Drip-proof enclosure		
		Starting method	-	DC control		
		Power	W	70+70	70+70	70+70
		Quantity	-	2	2	2
		Insulation class	-	E	E	E
Compressor	Model		-	E-306AHD-27A2	E-406AHD-36A2	E-406AHD-36A2
	Type		-	Hermetic scroll		
	Pressure resistance	Discharge	MPa	4.15	4.15	4.15
		Suction	MPa	2.21	2.21	2.21
	Motor type	Starting method	-	Inverter-driven (I.D.)		
		Poles	-	4	4	4
		Insulation class	-	E	E	E
	Oil type		-	FVC68D	FVC68D	FVC68D
	Oil quantity		l	1.2	1.2	1.2

**◆ RAS-(4-6)HRNME-AF**

Model			RAS-4HRNME-AF	RAS-5HRNME-AF	RAS-6HRNME-AF		
Heat exchanger	Heat exchanger type		-	Multi-pass cross-finned tube			
	Piping	Material	-	Copper piping			
		Outer diameter	Ømm	7	7	7	
		Rows	-	2	2	2	
		Number of tubes/coil	-	134	134	134	
	Fin	Material	-	Aluminum			
		Pitch	mm	1.9	1.9	1.9	
	Maximum operating pressure		MPa	4.15	4.15	4.15	
	Total face area		m <sup>2</sup>	1.35	1.35	1.35	
Number of coils/unit		-	1	1	1		
Fan unit	Fan	Type	-	Multi-blade centrifugal fan			
		Number/unit	-	2	2	2	
		Outer diameter	mm	544	544	544	
		Revolutions	rpm	376+459	516+422	573+469	
		Nominal air flow/fan	m <sup>3</sup> /min	80	90	100	
	Motor	Type	-	Drip-proof enclosure			
		Starting method	-	DC control			
		Power	W	70+70	70+70	70+70	
		Q'ty	-	2	2	2	
		Insulation class	-	E	E	E	
	Compressor	Model		-	E-305AHD-27D2	E-405AHD-36D2	E-405AHD-36D2
		Type		-	Hermetic scroll		
Pressure resistance		Discharge	MPa	4.15	4.15	4.15	
		Suction	MPa	2.21	2.21	2.21	
Motor type		Starting method	-	Inverter-driven (I.D.)			
		Poles	-	4	4	4	
		Insulation class	-	E	E	E	
Oil type		-	FVC68D	FVC68D	FVC68D		
Oil quantity		l	1.2	1.2	1.2		

3

### 3.5.2 Indoor unit

Model			RWH-4.0FS(V)NFE			RWH-5.0FS(V)NFE			RWH-6.0FS(V)NFE			
Compressor	Model	1~ 230V 50Hz	-	H405DHD-64A1			H405DHD-64A1			H405DHD-64A1		
		3N~ 400V 50Hz	-	H405DHD-64D1			H405DHD-64D1			H405DHD-64D1		
	Type		-	Hermetic scroll								
	Pressure resistance	Discharge	MPa	2.94			2.94			2.94		
		Suction	MPa	0.15			0.15			0.15		
	Motor type	Starting method	-	Inverter-driven (I.D.)								
		Poles	-	4			4			4		
		Insulation class	-	E			E			E		
Oil type		-	FVC68D			FVC68D			FVC68D			
Oil quantity		l	1.2			1.2			1.2			
Heat exchanger	Material		-	Stainless steel								
	Transfer fluids		-	R410A	R134a	R410A	R410A	R134a	R410A	R410A	R134a	R410A
				H <sub>2</sub> O	H <sub>2</sub> O	R134a	H <sub>2</sub> O	H <sub>2</sub> O	R134a	H <sub>2</sub> O	H <sub>2</sub> O	R134a
	Quantity		-	1	1	1	1	1	1	1	1	
	Dimensions	Height (H)	mm	526								
		Width (W)	mm	119								
		Depth (D)	mm	93.6	93.6	125	125	125	125	125	125	125
	Piping	Refrigerant connection	mm (in)	Ø15.88 (5/8")	Ø15.88 (5/8")	Ø15.88 (5/8") - Ø28.6 (1-1/8")	Ø15.88 (5/8")	Ø15.88 (5/8")	Ø15.88 (5/8") - Ø28.6 (1-1/8")	Ø15.88 (5/8")	Ø15.88 (5/8")	Ø15.88 (5/8") - Ø28.6 (1-1/8")
		Water connection	mm (in)	Ø28.6 (1-1/8")	Ø28.6 (1-1/8")	-	Ø28.6 (1-1/8")	Ø28.6 (1-1/8")	-	Ø28.6 (1-1/8")	Ø28.6 (1-1/8")	-
	Maximum refrigerant operating pressure	MPa	4.5	4.5	4.5	4.5	4.5	4.5	4.5	4.5	4.5	
	Maximum water operating pressure	MPa	3.6	3.6	-	3.6	3.6	-	3.6	3.6	-	
	Internal refrigerant volume	l	2.11	2.11	2.89 + 3.00	2.89	2.89	2.89 + 3.00	2.89	2.89	2.89 + 3.00	
Internal water volume	l	2.22	2.22	-	3.00	3.00	-	3.00	3.00	-		
Pump	Model		-	UPS25-80/180								
	Type		-	Glandless								
	Power supply		-	1~ 230V 50Hz								
	Maximum lift pressure	kPa		61			62			62		
	Maximum water flow	m <sup>3</sup> /h		2.9			3.1			3.1		
	Piping	Water inlet	(in)	1-1/2" G								
Water outlet		(in)	1-1/2" G									
Inlet/outlet distance		mm	180									
Expansion vessel	Material		-	Steel (with stainless/galvanized steel connections)								
	Internal water volume	l	12									
	Dimensions	Height (H)	mm	435								
		Width (W)	mm	343								
		Depth (D)	mm	98								
	Working pressure	MPa	0.3									
Pre-loading pressure (Air side)	MPa	0.08										
Water strainer	Type		-	Y shape								
	Material		-	Brass								
	Piping connection	(in)	DI 41.4 (brazed)									
	Mesh (hole size)	mm	0.5									



## 3.6 Electrical data

### 3.6.1 Considerations

Key words:

- PH: Phase.
- IPT: Total input power.
- STC: Starting current: Less than maximum current.
- RNC: Running current.
- MC: Maximum current.
- CB: Recommended circuit breaker.
- ELB: Earth leakage breaker.

#### **i** NOTE

- **Heating inlet/outlet water temperature condition: 55/65 °C.**
- **Outdoor ambient temperature (DB/WB): 7/6 °C**
- **Specifications in these tables are subject to change without notice in order that HITACHI may bring the latest innovations to their customers.**

### 3.6.2 Outdoor unit

Model	Power supply	Applicable voltage		Compressor and fan motors			Max. IPT (kW)	MC (A)	CB (A)	ELB (n° poles/A/mA)
		U max. (V)	U min. (V)	STC (A)	IPT (kW)	RNC (A)				
RAS-4HVRNME-AF	1~ 230V 50Hz	253	207	-	2.06	9.2	3.94	18.0	20	2/40/30
RAS-5HVRNME-AF					2.62	11.6	5.75	23.0	25	
RAS-6HVRNME-AF					3.27	14.5	5.86	23.0	25	
RAS-4HRNME-AF	3N~ 400V 50Hz	440	360		2.06	3.0	4.72	7.0	15	4/40/30
RAS-5HRNME-AF					2.62	3.9	6.76	11.0	20	
RAS-6HRNME-AF					3.27	4.8	8.16	13.0	20	

### 3.6.3 Indoor unit

Model	Power supply	Applicable voltage		Indoor unit system		Max. IPT (kW)	MC (A)	CB (A)	ELB (n° poles/A/mA)
		U max. (V)	U min. (V)	RNC (A)	IPT (kW)				
RWH-4.0FSVNFE	1~ 230V 50Hz	253	207	12.2	2.73	5.41	24.0	32	2/40/30
RWH-5.0FSVNFE				12.5	2.78	6.31	28.0	32	
RWH-6.0FSVNFE				14.5	3.23	6.98	31.0	32	
RWH-4.0FSNFE	3N~ 400V 50Hz	440	360	6.0	2.73	4.80	15.0	15	4/40/30
RWH-5.0FSNFE				6.1	2.78	4.80	15.0	15	
RWH-6.0FSNFE				7.0	3.23	4.80	15.0	15	

### 3.6.4 Domestic Hot Water Tank - Electrical heater

Model	Power supply	Applicable voltage		IPT (kW)	RNC (A)
		U max. (V)	U min. (V)		
DHWS195S-2.0H1E	1~ 230V 50Hz	253	207	2.0	8.7
DHWS260S-2.0H1E					

 **NOTE**

(\*1): If it is desired to enable the DHW tank heater operation during normal indoor unit operation, adjust the DSW4 pin 1 of the PCB1 to the ON position and use these protections: CB=40A for single phase (1~) or CB=25A for three phase (3N~).

 **DANGER**

Never connect the DHW tank to the main power supply. Always connect it to the YUTAKI S80 indoor unit as explained in its Installation and operation manual.

# 4. Capacity and selection data

## Index

4.1. System selection procedure .....	68
4.1.1. Selection parameters.....	68
4.1.2. Selection procedure.....	68
4.2. Maximum heating capacity tables .....	76
4.3. Correction factors .....	77
4.3.1. Defrost correction factor .....	77
4.3.2. Piping length correction factor .....	77

## 4.1 System selection procedure

The following procedure gives an example of selection of YUTAKI S80 system based on a series of previously defined installation requirements: heating load required, operating temperatures and special characteristics on the installation (energy system used, power source, etc.).

### 4.1.1 Selection parameters

To calculate the YUTAKI S80 units, it will be necessary to consult and/or use a series of parameters shown in tables and graphics presented in the different chapters of this catalogue. A summarized list is shown below:

<i>Available models</i>	<i>Maximum heating capacities</i>
<i>General information of the units</i>	<i>COP</i>
<i>Operation space possibilities</i>	<i>Different correction factors</i>
<i>Working range</i>	<i>Sound data for the different units</i>
<i>Different possible energy systems</i>	

### 4.1.2 Selection procedure

The system selection procedure is as follows:

Firstly, the system combination (outdoor unit + indoor unit) is pre-selected according to the design conditions. Then, the theoretical capacity values taken from the different maximum heating capacity tables are corrected by means of the correction factors explained in the following pages, resulting in the actual capacity which will provide the selected system. The DHW tank will be selected depending on the daily water needs.

#### ◆ Installation configurations

YUTAKI S80 allows many configuration possibilities which are detailed on chapter [Installation configurations](#).

Then, the three main types of configuration are described briefly and are taken into account in the selection procedure in order to provide the best solution for the heating requirements.

Before proceeding with the selection calculation, first the system type to design has to be established: Mono-valent, Mono-energy, or Alternating Bi-valent. These main energy systems with their capacity-time charts are shown below.

#### NOTE

**For more information about the various energy systems, please refer to the chapter [Installation configurations](#).**

### Mono-valent system

The YUTAKI S80 is sized to provide 100% of the heating requirements on the coldest day of the year.

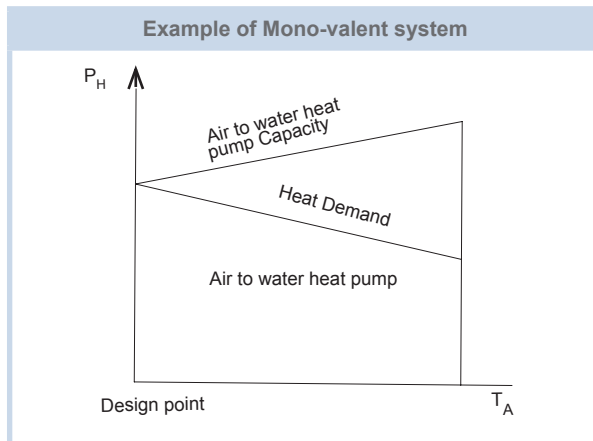

**i** NOTE

- $T_A$ : Outdoor ambient temperature.
- $P_H$ : Heating capacity.

### Mono-energy system

The YUTAKI S80 is sized to provide approximately 80% of the heating requirements in the coldest days of the year. An auxiliary electric heater (as accessory) is used to provide the additional heating required on cold days.

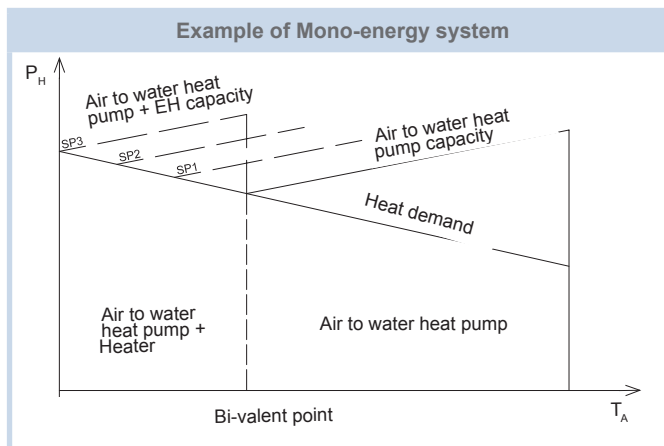

**i** NOTE

- $T_A$ : Outdoor ambient temperature.
- $P_H$ : Heating capacity.
- SP1/2/3: Heater steps.
- Bivalent point can be set through the LCD user's interface.

### Alternating Bi-valent system

The boiler is configured to alternate with the split air to water heat pump. A hydraulic separator or buffer tank has to be used to ensure hydraulic balancing.

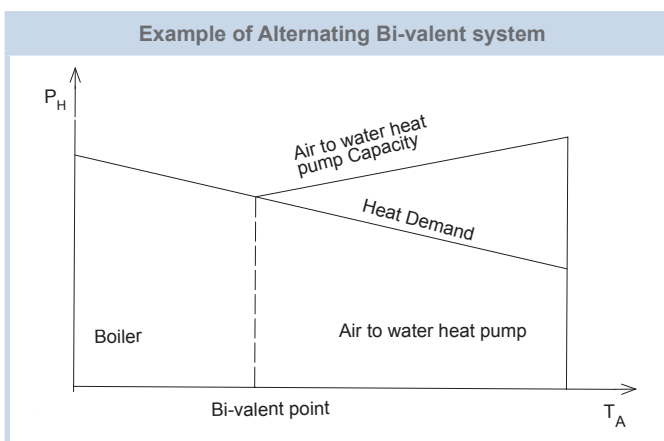

**i** NOTE

- $T_A$ : Outdoor ambient temperature.
- $P_H$ : Heating capacity.
- Bivalent point can be set through the LCD user's interface.

### ◆ Procedure description

Follow the next selection procedure given in this chapter:

- a. System combination (outdoor unit + indoor unit) selection
  - i. Without heating source (Mono-valent system)
  - ii. With additional heating source (Mono-energy / Bivalent system)
- b. It will be selected the domestic hot water tank accessory (optional).

#### a.i) Mono-valent system (regular election)

In case of normal selection of Mono-valent system (without additional heating sources) the YUTAKI S80 will be selected depending on the required heating load.

### **i** NOTE

*The example given in this chapter is the regular election as the YUTAKI S80 has been performed to cover all the heating requirements, even the coldest days of the year.*

#### • Step 1: Initial pre-selection

Proposed energy system	Mono-valent
Inlet/outlet water temperature	47/55 °C
Ambient temperature WB/DB in the coldest day of the year (HR = 85%)	-10/-9 °C
Heating load required on the coldest day of the year	13.0 kW
<b>Installation restrictions</b>	
Installation type	Radiant floor
Power supply	1~ 230V 50Hz
Indoor unit lower than outdoor unit	15 m
Equivalent piping length between outdoor and indoor unit	20 m

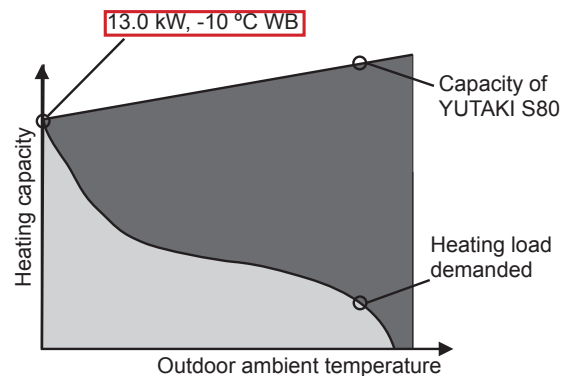

These conditions will determine the entry in the maximum heating capacity tables (see section [Maximum heating capacity tables](#)) where it is possible to identify which unit has the heating capacity to cover the required heating load on the coldest day of the year by the installation (13.0 kW for an inlet/outlet water temperature of 47/55 °C and an ambient temperature of -10°C WB).

YUTAKI S80	Maximum heating capacity (kW)
RAS-4H(V)RNME-AF + RWH-4.0FS(V)NFE	13.0
<b>RAS-5H(V)RNME-AF + RWH-5.0FS(V)NFE</b>	<b>15.6</b>
RAS-6H(V)RNME-AF + RWH-6.0FS(V)NFE	17.6

### **i** NOTE

*Although the RAS-4HVRNME-AF + RWH-4.0FS(V)NFE combination has the same maximum heating capacity than the heating load required, we must take the next combination cause this heating capacity will be lower after applying the correction factors (step 2).*

As it is visible in the table, the YUTAKI S80 system that covers the installation's heating requirements is the combination of RAS-5HVRNME-AF + RWH-5.0FS(V)NFE. Therefore, this will be the pre-selected YUTAKI S80 system.

**i NOTE**

**In case of working with an ambient temperature value not included in the Maximum heating capacity tables of section [Maximum heating capacity tables](#), (for example, -3 °C), an interpolation will be needed, using the values above and below the ambient temperature.**

- **Step 2: Heating capacity correction for defrost and piping length**

The actual heating capacity of the pre-selected unit must be calculated applying the necessary correction factors:

$$Q_H = Q_{MH} \times f_D \times f_{LH}$$

$Q_H$ : Actual heating capacity (kW)

$Q_{MH}$ : Maximum heating capacity (kW)

$f_D$ : Defrost correction factor

$f_{LH}$ : Heating piping length correction factor

The maximum heating capacity ( $Q_{MH}$ ) of the RAS-5H(V)RNME-AF + RWH-5.0FS(V)NFE system is 15.6 kW.

- Calculation of  $f_D$ :

In situations where the ambient temperature is lower than 7 °C DB, the frost may build up on the heat exchanger. In this case, the heating capacity of the system may be reduced because of the time spent by the system in removing the frost build-up.

The defrosting correction factor takes into account this time and applies the heating capacity correction.

To calculate the correction factor, please see section [Defrost correction factor](#) which shows a table with different values of  $f_D$  depending on the ambient temperature (°C DB). If the correction factor at an ambient temperature does not appear on the table, an interpolation will be needed.

Finally, the resulting defrosting correction factor for our outdoor ambient temperature of -10°C WB is **0.89**.

- Calculation of  $f_{LH}$ :

Both, the length of the refrigerant piping used and the height difference between the outdoor unit and the indoor unit, directly affect the unit performance. This concept is quantified by means of the piping length correction factor.

To determine this value, it is necessary refer to section [Heating piping length correction factor](#), where it can be seen the characteristics of this example: equivalent piping length of 20 meters and the indoor unit is located 15 meters lower than outdoor unit. The resulting piping length correction factor is **0.993**.

- Calculation of  $Q_H$ :

Once the correction factors to be applied have been determined, the formula for actual heating capacity of the RAS-5H(V)RNME-AF + RWH-5.0FS(V)NFE system can be applied:

$$Q_H = 15.6 \text{ kW} \times 0.89 \times 0.993 = \mathbf{13.77 \text{ kW}}$$

As it can be seen, the actual heating capacity of the RAS-5H(V)RNME-AF + RWH-5.0FS(V)NFE system (13.77 kW) is greater than the heating load required by the installation (13.0 kW). Therefore, the pre-selection will be considered valid.

**i NOTE**

**If the actual heating capacity calculated is lower than the required heating load, the calculation must be done again with the unit immediately above. If there is no unit higher than the pre-selected one, some other system (combination with boiler or electric heater accessory for example) should be considered.**

### a.ii) Use of auxiliary heating source (electric heater or boiler combination)

In installations which already have a conventional boiler (gas/oil), it can be used to alternate with YUTAKI S80 (Bi-valent system) which it will help to increase the overall performance of the whole installation significantly.

Equally, if an additional heat load is required, an electric heater can be installed as accessory for the Mono-energy system.

In any case, the Procedure description explained before can be applied to all the energy systems mentioned but including a heat load check when using auxiliary heating source (Mono-energy or Bi-valent systems) and recalculating the new heating points.

It will be checked that the combination (YUTAKI S80 + electric heater / boiler) covers the temporary needs in the coldest days of the year.

Mono-energy and Bi-valent systems are useful when there is a constant regular heating load and low periods of heating load peaks related to the coldest days of the year.

#### **i** NOTE

*The following check can be used as well for the two combinations.*

#### • Step 1: Initial pre-selection

Proposed energy system	Mono-energy
Inlet/outlet water temperature	47/55 °C
Regular ambient temperature WB/DB (HR = 85%)	-5/-4 °C
Required regular heating load	9.0 kW
Ambient temperature WB/DB on the coldest day of the year (HR = 85%)	-10/-9 °C
Heating load required on the coldest day of the year	13.0 kW

Installation restrictions	
Installation type	Radiant floor
Power supply	1~ 230V 50Hz
Indoor unit lower than outdoor unit	15 m
Equivalent piping length between outdoor and indoor unit	20 m

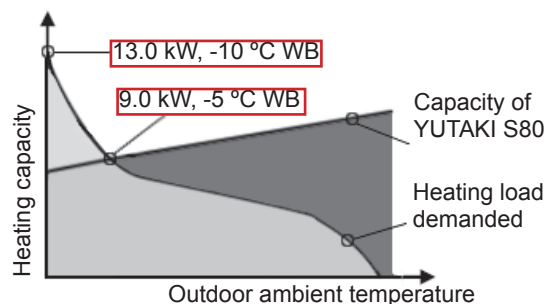

In this new system the heat pump meets with the regular heating load. To reach the peak heating load of 13.0 kW (-10 °C WB) necessary in the coldest days of the year the electric heater can provide the auxiliary heating capacity to cover it.



As the heating load has fallen to 9.0 kW as we are considering this point as regular heating load, it may be reselected the needed unit. The RAS-5H(V)RNME-AF + RWH-5.0FS(V)NFE system would provide too much heating capacity so we could take the RAS-4H(V)RNME-AF + RWH-4.0FS(V)NFE system for these new conditions.

YUTAKI S80	Maximum heating capacity (kW)
<b>RAS-4H(V)RNME-AF + RWH-4.0FS(V)NFE</b>	<b>13.4</b>
RAS-6H(V)RNME-AF + RWH-6.0FS(V)NFE	16.0
RAS-6H(V)RNME-AF + RWH-6.0FS(V)NFE	17.9

The maximum heating capacity for this new system for an ambient temperature of -5 °C WB and a water inlet/outlet temperature of 47/55 °C is **13.4 kW**. We follow the same procedure as in point a.i) to apply the correction and the resulting heating capacity for this system is **11.43 kW**.

By help of the Maximum heating capacity tables the heating capacity for the new system has to be calculated for the coldest days conditions (-10°C).

The maximum heating capacity for an ambient temperature of -10 °C WB and a water inlet/outlet temperature of 47/55 °C is **13.0 kW**.

#### • Step 2: Heating capacity correction for defrost and piping length

The actual heating capacity for the system selected in the coldest days of the year is calculated by applying correction factors for defrost and piping length, following the method used above.

$$Q_H = Q_{MH} \times f_D \times f_{LH}$$

$Q_H$ : Actual heating capacity (kW)

$Q_{MH}$ : Maximum heating capacity (kW)

$f_D$ : Defrost correction factor

$f_{LH}$ : Heating piping length correction factor

- Calculation of  $f_D$ :

The resulting defrost correction factor for our outdoor ambient temperature of -10°C WB is **0.89**.

- Calculation of  $f_{LH}$ :

The resulting piping length correction factor is **0.992**.

- Calculation of  $Q_H$ :

Once the correction factors to be applied have been determined, the formula for actual heating capacity of the unit RAS-4H(V)RNME-AF + RWH-4.0FS(V)NFE system can be applied:

$$Q_H = 13.0 \text{ kW} \times 0.89 \times 0.992 = \mathbf{11.47 \text{ kW}}$$

- **Step 3: Calculation for the heating capacity of the combination (case YUTAKI S80 with electric heater)**

Once applied the applicable correction factors, the actual heating capacity provided by the RAS-4H(V)RNME-AF + RWH-4.0FS(V)NFE system is 11.47 kW. This heating capacity does not cover the required heating load for the coldest days (13.0 kW).

In these cases, the water electric heater supplied by HITACHI as accessory (WEH-6E) will provide the auxiliary capacity required to cover temporary heating needs.

The auxiliary electric heater provides a maximum power of 6.0 kW which must be added to the heating capacity provided by the pre-selected unit. The result is:

$$Q_H = 11.47 \text{ kW} + 6 \text{ kW} = 17.47 \text{ kW}$$

In this example, the heating capacity resulting is higher than the heating demand of 13.0 kW estimated for the coldest days of the year, so that pre-selection of the RAS-4H(V)RNME-AF + RWH-4.0FS(V)NFE system can be taken as valid.

The energy system resulting will be the following:

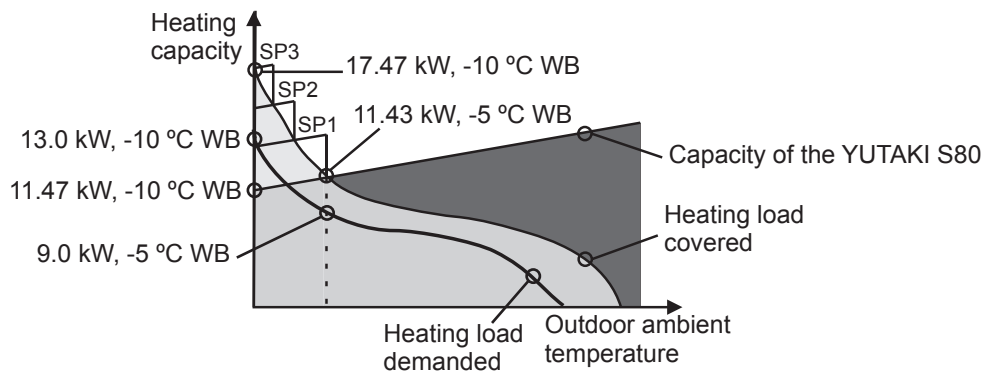

### Three steps electric heater control

As it has been explained in chapter [Features and benefits](#), the desired heating supplied by the electric heater can be more exactly adjusted by means of the 3 steps electric heater control. When the electric heater is working in steps 1 or 2, the power input will be reduced comparing with the total power input of the electric heater.

In this example, this option can be applied. The electric heater can work on 1 step (2.0 kW) and the required heating load for the coldest days will be covered with a reduction of power input. The result will be:

$$Q_H = 11.47 \text{ kW} + 2.0 \text{ kW} = 13.47 \text{ kW}$$

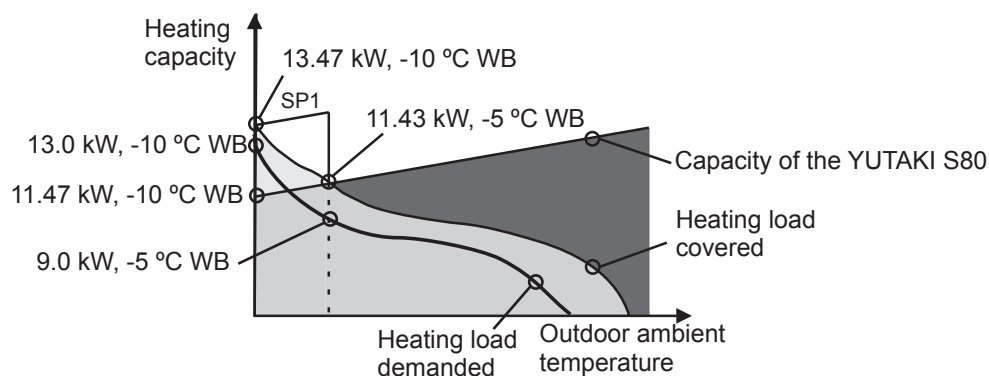

## b) Selection of the Domestic Hot Water Tank accessory

The Domestic Hot Water Tank accessory applicable to the YUTAKI S80 system is the DHWS195S-2.0H1E or DHWS260S-2.0H1E depending on the water demand and the combination system. In order to meet the suitable tank it is necessary to estimate the daily domestic hot water demand. The following expression is used to calculate this consumption:

$$D_i(T) = D_i(60^\circ\text{C}) \times (60 - T_i / T - T_i)$$

Where:

$D_i(T)$ : Water demand at T temperature.

$D_i(60^\circ\text{C})$ : Domestic hot water demand at 60°C.

T: Domestic hot water tank's temperature.

$T_i$ : Inlet cold water temperature.

- Calculation of  $D_i(60^\circ\text{C})$ :

To calculate the domestic hot water demand at 60°C,  $D_i(60^\circ\text{C})$ , it must be referred the current technical installation legislation of the country where the installation will be performed, in order to know the standard liters per person each day. This is necessary to estimate the consumption in relation with the users of the installation. For the next example the domestic hot water demand at 60° it has been taken 30 liters per person, in a detached house with 4 persons (3 bedrooms).

- Calculation of T:

The domestic hot water tank's temperature should be estimated. It is referred to the accumulated water temperature inside the tank, before the use. Habitually the temperature's rank is between 45°C - 65°C. In the example below, it has been taken 45°C.

- Calculation of  $T_i$ :

The inlet cold water temperature is the temperature of the water that is filling the tank. The cold water tank's temperature is 10°C - 15°C. To calculate an approximate water demand it has been used 12°C.

- Example:

$$D_i(T) = 120 \times (60 - 12 / 45 - 12) = 174.6 \text{ litres/day (*)}$$

### **i** NOTE

(\*): Depending on the electric tariff, the installation space and the cost/efficiency relation there are different strategies of accumulation to follow. In case a low cost electric tariff strategy is chosen (accumulation strategy) the daily water demand could double the normal case (semiaccumulation strategy).

The election of the water tank depends on the next table:

Daily water demand	Domestic Hot Water Tank
<185 Litres	DHWS195S-2.0H1E
>185 Litres	DHWS260S-2.0H1E

YUTAKI S80	Domestic Hot Water Tank
RAS-(4/5/6)H(V)RNME-AF + RWH-(4.0/5.0/6.0)FS(V)NFE	DHWS195S-2.0H1E DHWS260S-2.0H1E

### **i** NOTE

- The storage capacity of the tank has to meet with the daily consumption in order to avoid stagnation of water.
- The YUTAKI S80 is designed for combination with HITACHI Domestic Hot Water Tank. In case of another tank is being used in combination with YUTAKI S80, HITACHI cannot guarantee neither good operation or reliability of the system.
- This Domestic Hot Water Tank selection procedure is just orientated, be sure of consulting the local legislation to ensure a good water demand value.

## 4.2 Maximum heating capacity tables

System	Water outlet temp. (°C)	Ambient temperature (°C WB)												
		-20	-15	-10	-8	-5	0	2	5	6	10	11	15	20
		CAP (kW)	CAP (kW)	CAP (kW)	CAP (kW)	CAP (kW)	CAP (kW)	CAP (kW)	CAP (kW)	CAP (kW)	CAP (kW)	CAP (kW)	CAP (kW)	CAP (kW)
RWH-4.0FS(V) NFE + RAS-4H(V) RNME-AF	80	11.2	11.7	12.1	12.3	12.5	12.9	13.1	13.5	13.5	13.5	13.5	13.5	13.5
	75	11.4	11.9	12.3	12.5	12.7	13.1	13.3	13.5	13.5	13.5	13.5	13.5	13.5
	70	11.6	12.1	12.5	12.7	12.9	13.2	13.4	13.5	13.5	13.5	13.5	13.5	13.5
	65	11.7	12.2	12.6	12.8	13.0	13.4	13.5	13.5	13.5	13.5	13.5	13.5	13.5
	60	11.9	12.4	12.8	13.0	13.2	13.5	13.5	13.5	13.5	13.5	13.5	13.5	13.5
	55	12.2	12.6	13.0	13.2	13.4	13.5	13.5	13.5	13.5	13.5	13.5	13.5	13.5
	50	12.5	12.8	13.2	13.4	13.5	13.5	13.5	13.5	13.5	13.5	13.5	13.5	13.5
	45	12.7	13.1	13.4	13.5	13.5	13.5	13.5	13.5	13.5	13.5	13.5	13.5	13.5
	40	7.3	8.3	9.3	9.8	10.5	11.9	12.4	12.7	13.5	13.5	13.5	13.5	13.5
35	7.8	8.9	10.0	10.5	11.2	12.4	12.9	13.2	13.5	13.5	13.5	13.5	13.5	
RWH-5.0FS(V) NFE + RAS-5H(V) RNME-AF	80	13.7	14.4	15.0	15.2	15.4	15.6	15.8	16.0	16.0	16.0	16.0	16.0	16.0
	75	13.8	14.5	15.1	15.3	15.5	15.8	15.9	16.0	16.0	16.0	16.0	16.0	16.0
	70	13.9	14.6	15.2	15.5	15.6	15.8	16.0	16.0	16.0	16.0	16.0	16.0	16.0
	65	14.0	14.7	15.4	15.7	15.8	15.9	16.0	16.0	16.0	16.0	16.0	16.0	16.0
	60	14.1	14.8	15.5	15.8	15.9	16.0	16.0	16.0	16.0	16.0	16.0	16.0	16.0
	55	14.2	14.9	15.6	15.9	16.0	16.0	16.0	16.0	16.0	16.0	16.0	16.0	16.0
	50	14.3	15.0	15.7	16.0	16.0	16.0	16.0	16.0	16.0	16.0	16.0	16.0	16.0
	45	14.5	15.1	15.7	16.0	16.0	16.0	16.0	16.0	16.0	16.0	16.0	16.0	16.0
	40	8.7	9.9	11.1	11.7	12.5	14.2	15.2	15.6	16.0	16.0	16.0	16.0	16.0
35	9.3	10.5	11.8	12.3	13.3	15.0	15.6	15.9	16.0	16.0	16.0	16.0	16.0	
RWH-6.0FS(V) NFE + RAS-6H(V) RNME-AF	80	14.1	15.6	17.0	17.2	17.5	17.8	17.9	18.0	18.0	18.0	18.0	18.0	18.0
	75	14.5	16.0	17.2	17.3	17.6	17.9	18.0	18.0	18.0	18.0	18.0	18.0	18.0
	70	14.8	16.3	17.3	17.4	17.6	17.9	18.0	18.0	18.0	18.0	18.0	18.0	18.0
	65	15.0	16.5	17.4	17.6	17.7	17.8	18.0	18.0	18.0	18.0	18.0	18.0	18.0
	60	15.2	16.7	17.5	17.7	17.8	17.9	18.0	18.0	18.0	18.0	18.0	18.0	18.0
	55	15.3	16.8	17.6	17.9	17.9	18.0	18.0	18.0	18.0	18.0	18.0	18.0	18.0
	50	15.5	17.0	17.7	17.9	18.0	18.0	18.0	18.0	18.0	18.0	18.0	18.0	18.0
	45	15.7	17.1	17.8	18.0	18.0	18.0	18.0	18.0	18.0	18.0	18.0	18.0	18.0
	40	8.9	10.1	11.4	12.3	13.1	15.1	15.6	16.8	17.5	18.0	18.0	18.0	18.0
35	9.5	10.8	12.1	12.6	13.9	16.1	16.2	17.4	18.0	18.0	18.0	18.0	18.0	

### NOTE

- CAP: Capacity at compressor maximum frequency. Capacity is valid for difference between water inlet and water outlet of 3-10°C.

The table above shows the capacity data in peak values (without considering the defrost value). To calculate the integrated values it is necessary to apply the defrost correction factor referring to the section [Defrost correction factor](#).

## 4.3 Correction factors

### 4.3.1 Defrost correction factor

The maximum heating capacity shown above does not include operation during frost or defrosting.

When this type of operation is taken into account, the heating capacity must be corrected according to the following equation:

$$\text{Correction heating capacity} = \text{Correction factor} \times \text{heating capacity}$$

Outdoor inlet air temp. (°C WB) (HR = 85% )	-20	-15	-10	-8	-5	0	2	5	≥6
Defrost correction factor $f_d$	0.90	0.89	0.89	0.88	0.86	0.85	0.85	0.95	1.00

#### **i** NOTE

- **Defrost correction factor corresponds to a relative humidity of 85%. If the condition changes, the correction factor will be different.**
- **Defrost correction factor is not valid for special conditions such as during snow or operation in a transitional period.**

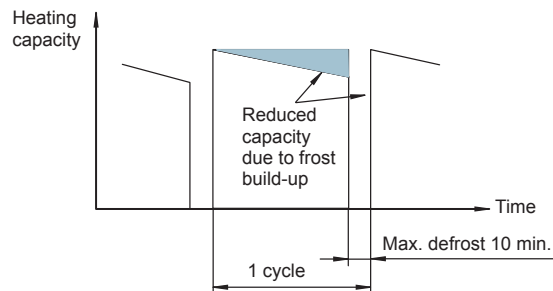

4

### 4.3.2 Piping length correction factor

The correction factor is based on the equivalent piping length in meters (EL) and the height between outdoor and indoor unit in meters (H).

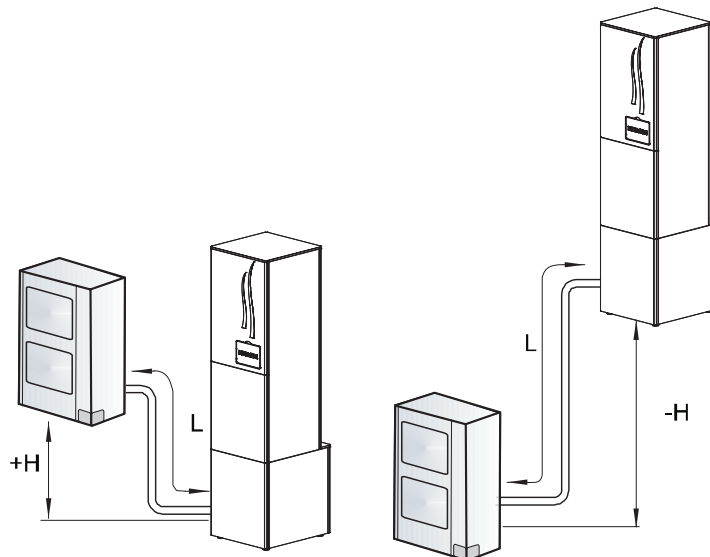

**H:** Height between indoor unit and outdoor unit (m).

- H>0: Position of outdoor unit is higher than position of indoor unit (m).
- H<0: Position of outdoor unit is lower than position of indoor unit (m).

**L:** Actual one-way piping length between indoor unit and outdoor unit (m).

**EL:** Equivalent one-way piping length between indoor unit and outdoor unit (m).

- One 90° elbow is 0,5 m.
- One 180° bend is 1,5 m.

◆ Heating piping length correction factor

**i** NOTE

Take note that the piping length specified in the following graphics is the equivalent piping length (EL), considering the possible elbows, bends... The actual piping length (L) is slightly lower, 30 m.

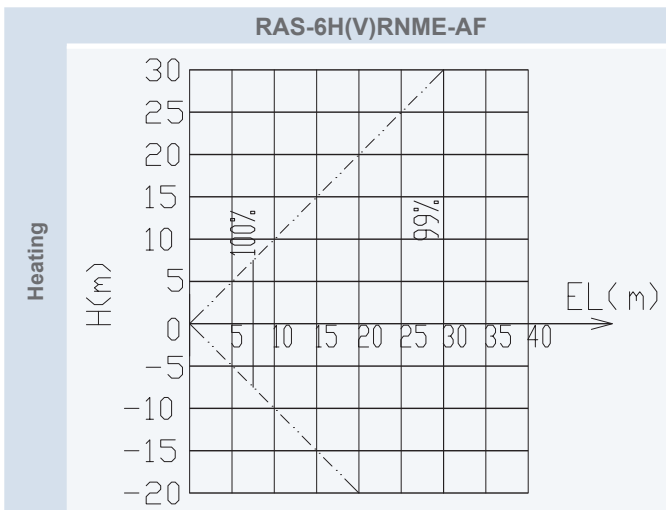
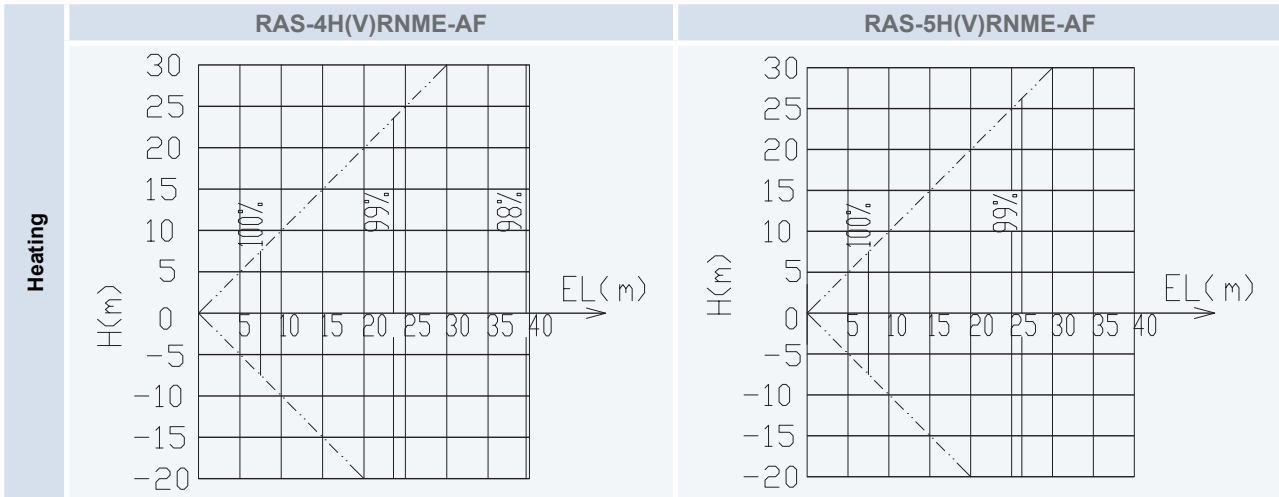

**i** NOTE

The heating capacity should be corrected according to the following formula:

$$THA = TH \times PH$$

THA: Actual corrected heating capacity (kW)

TH: Heating capacity from heating capacity table (kW).

PH: Heating piping length correction factor (in %).

# 5. Acoustic characteristic curves

## Index

5.1. Sound pressure level for outdoor unit .....	80
5.1.1. Considerations.....	80
5.1.2. Charts.....	81

## 5.1 Sound pressure level for outdoor unit

### 5.1.1 Considerations

- 1 Distance of the unit from the measuring point: At 1 meter from the unit's front surface; 1,5 meter from floor level.

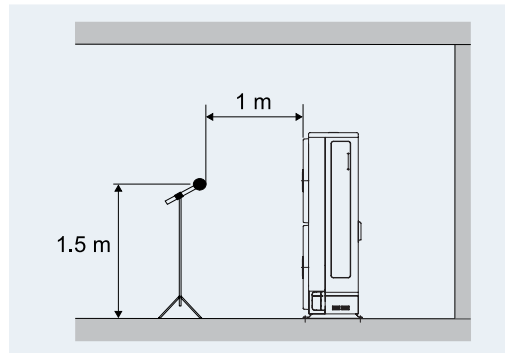

- 2 The data is measured in an anechoic chamber, so reflected sound should be taken into consideration when installing the unit.
- 3 The sound measured with the curve A shown in dB(A) represents the attenuation in function of frequency as perceived by the human ear.
- 4 Reference acoustic pressure 0dB=20μPa



**5.1.2 Charts**

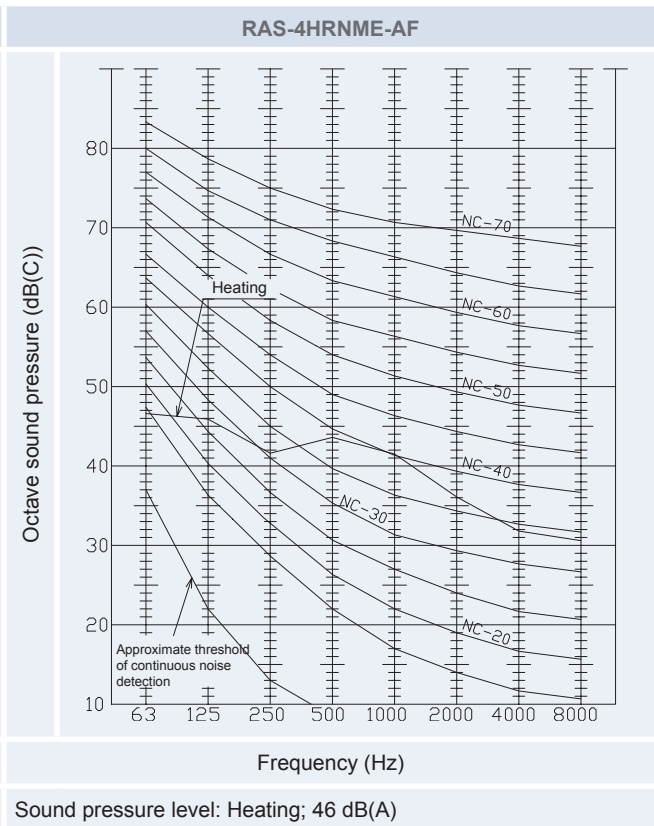
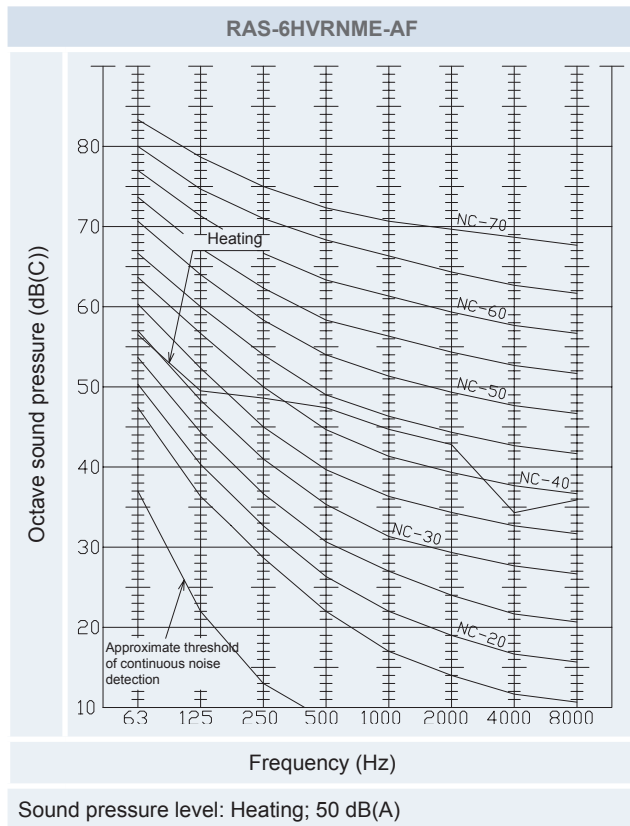
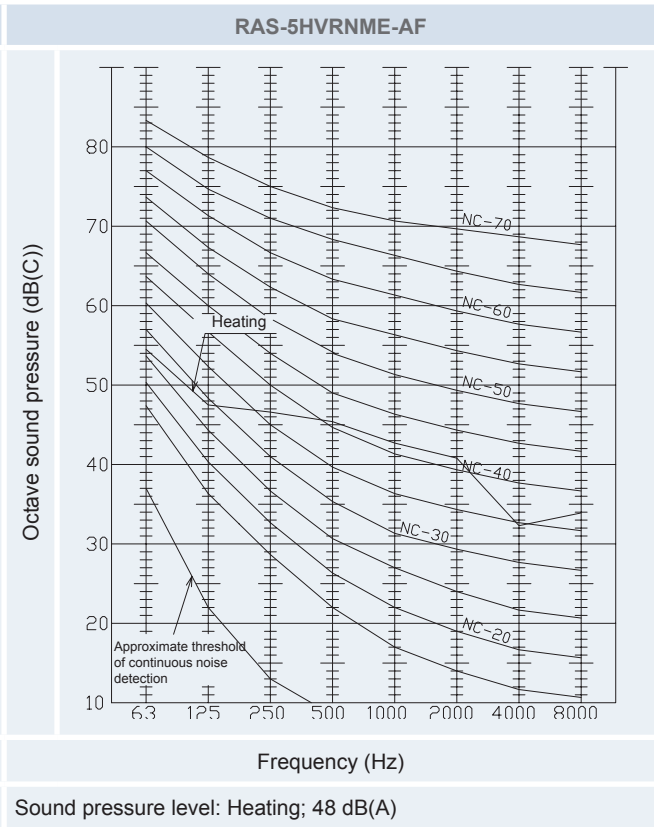
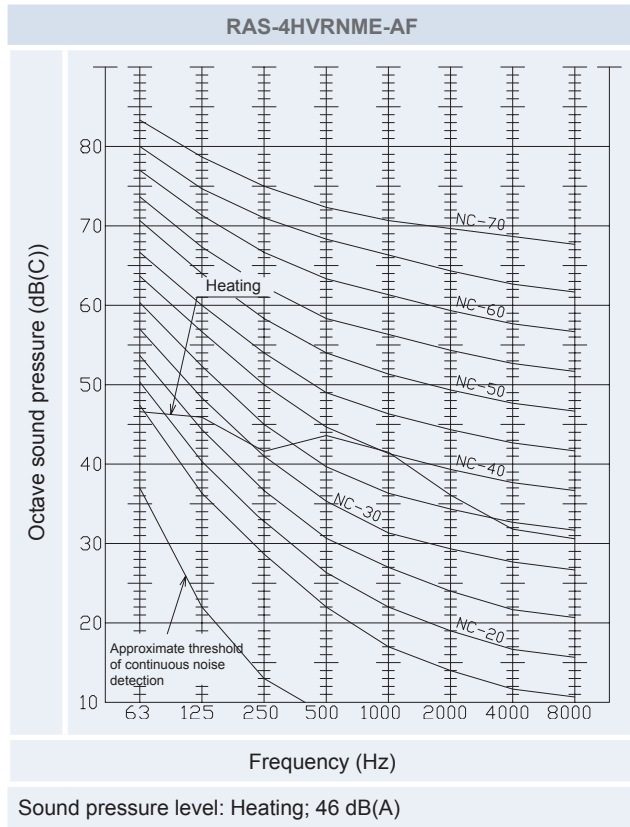

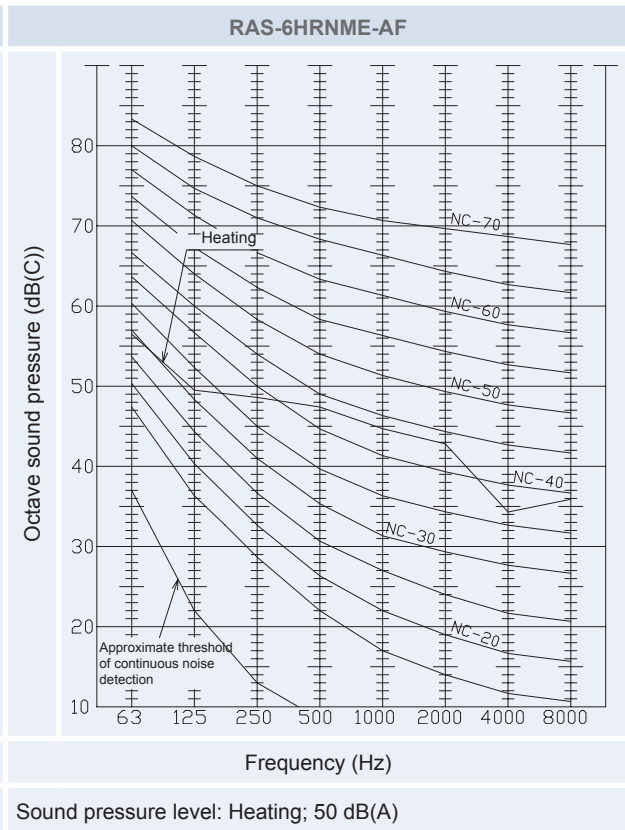
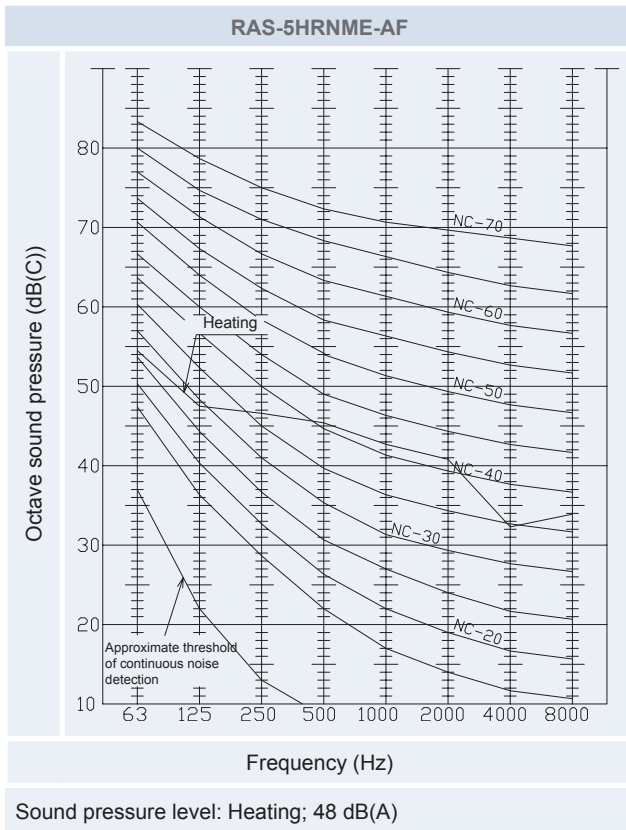

# 6. Working range

## Index

6.1. Working range ..... 84

## 6.1 Working range

Model		RWH-4.0FS(V)NFE	RWH-5.0FS(V)NFE	RWH-6.0FS(V)NFE
Water temperature	°C	Refer to the graphics for each case		
Minimum flow rate	m <sup>3</sup> /h	1.0	1.1	1.1
Maximum flow rate	m <sup>3</sup> /h	2.9	3.1	3.1
Minimum installation water volume	l	40	50	50
Minimum allowable water pressure	MPa	0.1		
Maximum allowable water pressure	MPa	0.3		
Indoor temperature installation	°C	5 ~ 35		

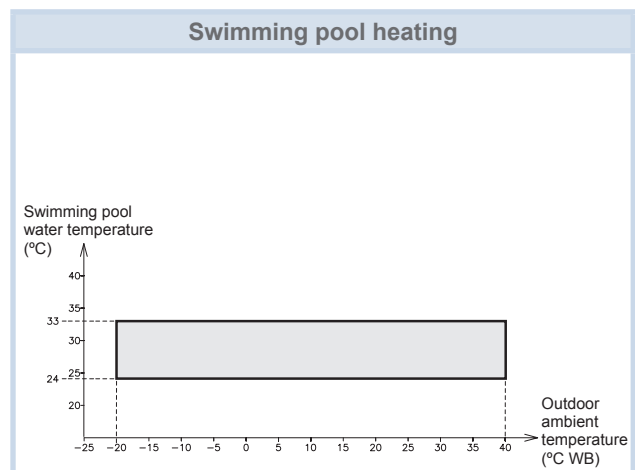
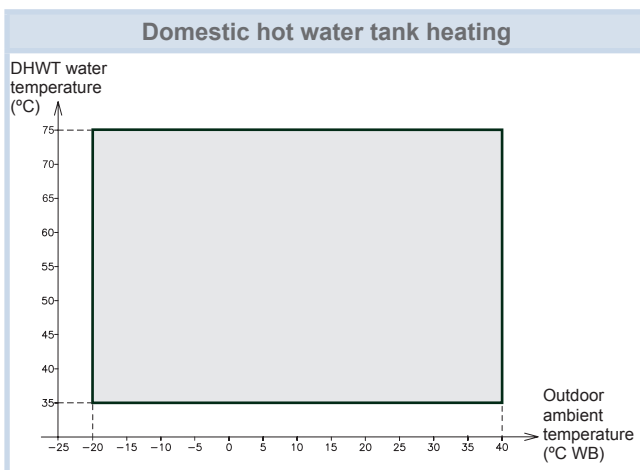
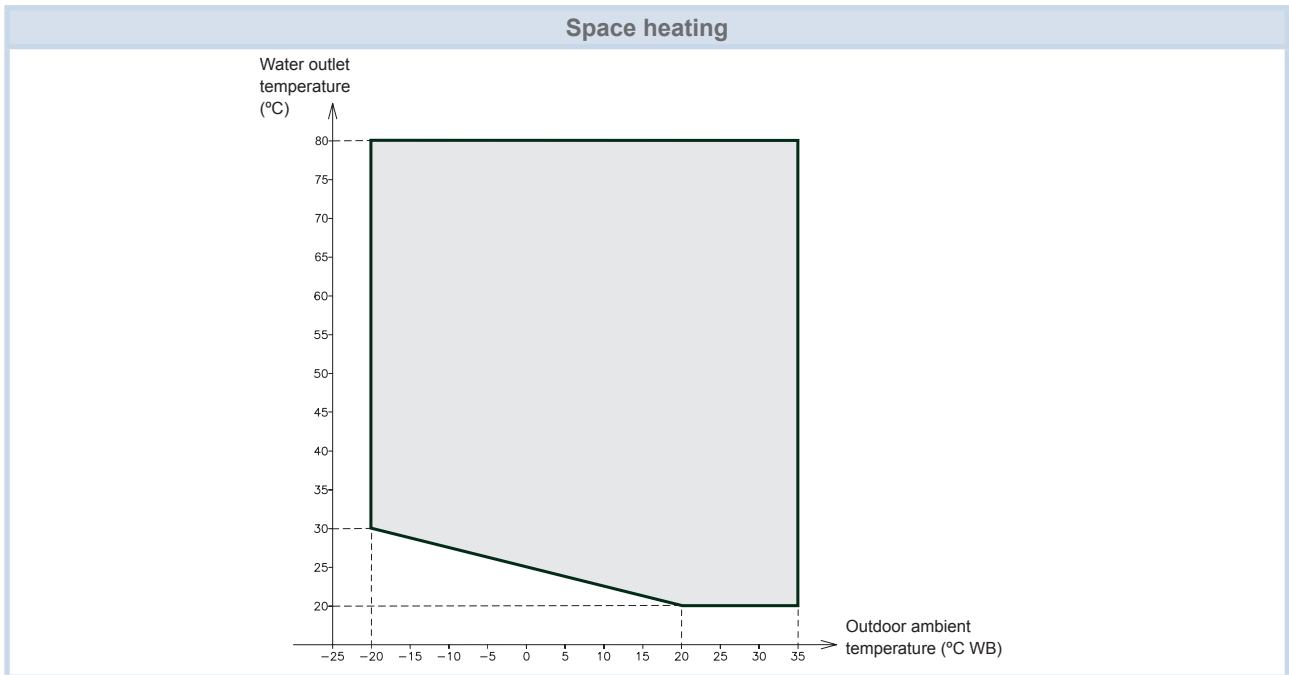

# 7. General dimensions

## Index

7.1. Name of parts.....	86
7.1.1. Outdoor unit.....	86
7.1.2. Indoor unit.....	87
7.1.3. Domestic Hot Water Tank.....	88
7.2. Dimensional data.....	89
7.2.1. Outdoor unit.....	89
7.2.2. Indoor unit and domestic hot water tank (optional).....	89
7.3. Service space.....	91
7.3.1. Outdoor unit.....	91
7.3.2. Indoor unit and domestic hot water tank (optional).....	92

## 7.1 Name of parts

### 7.1.1 Outdoor unit

#### ◆ RAS-(4-6)H(V)RNME-AF

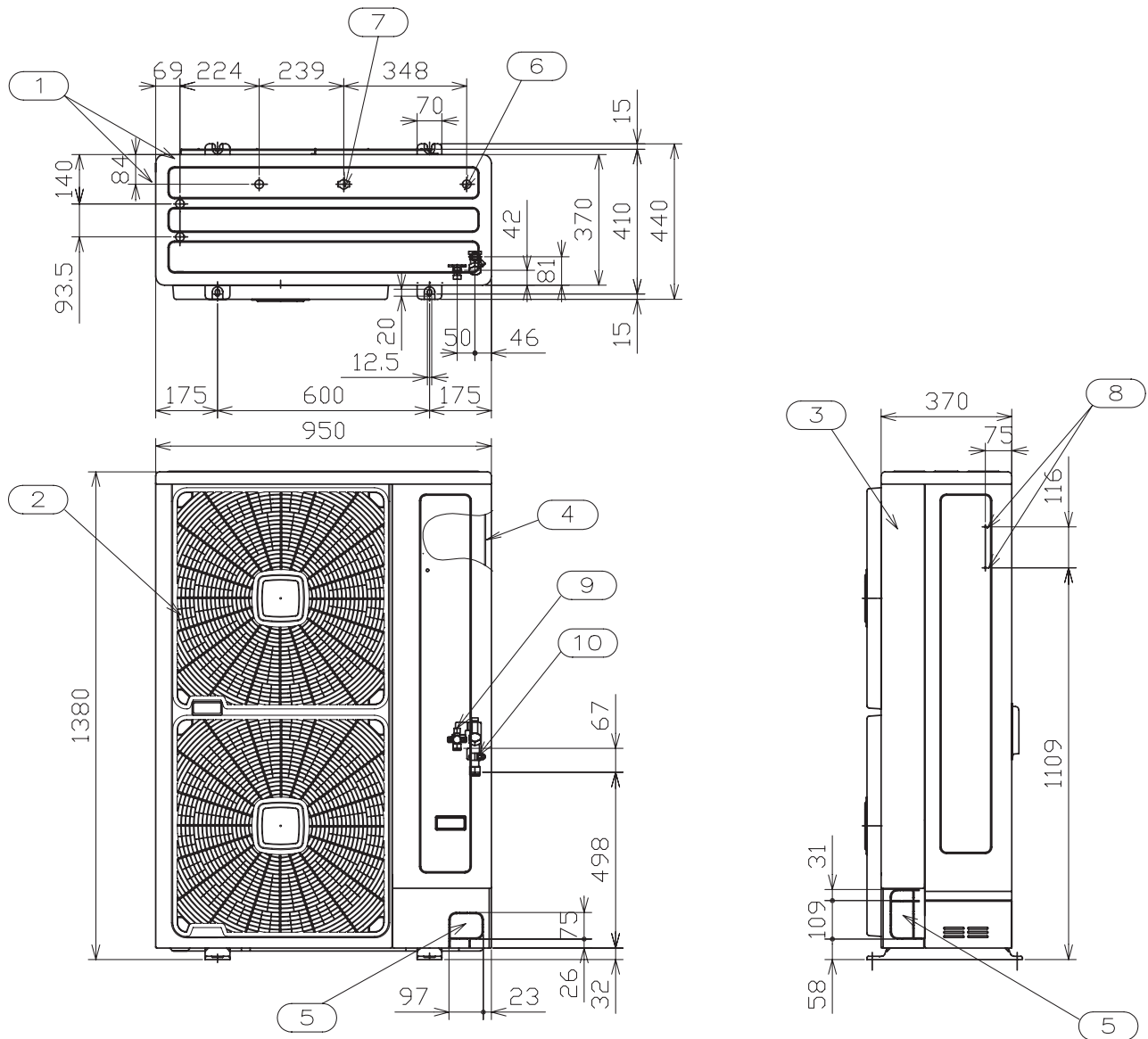

Units in: mm

No.	Part name	Remarks
1	Air intake	-
2	Air outlet	-
3	Service cover	-
4	Electrical switch box	-
5	Holes for refrigerant piping and electrical wiring piping	-
6	Drain holes	3-Ø24
7	Drain holes	2-Ø26
8	Holes for fixing machine to wall	4-(M5)
9	Refrigerant liquid pipe	Flare nut: Ø9.53 (3/8")
10	Refrigerant gas pipe	Flare nut: Ø15.88 (5/8")



**7.1.2 Indoor unit**

◆ **RWH-(4.0-6.0)FS(V)NFE**

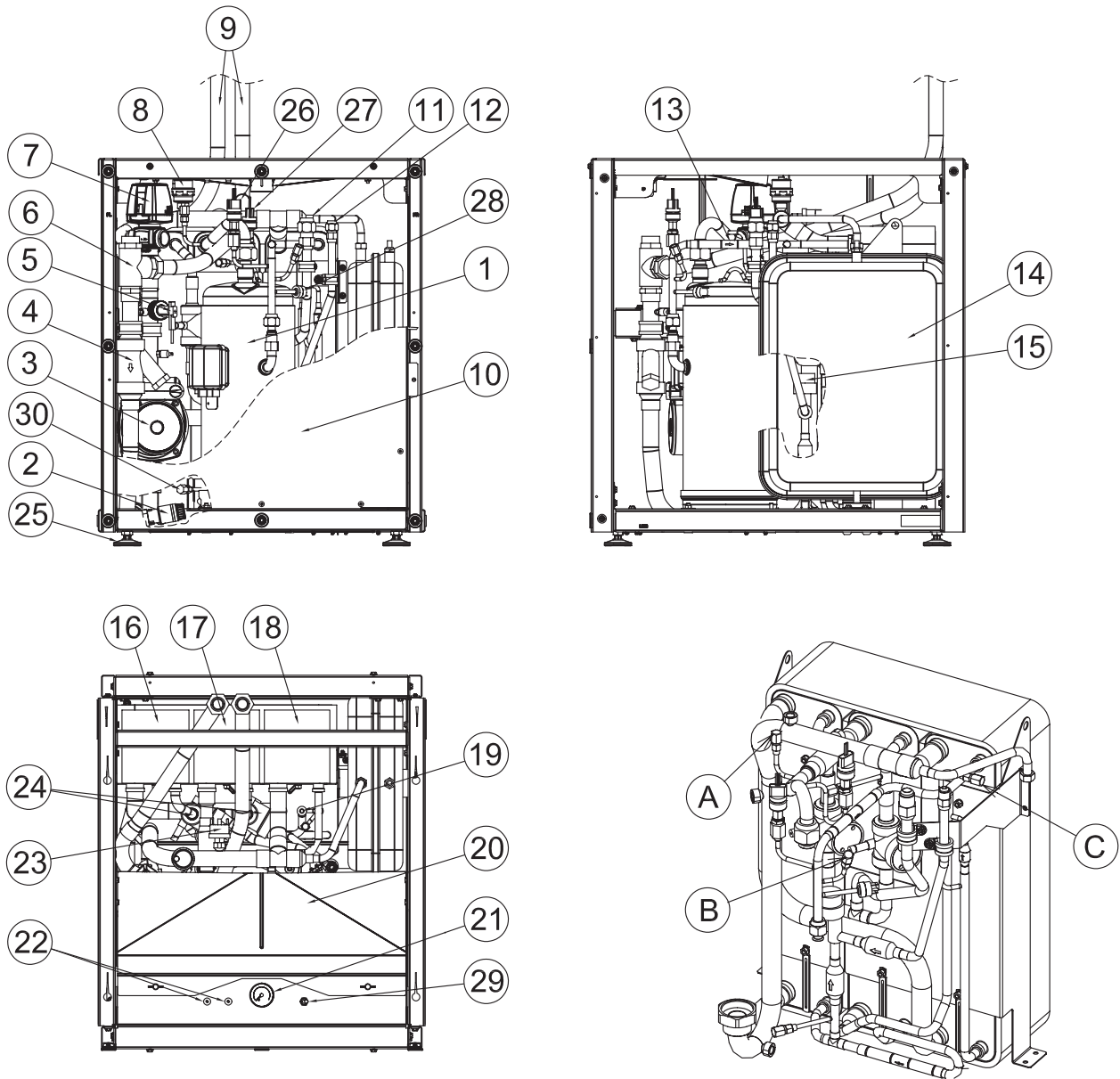

7

No.	Part name	No.	Part name	No.	Part name
1	Compressor	12	Liquid refrigerant pipe connection (ø9.53)	23	Water pressure switch
2	Safety valve	13	Check valve	24	Solenoid valves (SV1, SV2)
3	Water pump	14	Expansion vessel	25	Mounting foot (x4)
4	Water strainer	15	Expansion valve (1st cycle)	26	High pressure sensor (Pd)
5	Water flow switch	16	Plate heat exchanger (R410A-H2O)	27	Low pressure sensor (Ps)
6	T-branch	17	Plate heat exchanger (R410A-R134a)	28	High pressure switch (PSH)
7	3-way valve	18	Plate heat exchanger (R134a-H2O)	29	Switch for DHW emergency operation
8	Air purger	19	Expansion valve (2nd cycle)	A	R-134a check joint (for suction pressure measuring or vacuum operation)
9	Flexible water pipes for space heating (factory supplied accessory)	20	Upper cover for protection	B	R-134a check joint (for discharge pressure measuring or vacuum operation)
10	Electrical box	21	Manometer	C	R-134a check joint (for charge/removing refrigerant or vacuum operation)
11	Gas refrigerant pipe connection (ø15.88)	22	Water pressure ports (G 3/8")		

**7.1.3 Domestic Hot Water Tank**

◆ **DHWS-(190/255)S-2.0H1E**

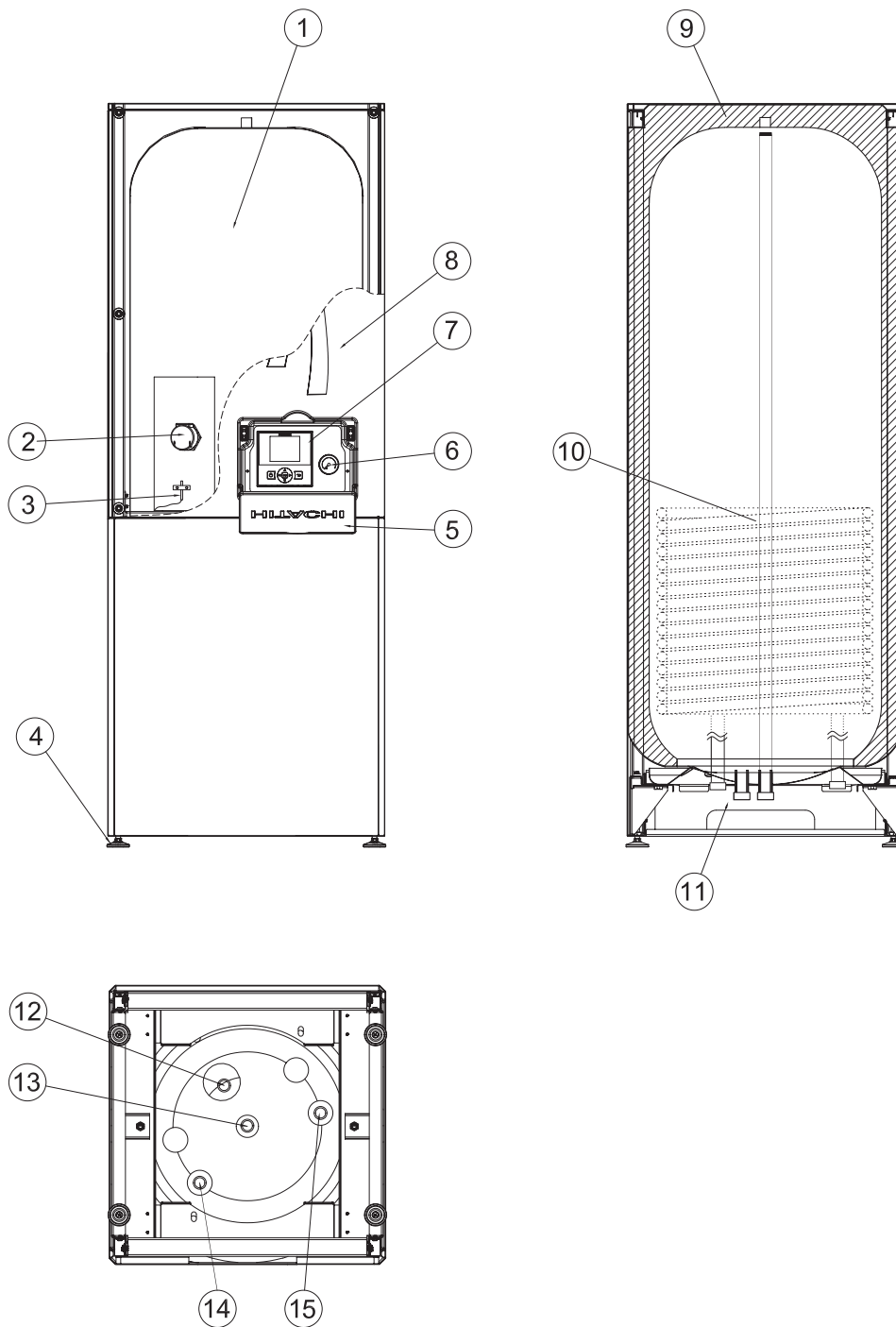

No.	Part name
1	Domestic hot water tank
2	Heater + thermostat
3	Sensor
4	Mounting foot (x4)
5	LCD controller cover

No.	Part name
6	Manometer
7	LCD controller
8	Front cover
9	Insulation
10	Heating coil

No.	Part name
11	Service access
12	DHW inlet connection (3/4" male)
13	DHW outlet connection (3/4" male)
14	Heating coil inlet connection (3/4" male)
15	Heating coil outlet connection (3/4" male)



## 7.2 Dimensional data

### **i** NOTE

All dimensions in mm.

#### 7.2.1 Outdoor unit

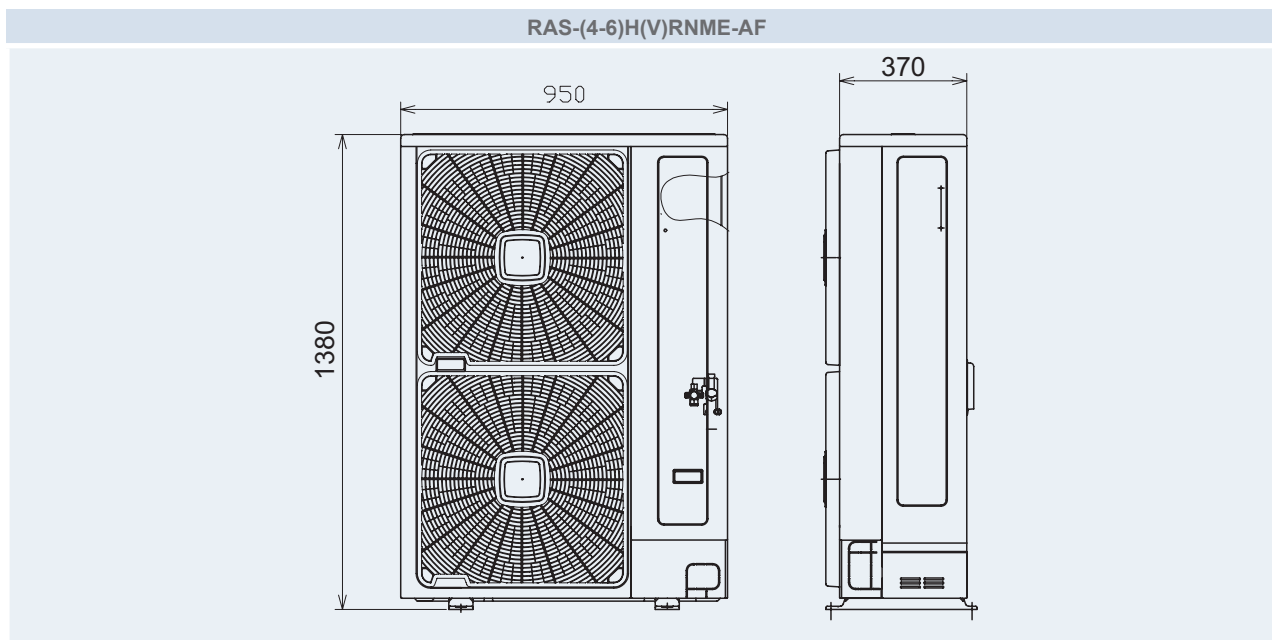

#### 7.2.2 Indoor unit and domestic hot water tank (optional)

### **i** NOTE

Height dimensions are shown with the minimum mounting foot height. These values can be adjusted up to +30 mm.

#### ◆ Indoor unit alone (without tank)

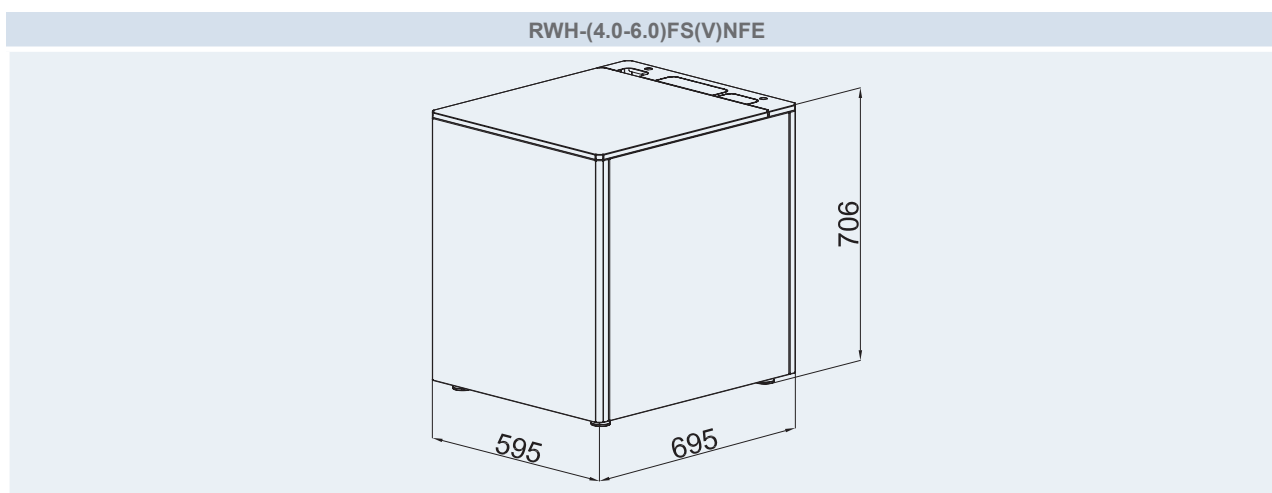

◆ Indoor unit with HITACHI tank (Tank integrated over the indoor unit)

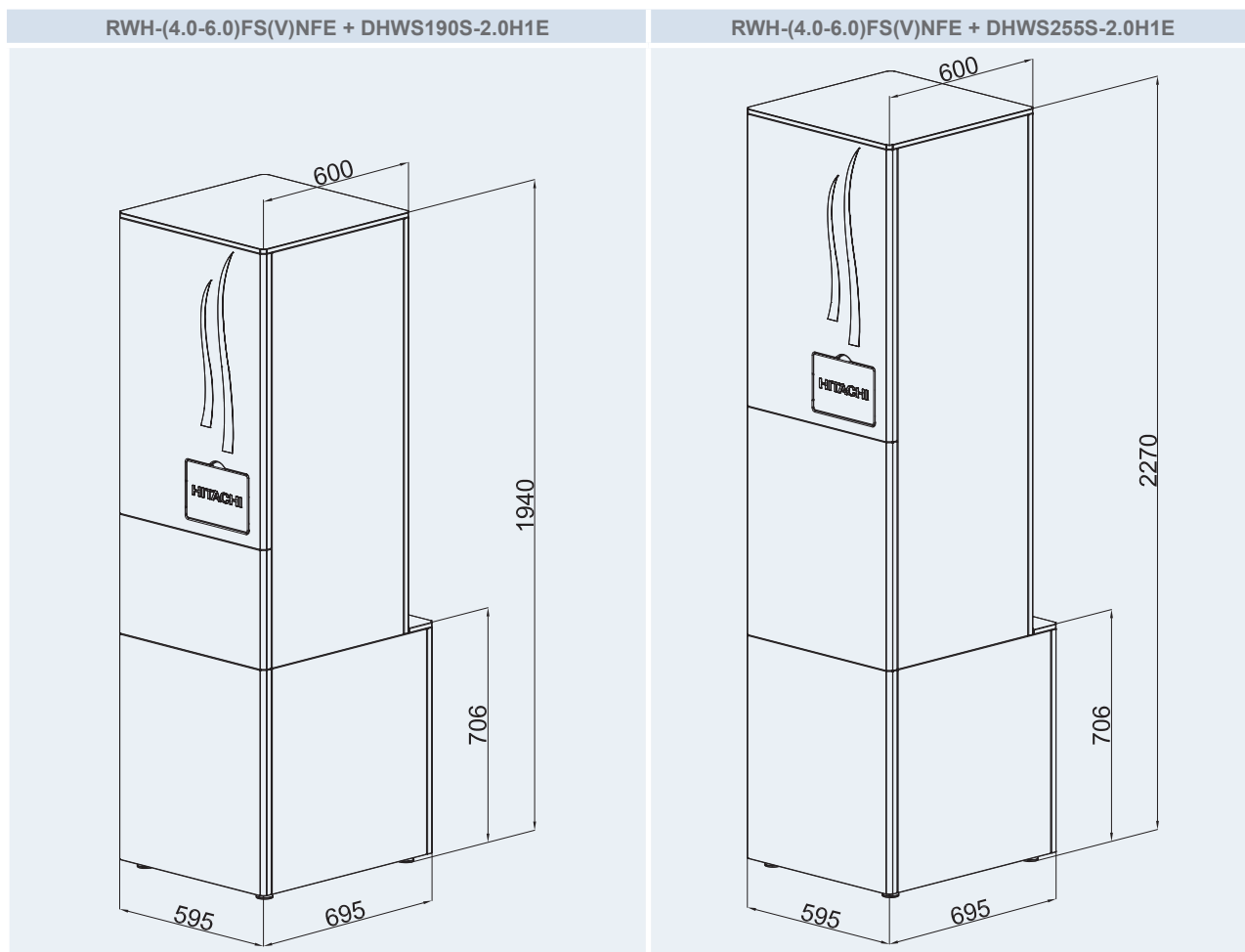

◆ Indoor unit with HITACHI tank (Tank beside the indoor unit)

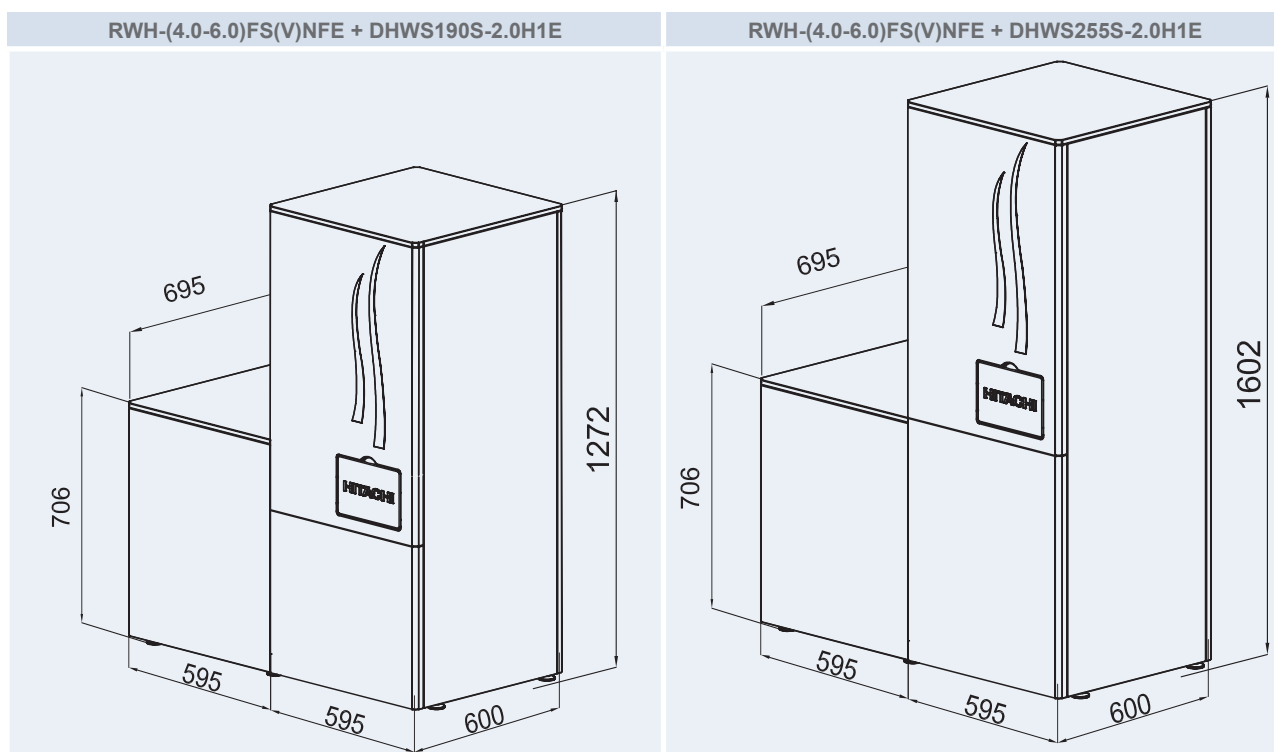

### 7.3 Service space

With the aim to assign the correct space for the unit servicing, it must be taken into account the minimum distances allowed. Depending on the position which the service will be done, it could be required different spaces.

#### 7.3.1 Outdoor unit

##### ◆ RAS-(4-6)H(V)RNME-AF

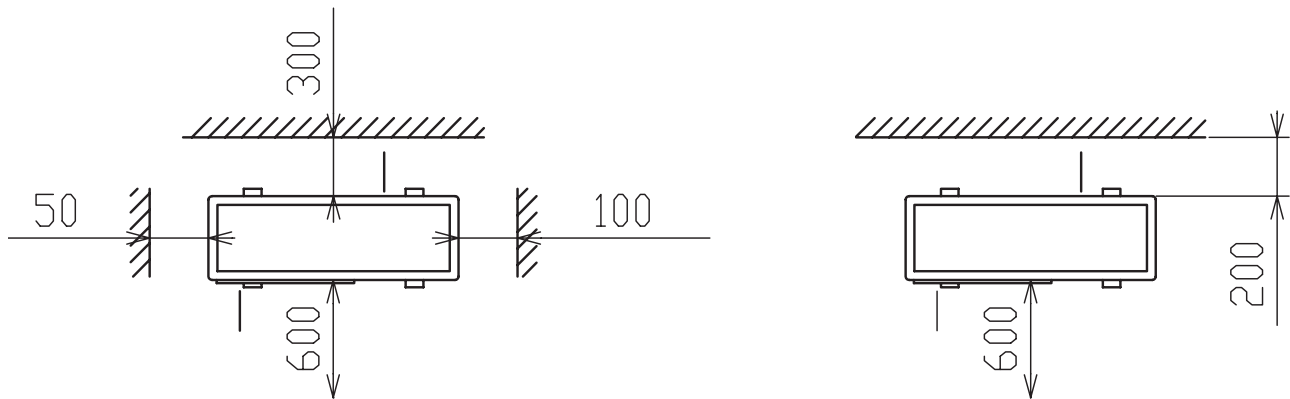

#### **i** NOTE

*For the specific information, please refer to Service Manual.*

**7.3.2 Indoor unit and domestic hot water tank (optional)**

◆ **Indoor unit alone (Without tank)**

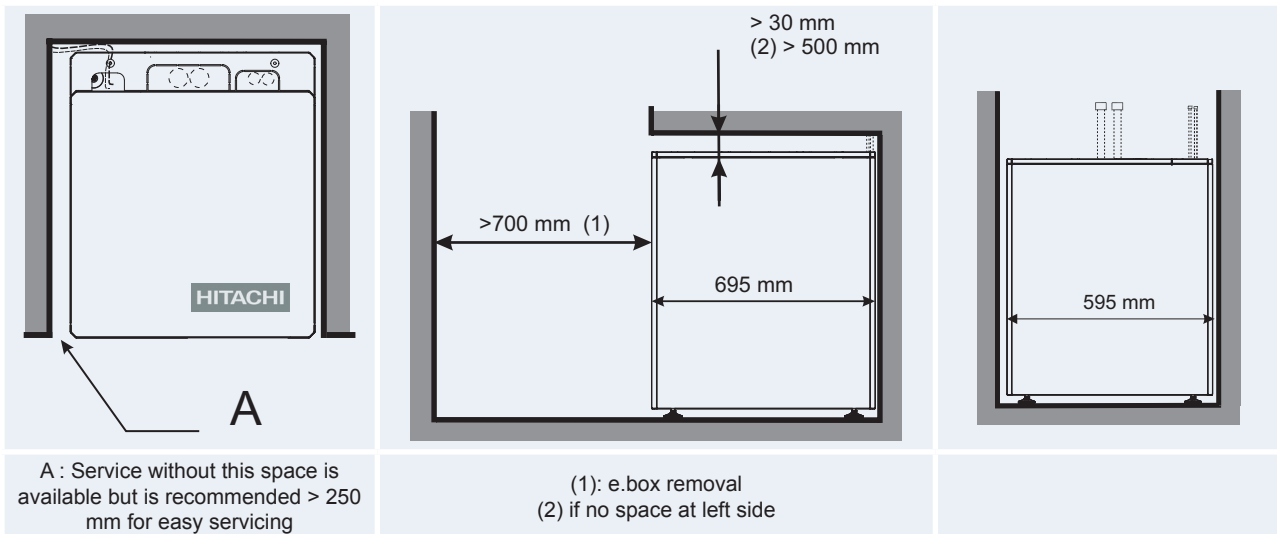

◆ **Indoor unit with HITACHI tank (Tank integrated over the indoor unit)**

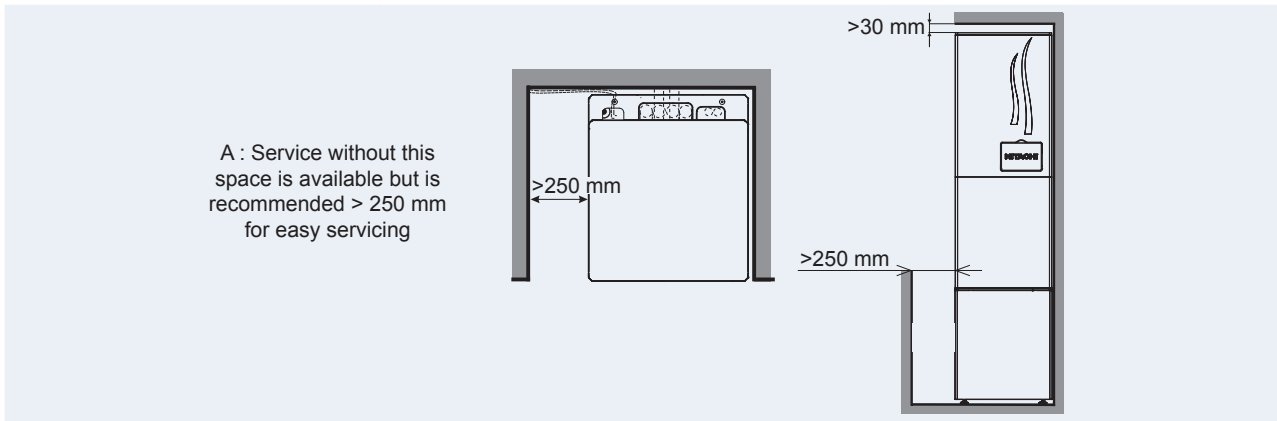
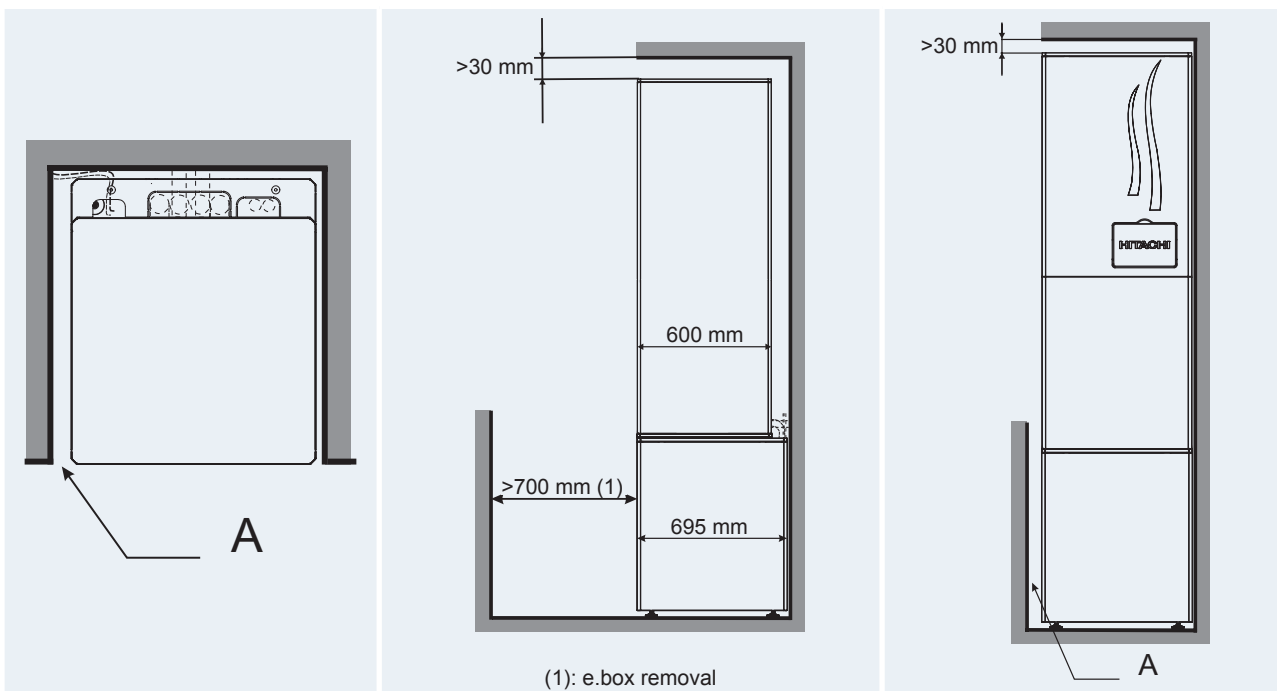

NOTE: If there is no space at left and right side, could be necessary to disassemble the tank or the indoor units for some special servicing (for example change the heat exchangers, etc)

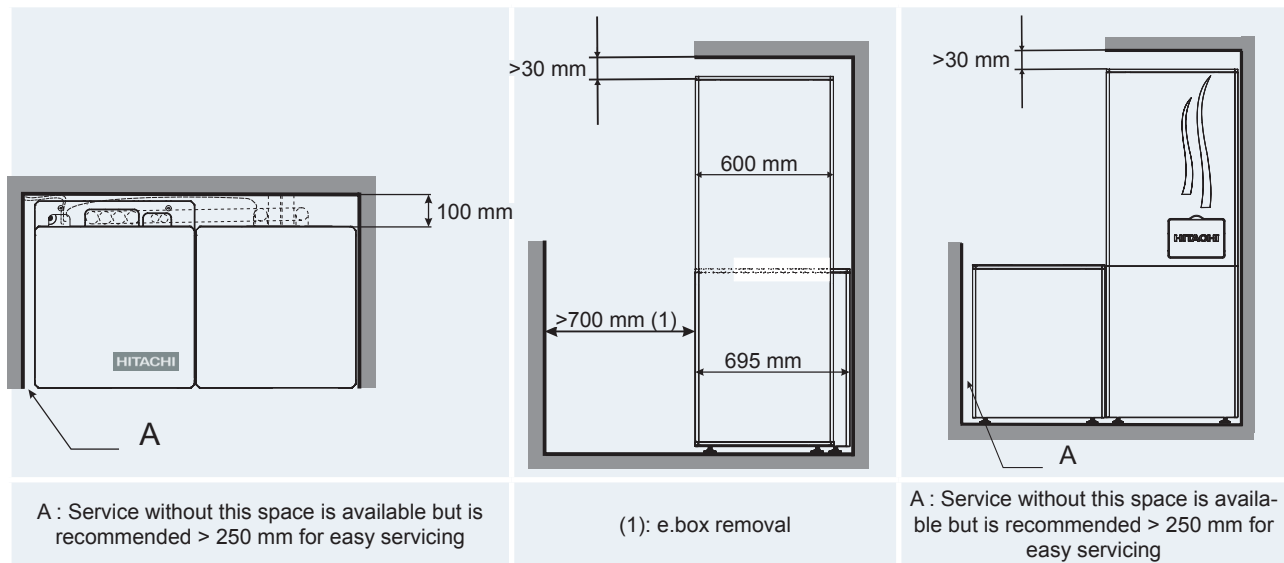
**◆ Indoor unit with HITACHI tank (Tank beside the indoor unit)**

**◆ Indoor unit with other tank (Non HITACHI tank beside the indoor unit)**

For Indoor unit service space, refer to the section: Indoor unit alone (Without tank).

For non HITACHI tank, see his own technical documentation.

**NOTE**

*The LCD controller (PC-S80TE) it is necessary.*



---

# 8. Refrigerant cycle and hydraulic circuit

---

## Index

8.1. RAS-(4-6)H(V)RNME-AF + RWH-(4.0-6.0)FS(V)NFE combination ..... 96

### 8.1 RAS-(4-6)H(V)RNME-AF + RWH-(4.0-6.0)FS(V)NFE combination

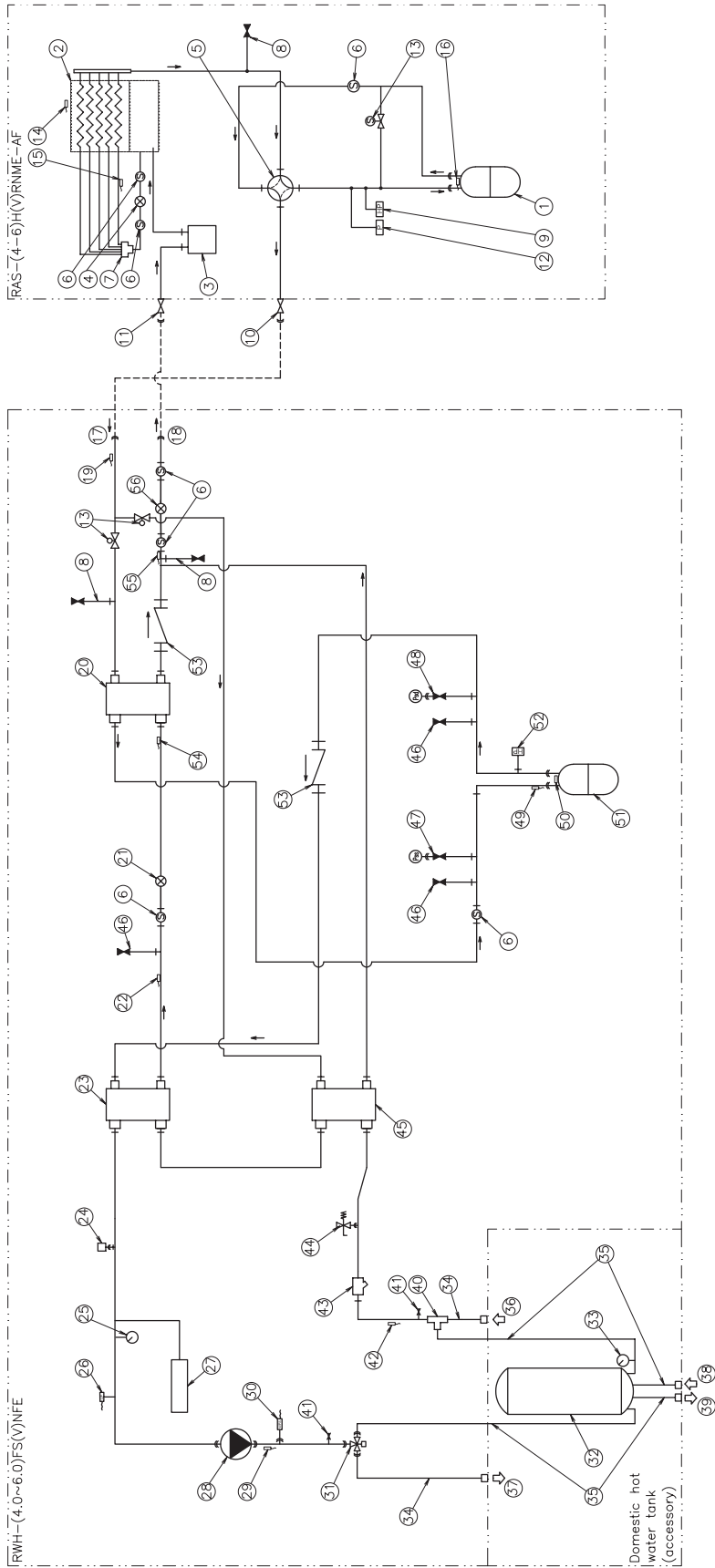

Heating refrigerant flow		Water flow		Field supplied piping line		Flare Nut connection		Brazed connection		Refrigerant 1:		Refrigerant 2:	
No.	Part name	No.	Part name	No.	Part name	No.	Part name	No.	Part name	No.	Part name	No.	Part name
1	Outdoor unit compressor	13	Solenoid valve	25	Indoor unit manometer	37	Water outlet connection (1")	49	IU compressor suction thermistor				
2	Outdoor unit heat exchanger	14	Ambient thermistor	26	Water pressure switch	38	DHW inlet connection (3/4")	50	IU compressor discharge thermistor				
3	Liquid tank	15	Evaporator pipe thermistor	27	Expansion vessel	39	DHW outlet connection (3/4")	51	Indoor unit compressor				
4	Outdoor unit expansion valve	16	OU compressor discharge thermistor	28	Water pump	40	T-branch	52	IU high pressure switch (protection)				
5	Reversing valve	17	Refrigerant gas connection	29	Water outlet thermistor	41	Water pressure port (G 3/8")	53	Check valve				
6	Strainer	18	Refrigerant liquid connection	30	Water flow switch	42	Water inlet thermistor	54	Evaporating heating thermistor				
7	Distributor	19	Gas pipe thermistor	31	3-way valve	43	Water strainer	55	Liquid pipe thermistor				
8	R410A check joint (1/2")	20	Plate heat exchanger (R410A-R134a)	32	Domestic hot water tank	44	Safety valve	56	Indoor unit expansion valve (1st cycle)				
9	OU high pressure switch (protection)	21	Indoor unit expansion valve (2nd cycle)	33	DHWT manometer	45	Plate heat exchanger (R410A-H2O)						
10	Gas pipe stop valve	22	Evaporating cooling thermistor	34	Flexible water pipe (1")	46	R134a check joint (7/16")						
11	Liquid pipe stop valve	23	Plate heat exchanger (R134a-H2O)	35	Flexible water pipe (3/4")	47	Low pressure sensor (Ps)						
12	Pressure switch (control)	24	Air purger	36	Water inlet connection (1")	48	High pressure sensor (Pd)						



# 9. Refrigerant and water piping

## Index

9.1. Refrigerant circuit .....	98
9.1.1. Refrigerant piping .....	98
9.1.2. Piping connections .....	99
9.1.3. Refrigerant charge amount .....	100
9.1.4. Precautions in the event of gas refrigerant leaks .....	100
9.1.5. Pump down of refrigerant .....	102
9.1.6. Refrigerant check joints .....	102
9.2. Space heating hydraulic circuit.....	103
9.2.1. Hydraulic circuit .....	103
9.2.2. Water piping.....	104
9.2.3. Water quality.....	105
9.2.4. Water flow adjustment .....	105
9.2.5. Pressure charts .....	107
9.3. Domestic Hot Water hydraulic circuit (Optional).....	108
9.3.1. Hydraulic circuit .....	108
9.3.2. Water piping.....	110
9.3.3. Water quality.....	112

## 9.1 Refrigerant circuit

### 9.1.1 Refrigerant piping

#### ◆ Refrigerant piping length between indoor unit and outdoor unit

The refrigerant piping length between indoor unit and outdoor unit should be designed using the following chart.

Keep the design point within the area of the chart, which is showing the applicable height difference according to piping length.

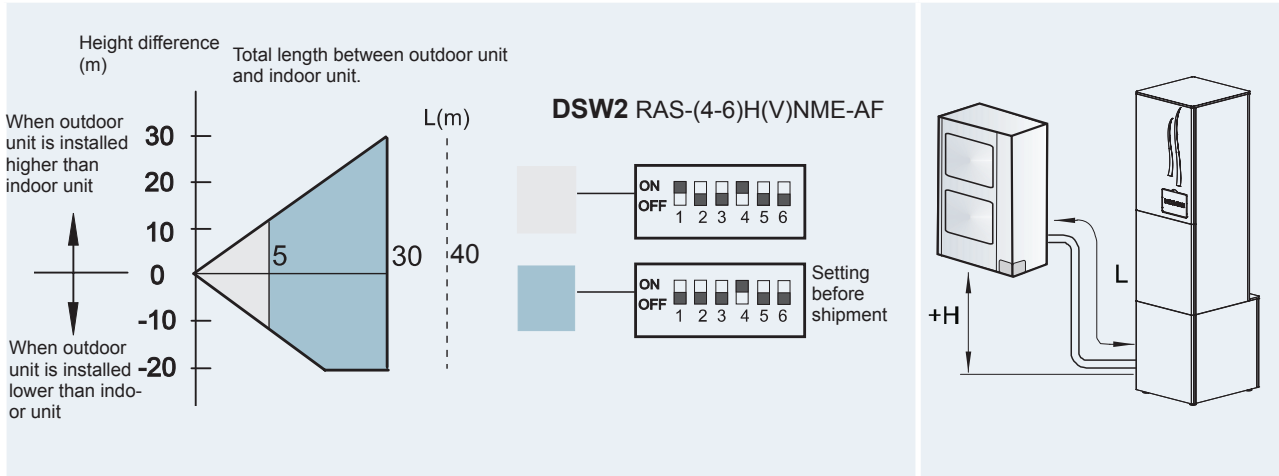

Item		(4-6)HP
Maximum piping length between outdoor unit and indoor unit (Lmax)	Actual piping length	30 m
	Equivalent piping length	40 m
Minimum piping length between outdoor unit and indoor unit (Lmin)	Actual piping length	3 m
Maximum height difference between indoor and outdoor unit (H)	Outdoor unit higher than indoor unit	30 m
	Indoor unit higher than outdoor unit	20 m

#### ◆ Refrigerant piping size

Piping connection size of outdoor unit & indoor unit

Outdoor unit	Pipe size		Indoor Unit	Pipe size (*)	
	Gas pipe	Liquid pipe		Gas pipe	Liquid pipe
RAS-4H(V)RNME-AF	Ø 15.88 (5/8")	Ø 9.53 (3/8")	RWH-4.0FS(V)NFE	Ø 15.88 (5/8")	Ø 9.53 (3/8")
RAS-5H(V)RNME-AF	Ø 15.88 (5/8")	Ø 9.53 (3/8")	RWH-5.0FS(V)NFE	Ø 15.88 (5/8")	Ø 9.53 (3/8")
RAS-6H(V)RNME-AF	Ø 15.88 (5/8")	Ø 9.53 (3/8")	RWH-6.0FS(V)NFE	Ø 15.88 (5/8")	Ø 9.53 (3/8")

#### **i** NOTE

(\*) Refrigerant liquid / gas piping accessory is factory supplied.

### 9.1.2 Piping connections

#### ◆ Outdoor unit

Refrigerant gas/liquid connection (R410A) of indoor unit are located where it is visible in the following image:

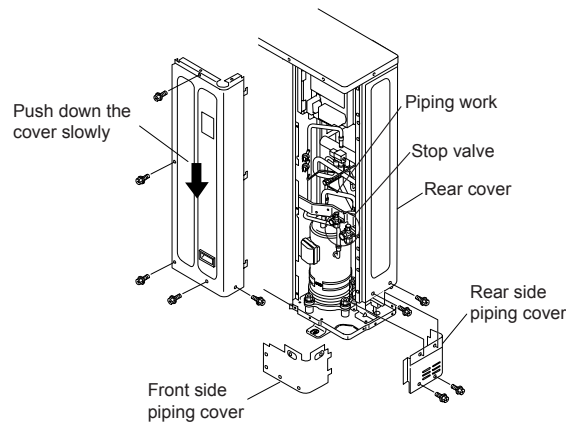

#### ◆ Indoor unit

#### Refrigerant gas and liquid pipe indoor unit connection

Refrigerant gas/liquid connection (R410A) of indoor unit are located where it is visible in the following images:

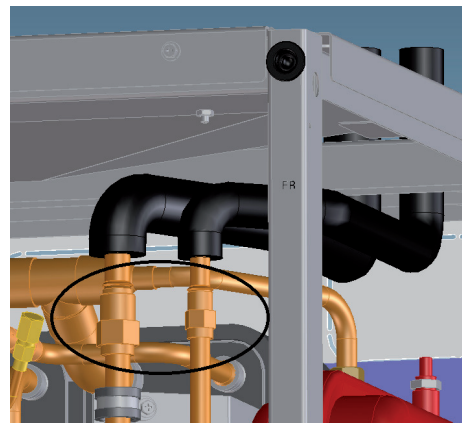
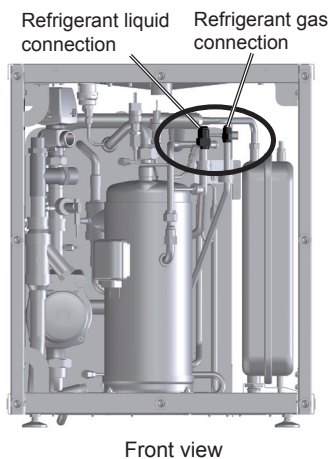

#### **i** NOTE

*The refrigerant gas/liquid connection (R410A) of indoor unit is a flare nut connection but after installing the piping accessories the connection is done by brazing.*

#### Refrigerant liquid/gas piping connection accessories

It is provided an accessory for the connection between the field refrigerant pipes (outdoor unit) and the indoor unit.



#### **i** NOTE

*Refer to the indoor unit [Installation and operation manual](#) for the accessory installation.*

### 9.1.3 Refrigerant charge

The YUTAKI S80 has two refrigerant circuits. The R410A circuit (1st cycle) works with this refrigerant while the indoor circuit (2nd cycle) works with R134a refrigerant. Piping connections must be performed in the R410A cycle between the outdoor unit and the indoor unit.

#### ◆ Refrigerant charge amount

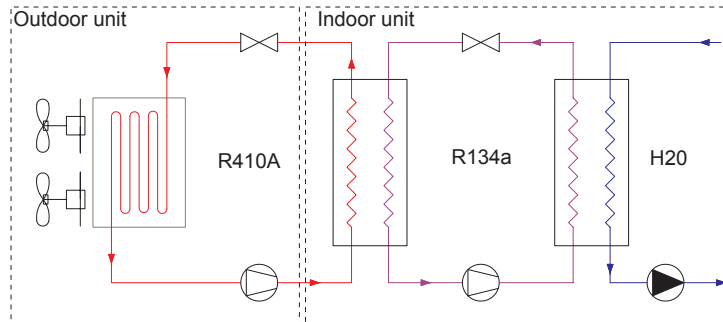

- The 1st cycle (R410A) is factory charged with a refrigerant charge amount for 30m of piping length. The maximum refrigerant piping length is 30m so it is not required an additional refrigerant charge.
- The 2nd cycle (R134a) connections are factory installed and refrigerant charged so no piping work or refrigerant charge is needed.

#### **i** NOTE

- **Refer to the outdoor unit *Installation and operation manual* to charge the R410A refrigerant inside the indoor unit.**
- **Supply power to the indoor unit and switch the DSW1-2 ON of its PCB1. Thereby the indoor unit SV1 and SV2 open to allow the vacuum and refrigerant charge operation inside the indoor unit. Very important to remind to switch the DSW1-2 OFF when finishing the whole procedure.**

#### ◆ Refrigerant charge before shipment ( $W_0$ (kg))

Unit type	Unit model	$W_0$ (kg) R410A	$W_0$ (kg) R134a
Outdoor unit	RAS-4H(V)RNME-AF	3.9	-
	RAS-(5/6)H(V)RNME-AF	4.0	-
Indoor unit	RWH-(4-6)FS(V)NFE	-	2.5

### 9.1.4 Precautions in the event of gas refrigerant leaks

The installers and those responsible for drafting the specifications are obliged to comply with local safety codes and regulations in the case of refrigerant leakage.

#### **!** CAUTION

- **Check for refrigerant leakage in detail. If a large refrigerant leakage occurred, it would cause difficulty with breathing or harmful gases would occur if a fire were in the room.**
- **If the flare nut is tightened too hard, it may crack over time and cause refrigerant leakage.**

◆ **Maximum permitted concentration of HFCs**

The refrigerant R410A, charged in the outdoor unit, and the refrigerant R134a, charged in the indoor unit, are incombustible and non-toxic gases. However, if leakage occurs and gas fills a room, it may cause suffocation.

The maximum permissible concentration of HFC gas according to EN378-1 is:

Refrigerant	Maximum permissible concentration (kg/m <sup>3</sup> )
R410A	0.44
R134a	0.25

The minimum volume of a closed room where the indoor unit is installed to avoid suffocation in case of leakage is:

Minimum volume	<b>V &gt; 10 m<sup>3</sup></b>
----------------	--------------------------------

If the room volume is below the minimum value, some effective measure must be taken account after installing to prevent suffocation in case of leakage.

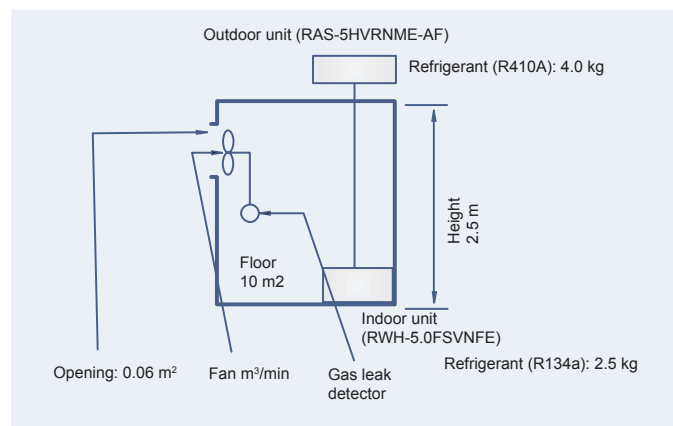

**Countermeasure in the event of possible refrigerant leakage**

The room must have the following features to prevent suffocation in case a refrigerant leakage occurs:

- 1 Provide a shutterless opening which will allow fresh air to circulate into the room.
- 2 Provide a doorless opening of 0.15% or more size to the floor area.
- 3 There must be a ventilator fan connected to a gas leak detector, with a ventilator capacity of 0.4 m<sup>3</sup>/min or higher per Japanese refrigeration ton (= compressor displacement volume / (5.7 m<sup>3</sup>/h (R410A) or 14.4 m<sup>3</sup>/h (R134a)) of the air conditioning system using the refrigerant.

R410A	
Outdoor unit model	Tonnes
RAS-4H(V)RNME-AF	1.35
RAS-(5/6)H(V)RNME-AF	1.84

R134a	
Indoor unit model	Tonnes
RWH-(4.0-6.0)FS(V)NFE	1.61

**i NOTE**

**Always take the maximum value between the R410A and R134a.**

- 4 Pay special attention to the place, such as a basement, etc., where the refrigerant can stay, since refrigerant is heavier than air.

### 9.1.5 Pump down of refrigerant

#### ◆ 1st cycle (R410A)

#### ⚠ CAUTION

- To pump down the refrigerant of the R410A cycle (1st cycle) it must be done through the outdoor unit. Refer to the outdoor unit *Installation and operation manual* for the procedure.
- To pump down the R410A refrigerant from the indoor unit, supply power to it.
- In case outdoor unit test run failure (compressor failure, etc.), switch the DSW1-2 ON of indoor unit PCB1. Thereby the indoor unit SV1 and SV2 open and allow the R410A refrigerant inside the indoor unit to flow to be collected from the outdoor unit side. Switch the DSW1-2 OFF when finishing the procedure.

#### ◆ 2nd cycle (R134a)

#### ⚠ CAUTION

The 2nd cycle (R134a) connections are factory installed and refrigerant charged so no vacuum or pumping down work is needed.

### 9.1.6 Refrigerant check joints

**1st cycle (R410A) Outdoor unit**

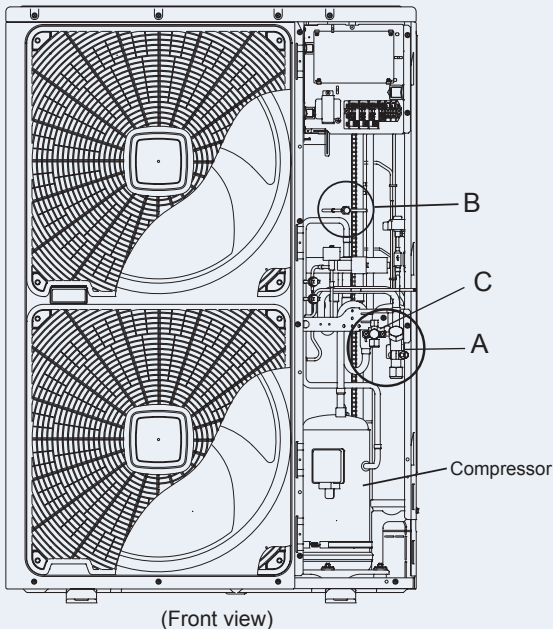

Part name	Function
Check joint for gas stop valve "A"	High pressure
Check joint for piping "B"	Exclusive for vacuum and pump down refrigerant
Check joint for liquid stop valve "C"	Low pressure

**2nd cycle (R134a) Indoor unit**

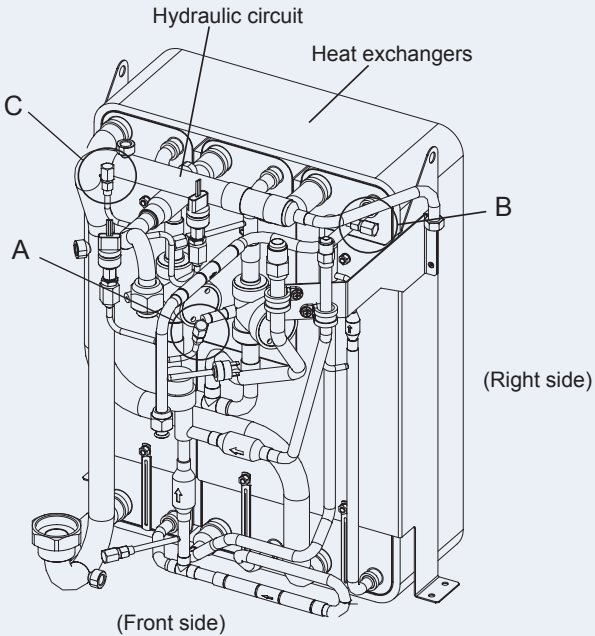

Part name	Function
Check joint for piping "A"	High pressure or vacuum
Check joint for piping "B"	Vacuum and pump down refrigerant
Check joint for piping "C"	Low pressure or vacuum

## 9.2 Space heating hydraulic circuit

### DANGER

**Do not connect the power supply to the indoor unit and DHW tank prior filling of water both circuits and checking water pressure and the total absence of any water leak.**

### NOTE

**The maximum piping length depends on the maximum pressure availability in the water outlet pipe. Please check the pump curves.**

### 9.2.1 Hydraulic circuit

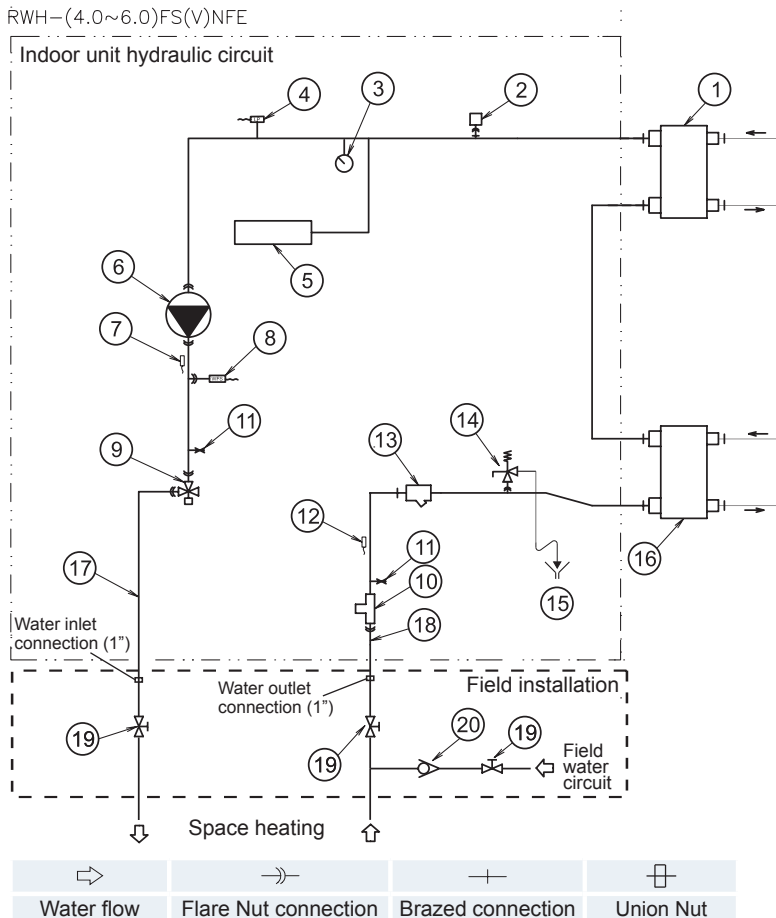

Nature	No.	Part name
Factory supplied	1	Plate heat exchanger (R134a-H2O)
	2	Air purger
	3	Indoor unit manometer
	4	Water pressure switch
	5	Expansion vessel
	6	Water pump
	7	Water outlet thermistor
	8	Water flow switch
	9	3-way valve
	10	T-branch
	11	Water pressure port (G 3/8")
	12	Water inlet thermistor
	13	Water strainer
	14	Safety valve
	15	Draining
	16	Plate heat exchanger (R410A-H2O)
	17	Space heating inlet water pipe (1") (accessory)
	18	Space heating outlet water pipe (1") (accessory)
Field supplied	19	Shut-off valve (field supplied)
Accessory	20	Water check valve (ATW-WCV-01 accessory)

9

#### ◆ Additional hydraulic necessary elements

The following hydraulic elements are necessary to correctly perform the space heating water circuit:

- 2 shut-off valves (field supplied) must be installed in the indoor unit. One at the water inlet connection and the other at the water outlet connection in order to make easier any maintenance work.
- 1 water check valve (ATW-WCV-01 accessory) with 1 shut-off valve (field supplied) must be connected to the water filling point when filling the indoor unit. The Check valve acts as a safety device to protect the installation against back pressure, back flow and back syphon of non-potable water into drinking water supply net.

### NOTE

**An additional special water filter is highly recommended to be installed on the space heating (field installation), in order to remove possible particles remaining from brazing which cannot be removed by the indoor unit water strainer.**

### 9.2.2 Water piping

#### ◆ Water pipes connection

Space heating water connection of indoor unit are located where it is visible in the following images:

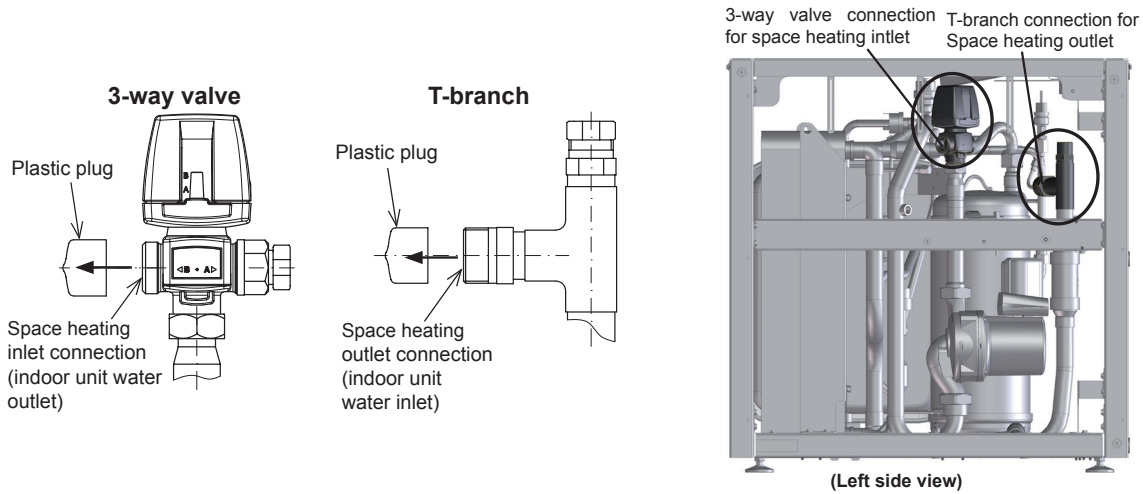

#### Piping size

(mm (inches))

	Space heating	
	3-way valve connection	T-branch connection
RWH-(4.0-6.0)FS(V)NFE	Ø25.4 (1")	Ø25.4 (1")

#### ◆ Space heating pipes (factory supplied)

Indoor unit is provided with two flexible water pipes (space heating pipes) for connection between the space heating and the indoor unit (to the T-branch and to the 3-way valve).

Item	Connection
<p>1385mm Ø25.4 (1")</p>	Space heating outlet pipe (Without elbow) For the connection between the T-branch water inlet and the space heating outlet.
<p>1035mm</p>	Space heating inlet pipe (With elbow) For the connection between the 3-way valve water outlet and the space heating inlet.

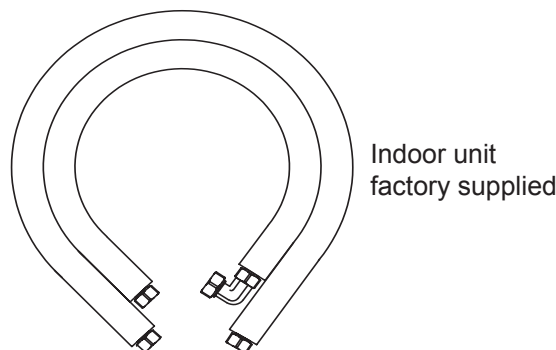

#### **i** NOTE

Please, refer to the *Installation and operation manual of the Domestic hot water tank of YUTAKI S80* for the detailed information.



### 9.2.3 Water quality

#### **⚠ CAUTION**

- **Water quality must be according to EU council directive 98/83 EC.**
- **Water should be subjected to filtration or to a softening treatment with chemicals before application as treated water.**
- **It is also necessary to analyse the quality of water by checking pH, electrical conductivity, ammonia ion content, sulphur content, and others. Should the results of the analysis be not good, the use of industrial water would be recommended.**
- **It is mandatory to do not add any kind of antifreeze product to the water circuit.**
- **To avoid deposits of scale on the heat exchangers surface it is mandatory to ensure a high water quality with low levels of  $\text{CaCO}_3$ .**

### 9.2.4 Water flow adjustment

In every installation the Circuit's water flow must be adjusted according to its particular internal Water pressure lost. In addition to this, the circuit should be set according to the Space heating (Heating Floor, Radiators, Fan Coils) and its corresponding water outlet temperature. The procedure for adjusting the water flow is described below:

- 1 Pressure lost calculation
- 2 Check the Pump Performance Curves
- 3 Selection of the Pump Speed
- 4 Water flow adjustment

Procedure:

- 1 Pressure lost calculation

The indoor unit is factory supplied with two Water Pressure Ports placed in the Upper front support. The object of these Water Pressure Ports, is to offer the installer a quick connection to read the Lost Pressure in the circuit when commissioning.

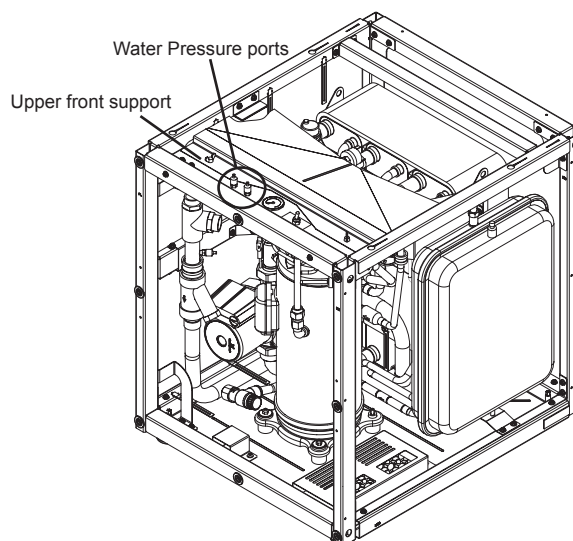

Plug in a differential Manometer to the Pressure Ports and open the inlet / outlet ports<sup>(1)</sup>.

The Pressure Lost is calculated from the pressure difference between the value of the inlet and the outlet water pressure.

#### **i NOTE**

<sup>(1)</sup> **If there is no having a Differential Manometer, it is possible to do this operation with just one std. Manometer (it is advisable to use the same Manometer in order to avoid reading mistakes from different devices because of different tolerances or adjustment).**

## 2 Check the pump performance curves

Refer to the Pump Performance Curves (see next chapter Pressure charts) to calculate the circuit's Water Flow depending on the actual Pressure Drop and the Space heating type (Heating Floor, Radiators, Fan Coils).

## 3 Selection of the pump speed

The indoor unit pump should be adjusted according to Pressure Lost of the circuits and the calculated Water Flow. The pump speed selector switch is located on the pump's Terminal Box.

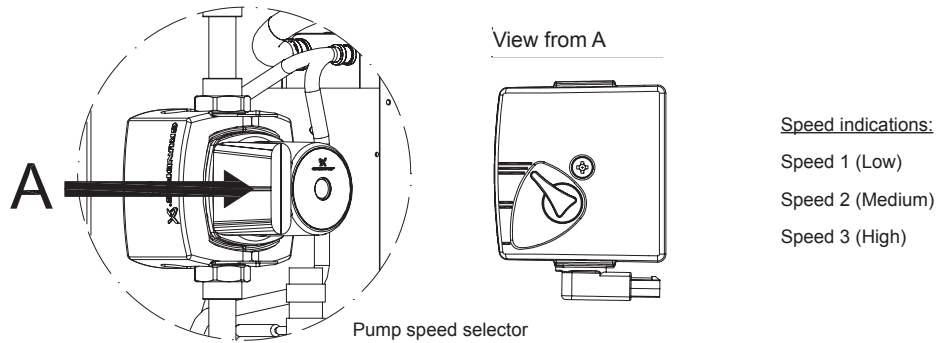

### **i** NOTE

***The Pumps are factory supplied on speed 3 (High)***

## 4 Water flow adjustment

The Water Flow should be adjusted by closing one of the main Shut-off Valves (field supplied) of the Space heating installation until the pressure matches the Pump Performance Curves.

Finally, the differential Manometer should be removed once the Water Pressure Ports are closed.

**9.2.5 Pressure charts**

◆ **RWH-(4.0-6.0)FS(V)NFE**

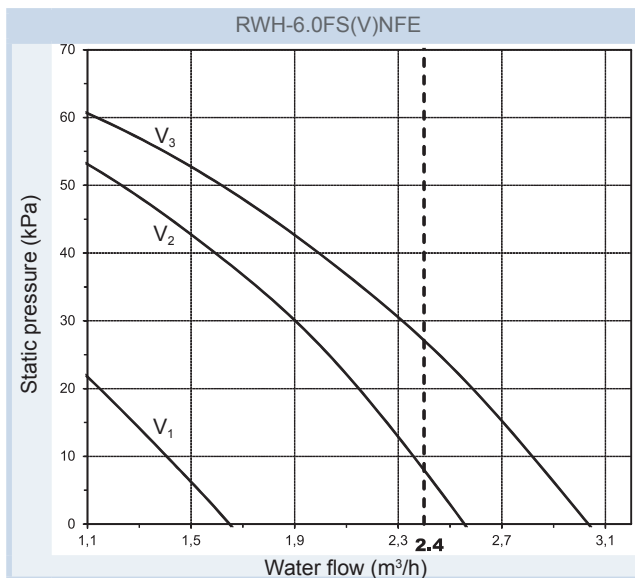
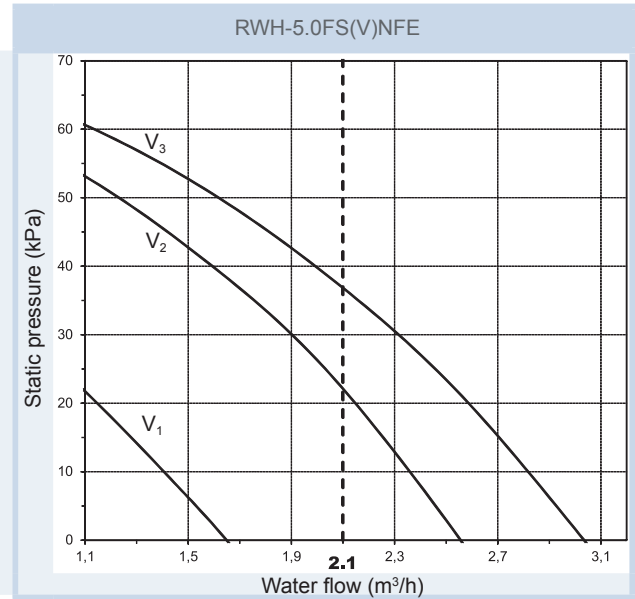
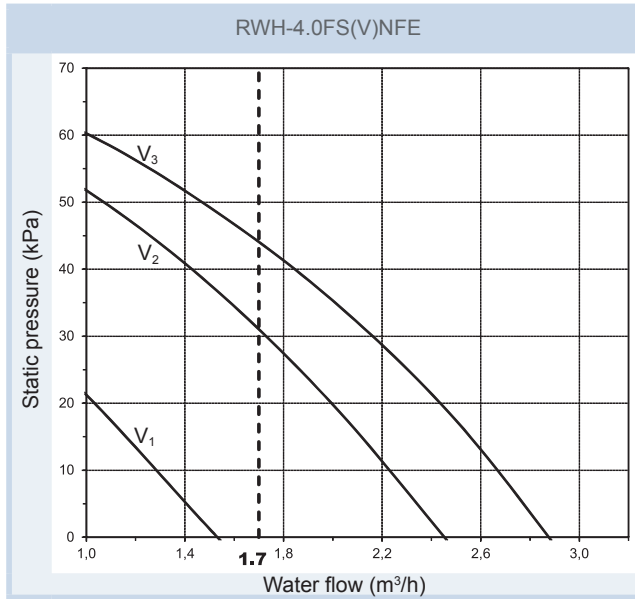

**NOTE**

V: Pump motor speed (V<sub>1</sub>: Low, V<sub>2</sub>: Medium, V<sub>3</sub>: High)

### 9.3 Domestic Hot Water hydraulic circuit (Optional)



*Do not connect the power supply to the indoor unit and DHW tank prior filling of water both circuits and checking water pressure and the total absence of any water leak.*

#### 9.3.1 Hydraulic circuit

Nature	No.	Part name
Accessories	1	Security water valve unit (DHWT-SWG-01)
	2	Water check valve (ATW-WCV-01)
Field supplied	3	Recirculation pump
	4	Shutoff valve
	5	Drain
Factory supplied	6	Heating coil
	7	Heating coil outlet water pipe (accessory)
	8	Heating coil inlet water pipe (accessory)
	9	DHW outlet water pipe (accessory)
	10	DHW inlet water pipe (accessory)

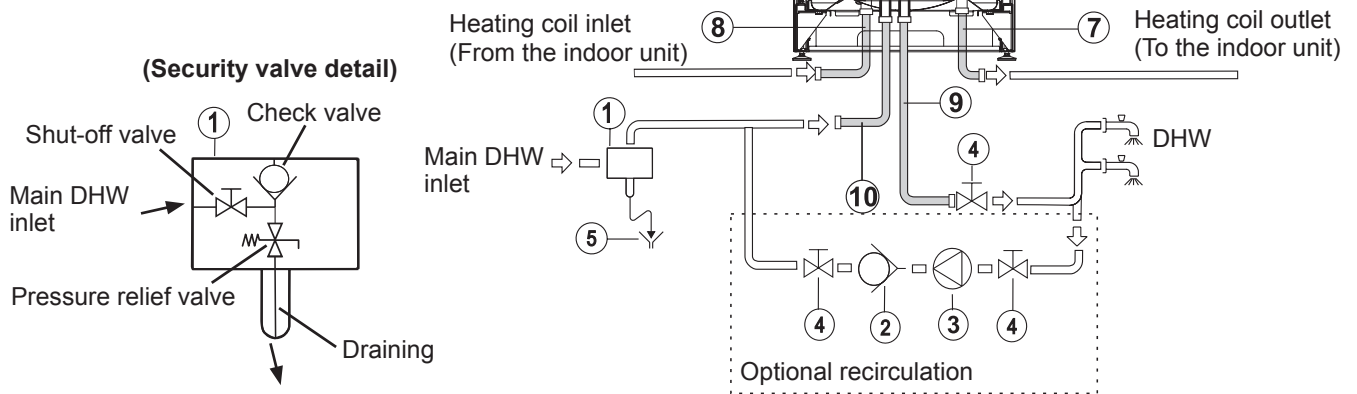
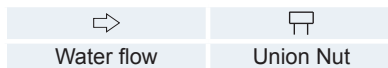

(Security valve detail)

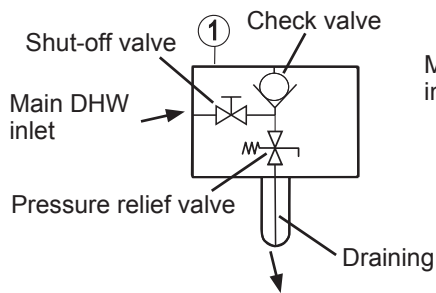

### ◆ Hydraulic necessary elements

The next hydraulic elements are necessary to correctly perform the domestic hot water circuit:

- **1 Security water valve (DHWT-SWG-01 accessory):** this Hitachi accessory (1) is a pressure and temperature relief valve that must be installed as near as possible at the DHW inlet connection before the DHW inlet water pipe factory supplied (10) (pressure setting 7 bar; temperature setting 90°C). The security water valve provides:
  - Pressure protection
  - Non-return function
  - Shut-off valve
  - Filling
  - Draining

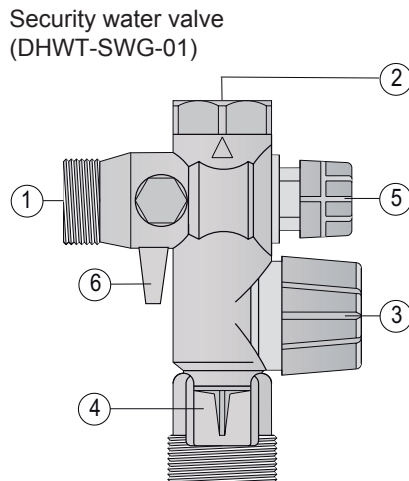

Ref.	Name
①	Main inlet water (DHW inlet)
②	DHW inlet connection
③	Pressure relief valve and manual empty
④	Emptying connection (drain pipe)
⑤	Water check valve (non return)
⑥	Shut-off valve

### **i** NOTE

*The discharge pipe should be always open to the atmosphere, free of frost and in continuous slope to the down side in case that water leakage exists.*

- **1 Shut-off valve (field supplied):** one (4) must be connected after the DHW outlet water pipe factory supplied (9) in order to make easier any maintenance work.

### ◆ Hydraulic optional elements

In case of a recirculation circuit for the DHW circuit:

- 1 Recirculation pump (field supplied): this pump (3) will help to correctly recirculate the hot water to the DHW inlet.
- 1 Water check valve (ATW-WCV-01 accessory): this Hitachi accessory (2) is connected after the pump (3) in order to ensure the non-return of water.
- 2 Shut-off valves (field supplied): one (4) before the pump (3) and one (4) after the check valve (2) in Shut-off valve (field supplied).

### **i** NOTE

*If the domestic cold water entry pressure is higher than the equipment's design pressure (6 bar), a pressure reducer must be fitted with a nominal value of 7 bar.*

### 9.3.2 Water piping

#### ◆ Water pipes connection

##### Indoor unit connections

The domestic hot water connections of indoor unit are located where it is visible in the following images:

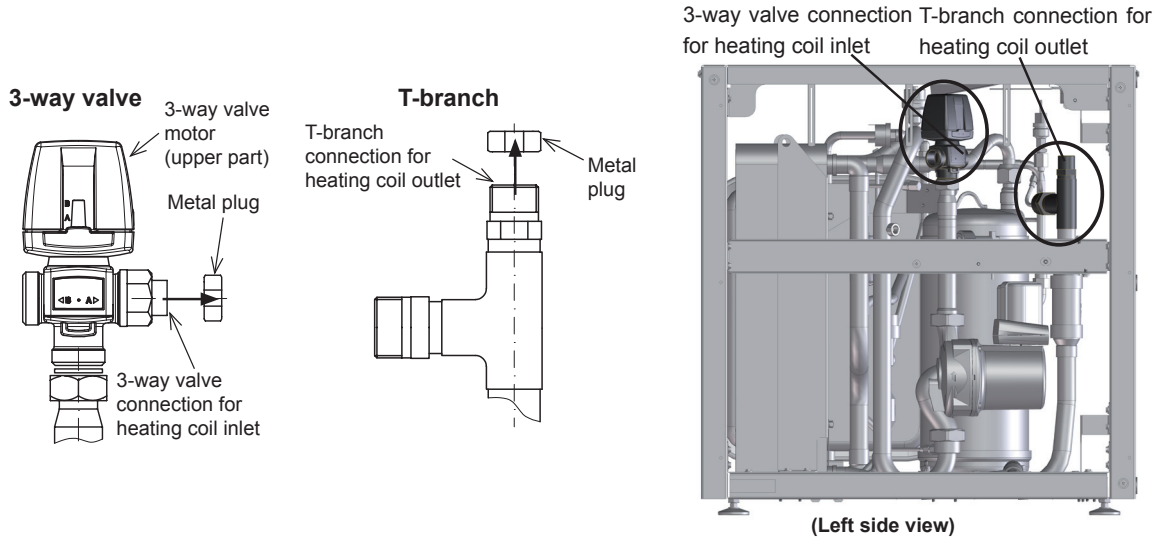

##### Tank connections

The domestic hot water connections of the tank are located where it is visible in the following images:

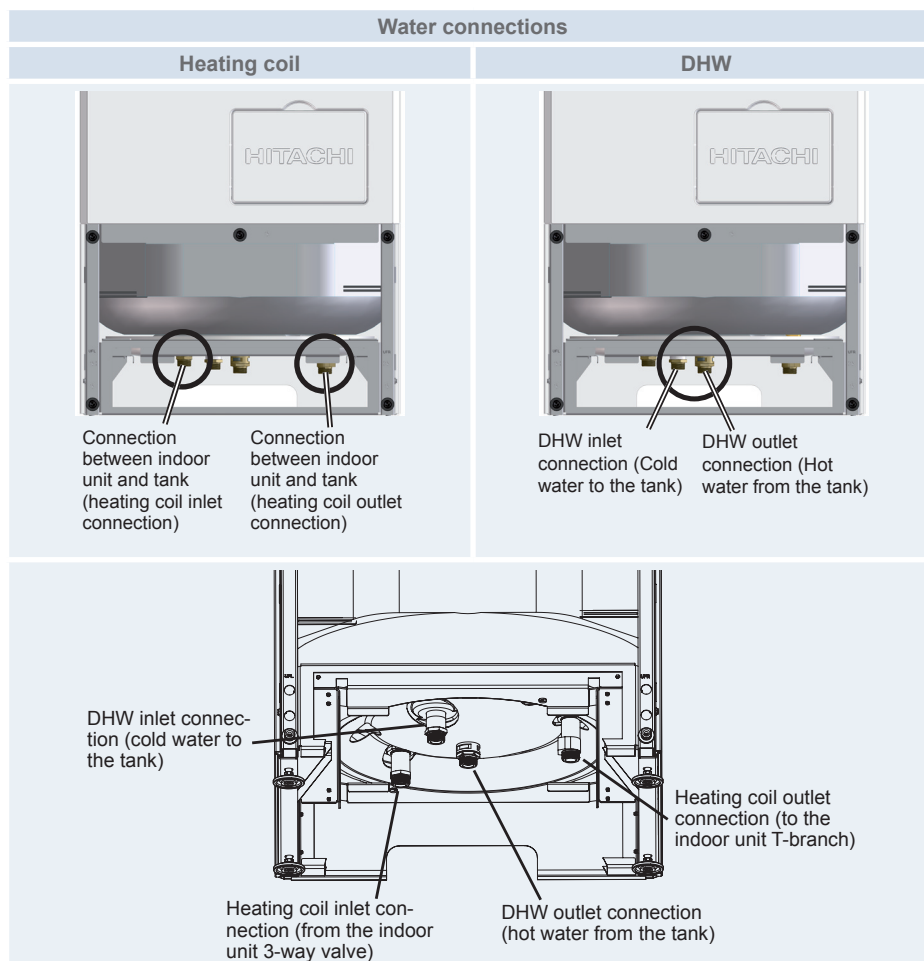

**Piping size**

(mm (inches))

	Heating coil		DHW	
	From indoor unit	To indoor unit	From DHW installation	To DHW installation
DHWS-(195/260)S-2.0H1E	Ø19.05 (3/4")	Ø19.05 (3/4")	Ø19.05 (3/4")	Ø19.05 (3/4")

◆ **Heating coil and DHW pipes (factory supplied)**

The DHW tank is factory supplied with two water pipes (heating coil pipes) to connect with the indoor unit (to the T-branch and to the 3-way valve) and other two (DHW pipes) for connection with the DHW installation.

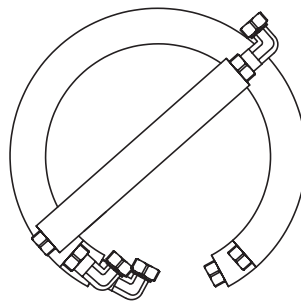

Factory-supplied with the indoor unit

Heating coil pipes	
Item	Connection
<p>Ø19.05 (3/4")</p> <p>365mm</p>	Heating coil inlet pipe For the connection between the 3-way valve water outlet and the heating coil inlet.
<p>960mm</p>	Heating coil outlet pipe For the connection between the T-branch water inlet and the heating coil outlet.

DHW pipes	
Item	Connection
<p>1045mm</p> <p>Ø19.05 (3/4")</p>	DHW inlet pipe For the connection between the DHW inlet connection (cold water to the tank) and the DHW installation.
<p>960mm</p> <p>Ø19.05 (3/4")</p>	DHW outlet pipe For the connection between the DHW outlet connection (hot water from the tank) and the DHW installation.

**i NOTE**

Please, refer to the *Installation and operation manual of the Domestic hot water tank of YUTAKI S80* for the detailed information

### 9.3.3 Water quality

#### CAUTION

- **Water quality must be according to EU council directive 98/83 EC.**
- **Water should be subjected to filtration or to a softening treatment with chemicals before application as treated water.**
- **It is also necessary to analyse the quality of water by checking pH, electrical conductivity, ammonia ion content, sulphur content, and others. Should the results of the analysis be not good, the use of industrial water would be recommended for the heating coil circuit.**
- **It is mandatory to do not add any kind of antifreeze product to the water circuit.**
- **To avoid deposits of scale on the heating coil surface it is mandatory to ensure a high water quality with low levels of CaCO<sub>3</sub>.**

The following is the recommended standard water quality.

Item	DHW space	Tendency <sup>(1)</sup>	
	Water supplied <sup>(3)</sup>	Corrosion	Deposits of scales
Electrical Conductivity (mS/m) (25°C) {μS/cm} (25 °C) <sup>(2)</sup>	100~2000	●	●
Chlorine Ion (mg Cl <sup>-</sup> /l)	max. 250	●	
Sulphate (mg/l)	max. 250	●	
Combination of chloride and sulphate (mg/l)	max. 300	●	●
Total Hardness (mg CaCO <sub>3</sub> /l)	60~150		●



#### NOTE

- (1): The mark “●” in the table means the factor concerned with the tendency of corrosion or deposits of scales.
- (2): The value showed in “{ }” are for reference only according to the former unit.
- (3): **Water range will be according s/UNE 112076:2004 IN.**



# 10. Electrical wiring

## Index

10.1. Unit electrical wiring and connection .....	114
10.1.1. General check .....	114
10.2. Electrical wiring connection .....	116
10.2.1. Outdoor unit terminal board connections .....	116
10.2.2. Indoor unit terminal board connections .....	117
10.3. Printed circuit board (PCB).....	118
10.3.1. Outdoor unit.....	118
10.3.2. Indoor unit.....	119
10.4. Setting of DIP switches and RSW switches .....	121
10.4.1. Outdoor unit.....	121
10.4.2. Indoor unit.....	124
10.5. Common wiring .....	130
10.5.1. Electrical wiring between indoor and outdoor unit of the air to water heat pump system.....	130
10.5.2. Electrical wiring between DHW tank and indoor unit.....	133

## 10.1 Unit electrical wiring and connection

### 10.1.1 General check

- 1 Ensure that the field-supplied electrical components (mains power switches, circuit breakers, wires, connectors and wire terminals) have been properly selected according to the electrical data indicated. Make sure that they comply with national and regional electrical codes.
- 2 Following the Council Directive 2004/108/EC(89/336/EEC), relating to electromagnetic compatibility, next table indicates: Maximum permissible system impedance  $Z_{max}$  at the interface point of the user's supply, in accordance with EN61000-3-11.

Outdoor unit	$Z_{max}$ ( $\Omega$ ) (*)
RAS-4HVRNME-AF	0.41
RAS-5HVRNME-AF	0.32
RAS-6HVRNME-AF	0.32
RAS-4HRNME-AF	-
RAS-5HRNME-AF	-
RAS-6HRNME-AF	-

Model	$Z_{max}$ ( $\Omega$ )	
	Indoor unit alone (Without tank)	Indoor unit with HITACHI tank
RAS-4HVRNME-AF	0.31	0.19
RAS-5HVRNME-AF	0.27	0.19
RAS-6HVRNME-AF	0.24	0.19
RAS-4HRNME-AF	-	0.37
RAS-5HRNME-AF	-	0.37
RAS-6HRNME-AF	-	0.37

#### NOTE

(\*) *In case of outdoor unit three phases connection,  $Z_{max}$  is not considered.*

- 3 Harmonics situation of each model regarding IEC 61000-3-2 and IEC 61000-3-12 is as follows:

Models situation regarding IEC 61000-3-2 and IEC 61000-3-12 Ssc "xx"	Models	Ssc "xx" (KVA)
Equipment complying with IEC 61000-3-2 (professional use)	RAS-4HRNME-AF RAS-5HRNME-AF RAS-6HRNME-AF RWH-4.0FSVNFE RWH-5.0FSVNFE RWH-6.0FSVNFE	-
Equipment complying with IEC 61000-3-12	RAS-4HVRNME-AF RAS-5HVRNME-AF RAS-6HVRNME-AF RWH-4.0FSNFE RWH-5.0FSNFE RWH-6.0FSNFE	-

- 4 Check to ensure that the power supply voltage is within +/-10% of the rated voltage.
- 5 Check to ensure that power supply has an impedance low enough to warranty not reduce the starting voltage more than 85% of the rated voltage.
- 6 Check to ensure that the capacity of power supply is enough. If not, the compressor will be not able to operate because of abnormal voltage drop at starting.
- 7 Check to ensure that the ground wire is connected.
- 8 Connect a fuse of specified capacity.

#### DANGER

- **Do not connect the power supply to the indoor unit and DHW tank prior filling of water both circuits and checking water pressure and the total absence of any water leak.**
- **Do not connect or adjust any wiring or connections unless the main power switch is OFF.**
- **Check that the earth wire is securely connected, tagged and locked in accordance with national and local codes.**
- **Be sure to use a dedicated power circuit for the indoor unit. Never use a power circuit shared by another appliance (Outdoor unit).**

**CAUTION**

- *Check to ensure that screws for terminal block are tightly tightened.*
- *Check to ensure that the indoor fan (inverter box) and the outdoor fan have stopped before electrical wiring work or periodical check is performed.*
- *Protect the indoor unit against the entry of small animals (like rats) which could making contact with the wires, the drain pipe, electrical parts and may damage unprotected parts, and at the worst, a fire will occur.*
- *Avoid the wiring from touching the refrigerant pipes, water pipes, plate edges and electrical parts inside the unit. If not do, the wires will be damaged and at worst, a fire will occur.*
- *In the indoor unit, lead the cables to the knockout hole (power, control and LCD cables) through the clamps placed in the upper part of the indoor unit, trying to keep the maximum possible distance between the control and LCD cables with the power cables.*
- *In the outdoor unit, lead the wires through the knockout hole in the side cover when using conduit.*
- *Electrical wiring must comply with national and local codes. Contact your local authority in regards to standards, rules, regulations, etc.*

**NOTE**

*Check and test to ensure that if there is more than one source of power supply, that all are turned OFF.*

## 10.2 Electrical wiring connection

### 10.2.1 Outdoor unit terminal board connections

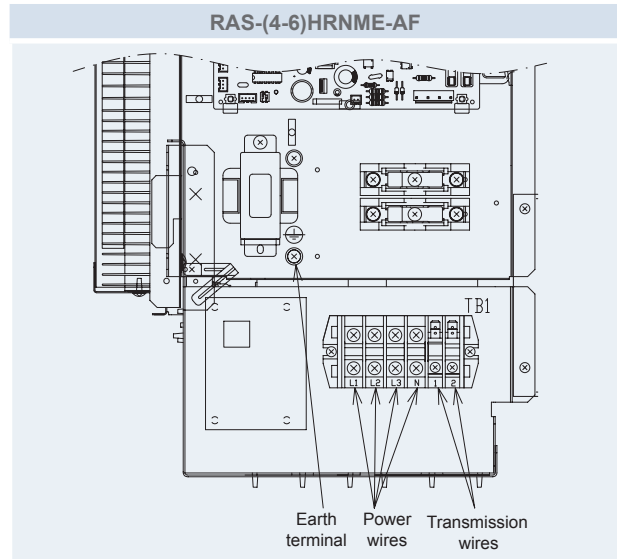
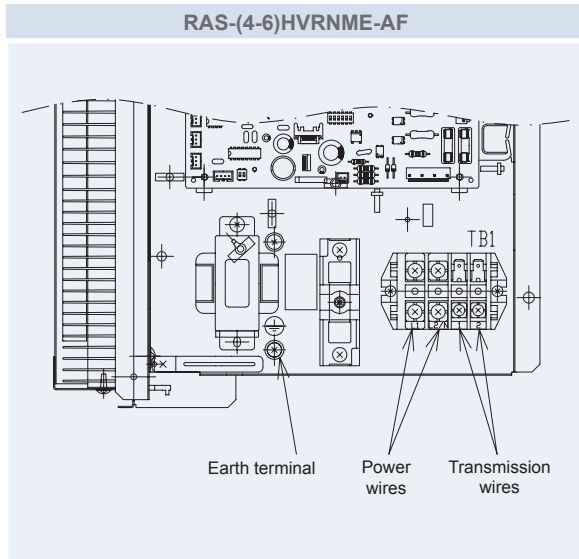

1~ 230V 50Hz

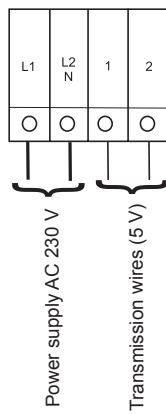

3N~ 400V 50Hz

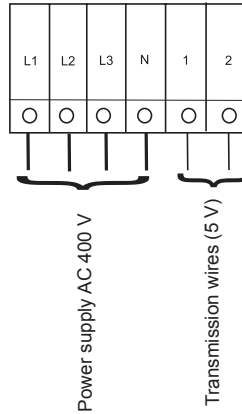

**10.2.2 Indoor unit terminal board connections**

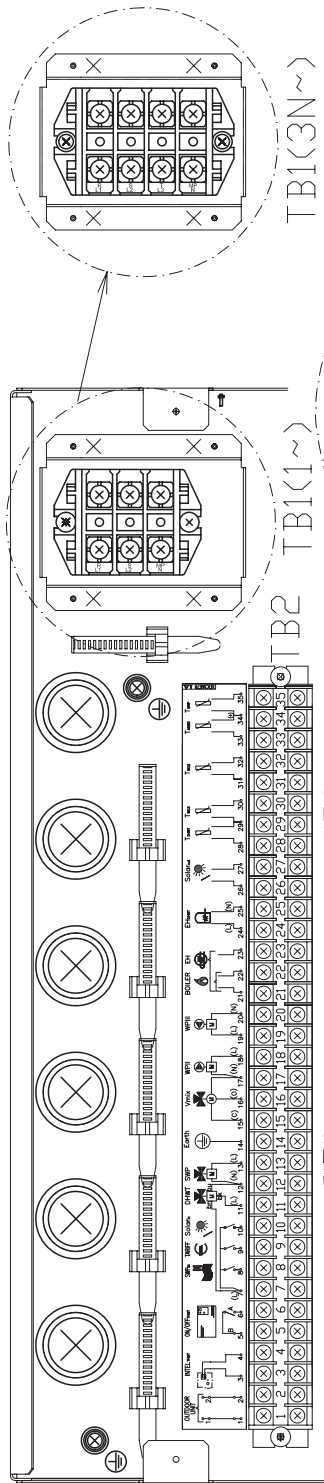

Mark	Part name	Description
<b>TERMINAL BOARD 1 (TB1)</b>		
N	1~ 230V 50Hz 3N~ 400V 50Hz	
L1		
L2		
L3		
<b>TERMINAL BOARD 2 (TB2)</b>		
1	Indoor/Outdoor commutation cables	The H-LINK transmission between outdoor unit and indoor unit is wired to terminals 1-2.
2	Opentherm communication cables	Only for Intelligent Room thermostat accessory: The receiver is connected to the polarity-free terminals A/B.
3	Optional ON/OFF Room thermostat	The air to water heat pump system is designed to allow the connection of a remote thermostat to effectively control your home's temperature. Depending on the room temperature, the thermostat will turn the air to water heat pump system ON and OFF.
4	L Common	Terminal Line common for swimming pool, tariff switch, solar input and DHW Valve accessory.
5	Swimming pool input	Only for swimming pool installations: It is necessary to connect an external input to the heat pump to provide signal when water pump of swimming pool is ON.
6	Tariff switch input	If a tariff-switching device is provided by the electricity utility, it can be used to prevent the heat pump switching ON.
7	Solar input	Available input for Solar combination with Domestic Hot Water Tank.
8	Domestic Hot Water valve	The air to water heat pump can be used to heat DHW. This output will be ON when DHW is activated.
9	N common	Neutral terminal common for accessory devices.
10	Swimming pool valve	The air to water heat pump can be used to heat Swimming pool. This output will be ON when Swimming pool is activated.
11	Earth Connection	Terminal earth connection for accessories.
12	Mixing valve close	When a mixing system is required for a second temperature control, these two outputs are necessary to control the mixing valve.
13	Mixing valve open	
14	N Common	
15	Water Pump 2 (WP2)	When there is a second temperature application, a secondary pump is the circulating pump for the secondary heating loop.
16	Water Pump 3 (WP3)	When there is a hydraulic separator or buffer tank, additional Water pump (WP3) is needed.
17	Common boiler/water electric heater	Terminal line common for combination with boiler or water electric heater.
18	Boiler/Water electric heater step 1 output	The boiler can be used to alternate with the heat pump when the heat pump cannot achieve the required temperature by itself.
19	Water electric heater step 2 output	A water electric heater (as accessory) can be used to provide the additional heating required on the coldest days of the year.
20	Electrical Heater DHW output	If DHW Storage tank contains an electric heater, the air to water heat pump can enable it if the heat pump cannot achieve the required DHW temperature itself.
21	Solar output	Output for solar combination with Domestic Hot Water Tank.
22	DHW thermistor	The DHW sensor is used to control the domestic hot water storage tank.
23	Common thermistor	Common terminal for thermistor.
24	Water outlet boiler thermistor (THMwo3)	Water sensor for boiler combination.
25	Water outlet C2 thermistor (THMwo2)	The sensor is used for the second temperature control and should be positioned after the mixing valve and the circulation pump.
26	Second ambient thermistor	The sensor is used for the second ambient temperature control and should be positioned outside.
27	Common thermistor	Common terminal for second ambient and swimming pool thermistor (+12Vcc).
28	Swimming pool thermistor	The sensor is used for the swimming pool temperature control and should be positioned inside plate HEX of swimming pool.

## 10.3 Printed circuit board (PCB)

### 10.3.1 Outdoor unit

#### ◆ RAS-(4-6)H(V)RNME-AF

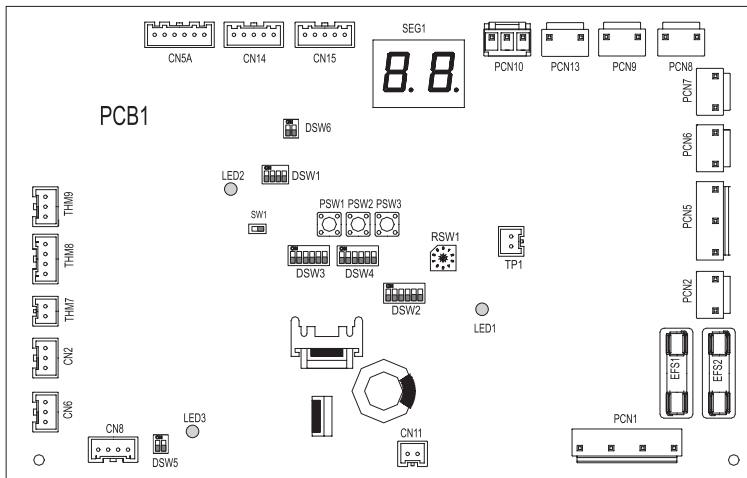

Connector indication	
PCN1	Fuse
PCN2	PCB1 connection from outdoor to indoor unit
PCN5	Crankcase heater of compressor (oil)
PCN6	Output optional function
PCN7	Output optional function
PCN8	Pressure switch protection
PCN9	Compressor contactor
PCN13	Pressure switch control
THM7	Outdoor air temperature thermistor
THM8	Pipe evaporation temperature thermistor
THM9	Compressor discharge temperature thermistor
CN2	Current transformer
CN5A	Micro electronic expansion valve
CN8	Transmission from outdoor to indoor unit
CN14	Transmission between PCB1 and ISPM
EFS1, 2	Power protection

Switch indication		
DSW1 (PCB1)		Test run
DSW2		Piping length and selection function
DSW3		Capacity code
DSW4/RSW1		Refrigerant cycle number
DSW5		End terminal resistor
DSW6		Power source setting

LED indication		
LED1	Red	This LED indicates the transmission status between the indoor unit and the RCS
LED2	Yellow	This LED indicates the transmission status between the indoor unit and the outdoor unit
LED3	Green	Power source for the PCB

### 10.3.2 Indoor unit

#### PCB1

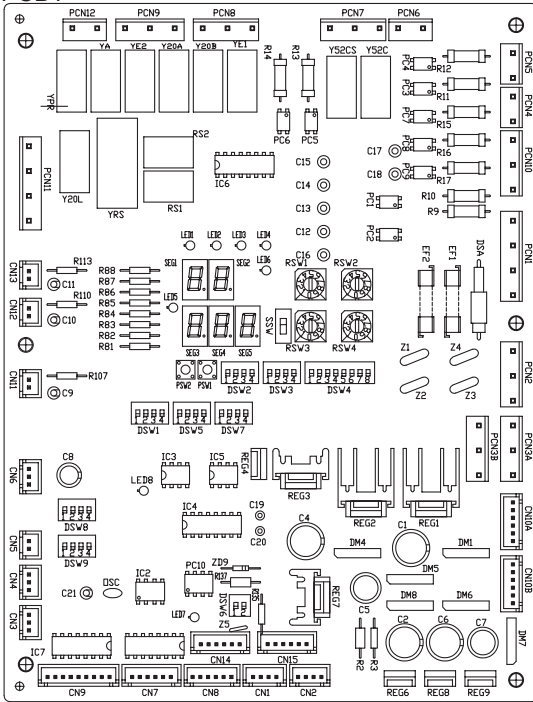

PCB1	Switch indication	
	Name	Connector No.
Operation / Display	Additional setting	DSW1
	Capacity Setting	DSW2
	Optional functions	DSW3
	Optional functions	DSW4
	Additional setting	DSW5
	H-link (transmission)	DSW6
	Not used	DSW7
	Not used	DSW8
	Not used	DSW9
	Refrigerant unit address	RSW1
	Refrigerant unit address	RSW2
	Indoor unit address	RSW3
	Indoor unit address	RSW4
	Checking Mode (Forward)	PSW1
Checking Mode (Back)	PSW2	

PCB1	LED indication	
	Name	Connector No.
LEDS	7-segment	SEG1,2,3,4,5
	Water Pump operation	LED1
	Heater or Boiler operation	LED2
	DHW Heater operation	LED3
	Heat pump operation (compressor 1)	LED4
	Power supply in the unit	LED5
	Alarm (Flickering with 1 sec interval)	LED6
	Not used	LED7
H-Link transmission	LED8	

#### PCB2

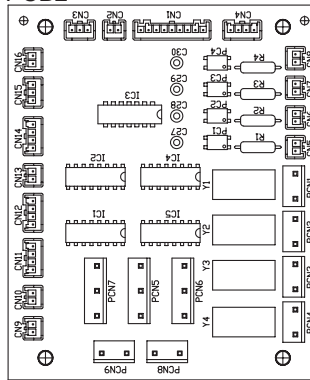

PCB1	Connector Indications	
	Name	Connector N°
Power	Power supply	PCN1
	Devices power supply	PCN2
	Input transformer power supply (230v)	PCN3A,B
	Output transformer power supply (24v)	CN10A,B
	LCD Power supply	CN15
Protection Device	Low Water Pressure & Water Flow control	PCN10-1
Transmission	H-Link communication	CN1
	PCB1-PCB2 communication	CN2,5,6,9
External Input / Output	THMswp (Swimming pool temperature)	CN3
	THMamb2 (2nd ambient temperature)	CN4
	Indoor expansion valve (EVI)	CN7a
	THMswp/amb2 power supply	CN14
	Room thermostat (ON/OFF)	PCN6-1
	Water pump 1	PCN7-5
	3-way valve swimming pool output	PCN8-1
	3-way valve DHW output	PCN8-3
	Mixing valve second temperature left	PCN9-5
	Secondary pump output (WP2)	PCN9-3
	Secondary pump output (WP3)	PCN9-1
	Swimming pool input	PCN10-5
Electrical Tariff input	PCN10-3	
Solar input	PCN7-1	
Mixing valve second temperature right	PCN12-3	

PCB2	Connector Indications	
	Name	Connector N°
Actuator	Boiler signal / Heater signal	PCN1
	Boiler signal / Heater signal	PCN2
	DHWT heater signal	PCN3
	Solar signal	PCN4
Transmission	PCB1-PCB2 communication	CN1,2,3,4
A/D Input	Water inlet Thermistor (THMwi)	CN9
	Water sanitary tank thermistor (THM <sub>DHW</sub> )	CN10
	Liquid 410A Thermistor (THMI)	CN11
	Gas 410A Thermistor (THMg)	CN12
	Water outlet Thermistor (THMwo)	CN13
	Boiler / heater Thermistor (THMwo3)	CN14
	Circuit 2 Thermistor (THMwo2)	CN16

PCB3

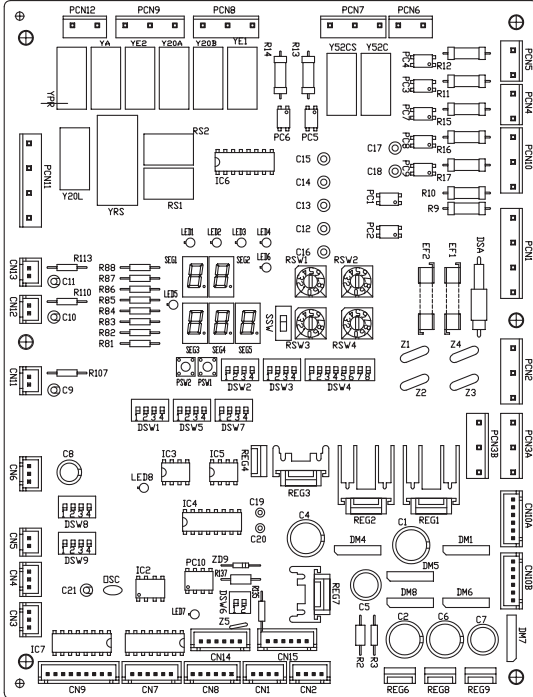

PCB4

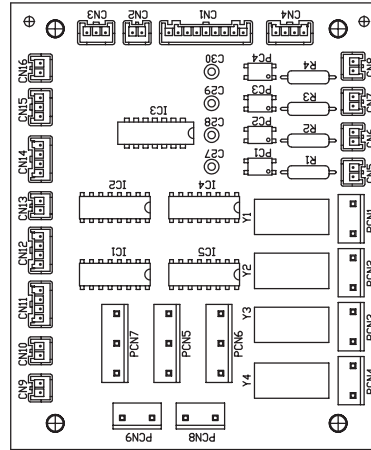

PCB3	Switch indication	
	Name	Connector No.
Operation / Display	Not used	DSW1
	Capacity Setting	DSW2
	Not used	DSW3
	Additional setting	DSW4
	Power source setting	DSW5
	H-link (transmission)	DSW6
	Unit control configuration	DSW7
	Pressure device setting 1	DSW8
	Pressure device setting 2	DSW9
	Not used	
		RSW2
		RSW3
		RSW4
Checking Mode (Forward)	PSW1	
Checking Mode (Back)	PSW2	

PCB3	LED indication	
	Name	Connector No.
LEDS	7-segment	SEG1,2,3,4,5
	Power supply indication	LED1
	Not used	LED2
	Not used	LED3
	Heat pump operation (compressor 2)	LED4
	Alarm (flickering with 1 sec interval)	LED5
	Not used	LED6
	Not used	LED7
H-Link transmission	LED8	

PCB3	Connector Indications	
	Name	Connector N°
Power	Power supply	PCN1
	Devices power supply	PCN2
	Input transformer power supply (230v)	PCN3A,B
	Output transformer power supply (24v)	CN10A,B
Pro-tection Device	High pressure protection (t-out)	PCN5
Trans- mission	H-Link communication	CN1
	PCB1-PCB2 communication	CN2,5,6,9
External Input / Output	Inverter communication	CN8
	Pressure sensor (discharge) (R134a)	CN3
	Pressure sensor (suction) (R134a)	CN4
	R134a expansion valve (MV2)	CN7a
	Inverter communication	CN8
	CMC Compressor (52C)	PCN7-3
Solenoid valve 1 (SV1)	PCN9-5	
Solenoid valve 2 (SV2)	PCN9-3	
Cranksheater (CHn)	PCN12-3	

PCB4	Connector Indications	
	Name	Connector N°
Trans- mission	PCB3-PCB4 communication	CN1,2,3,4
A/D Input	R134a Suction Thermistor (THMs)	CN11
	R134a Evaporation heating Thermistor (THMeh)	CN12
	Inverrrer EBOX ambient temperature Ther- mistor (THinv)	CN10
	R134a Evaporation cooling Thermistor (THMec)	CN14
R134a Discharge Thermistor (THMd)	CN15	



## 10.4 Setting of DIP switches and RSW switches

### 10.4.1 Outdoor unit

#### ◆ Location of DIP switches and RSW switches

The PCB in the outdoor unit is operated with different dip switches, rotary switches and push switches.

Position switches at the PCB:

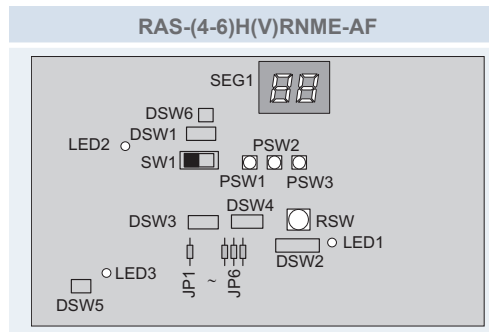

#### ◆ Function of the of DIP switches and RSW switches



#### NOTE

- The mark “■” indicates the position of dips switches.
- No mark “■” indicates pin position is not affecting.
- The figures show the settings before shipment or after selection.



#### CAUTION

Before setting dips switches, first turn the power source off and then set the position of the dips switches. In case of setting the switches without turning the power source off, the contents of the setting are invalid.

#### DSW1: Test run





Function	Setting position
Setting before shipment	
Test run for pumping down	
Test run for heating	
Forced stop of compressor <i>The compressor is OFF during this operation.</i>	

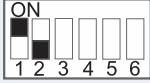

#### NOTE

- This operation is reset once the compressor is in Thermo-ON mode.
- During the test run operation the units will operate continuously during 2 hours without Thermo-OFF and the 3-minute guard for compressor protection will be effective.

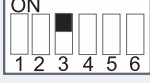
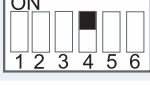

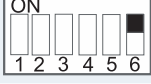

**DSW2: Piping length/selection function**

Function		Setting position
Setting before shipment		
Piping length	5 m < Lt	
	5 m < Lt < 30 m	
Cancellation of outdoor hot start control. (Not recommended, only available for special testing cases)		
Cancellation of outdoor air temperature control. (No change)		
Optional function selection setting (set by PSW)		
External input/output selection signals (set by PSW)		

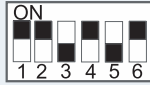

**CAUTION**

*It is possible to select the cancellation of the outdoor hot start control by pushing both PSW1 & PSW3 simultaneously during 3 seconds. The cancellation of the outdoor hot start control configuration could damage the compressor if it is usually used. In that case the unit warranty will be voided.*

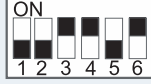
**DSW3: Capacity setting**

Unit	Setting position	Unit	Setting position
RAS-4HVRNME -AF		RAS-4HRNME-AF	
RAS-5HVRNME -AF		RAS-5HRNME -AF	
RAS-6HVRNME-AF		RAS-6HRNME -AF	

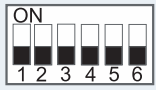
**DSW4/RSW1: Refrigerant cycle setting (No change)**

Setting position (DSW4)		Setting position (RSW1)	
Setting for tens (second digit)		Setting for units (first digit)	



Rotary switches' positions (RSW1) are set by inserting a screw driver into the groove.

**DSW5: Transmission setting of end terminal resistance**

Before shipment, No. 1 pin of DSW5 is set at ON.

Function	Setting position
Setting before shipment	

**DSW6: Power source setting/individual operation**

Function	Setting position (4/5/6)HP
230V (setting before shipment)	
400V (setting before shipment)	

**◆ Jumpers**
**Jumper lead setting (JP1~6)**

Setting before shipment:

JP1	JP2	JP3	JP4	JP5	JP6
1	0	0	1	1	1

0 = Open; 1 = Short circuit

**◆ LED's indication**

LED Indication		
LED1	Red	This LED indicates the transmission status between the indoor unit and the RCS
LED2	Yellow	This LED indicates the transmission status between the indoor unit and the outdoor unit
LED3	Green	Power source for the PCB

### 10.4.2 Indoor unit

#### ◆ Location of DIP switches and RSW switches

Below are the dip switch positions:

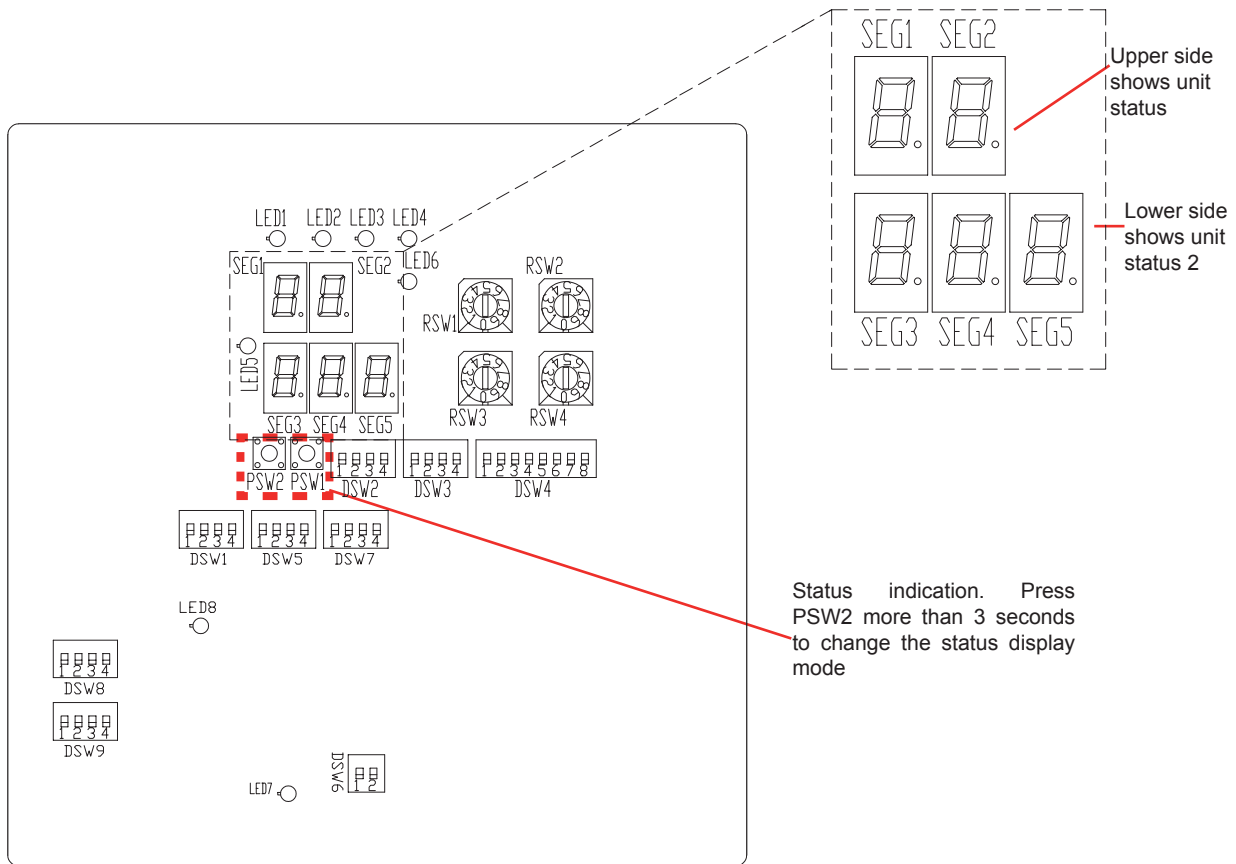

#### ◆ Functions of dip switches and rotary switches



#### NOTE

- The mark “■” indicates the dip switches positions.
- No mark “■” indicates pin position is not affected.
- The figures show the settings before shipment or after selection.
- “Not used” means that the pin must not be changed. A malfunction might occur if changed.



#### CAUTION

Before setting dip switches, first turn the power supply OFF and then set the position of dip switches. If the switches are set without turning the power supply OFF, the contents of the setting are invalid.

#### PCB1

##### ◆ DSW1: Additional setting 1

Factory setting	
Open SV1/2 for vacuum and refrigerant R410A recover function	

◆ **DSW2: Capacity setting**

No setting is required.

RWH-4.0FS(V)NFE	
RWH-5.0FS(V)NFE	
RWH-6.0FS(V)NFE	

◆ **DSW3: Optional functions 1**

Factory setting	
1 step heater for 3 phase unit	

◆ **DSW4: Optional functions 2**

Factory setting	
Optional functions enabled	
Heater Forced OFF	
Unit and installation pipes antifreeze protection	
Standard / ECO water pump operation	
Emergency operation heater / boiler	
Outdoor unit refrigerant R410A recovery	
Outdoor sensor accessory	
DHW tank's heater enabled operation	

 **CAUTION**

- **Never turn all DSW4 dip switch pins ON. If this happens, the software of the unit will be removed.**
- **Never activate Heater Forced OFF and Emergency operation heater at the same time.**

**◆ DSW5: Additional setting 2**

In the cases where the outdoor unit is installed into a location where its own outdoor ambient temperature sensor can not give a suitable temperature measurement to the system, it is available the 2nd outdoor ambient temperature sensor as accessory.

By means of DSW setting, it can be selected the preferable sensor for each circuit.

**NOTE**

**Switch ON the DSW4-2 to enable this additional setting.**

Factory setting	
Outdoor unit sensor for circuits 1 and 2.	
Outdoor unit sensor for circuit 1; Auxiliary sensor for circuit 2.	
Auxiliary sensor for circuit 1; Outdoor unit sensor for circuit 2.	
Auxiliary sensor instead of outdoor unit sensor for both circuits.	
Universal sensor enabled	
Use Two3 (boiler / heater thermistor) instead Two (water outlet thermistor) for water control	

**◆ DSW6: Not used**

Factory setting (Not change)	
---------------------------------	--

**◆ DSW7: Not used**

Factory setting (Not change)	
---------------------------------	--

**◆ DSW8: Not used**
**◆ DSW9: Not used**
**◆ RSW1 & RSW2: Refrigerant system setting**

RSW1: Ten digits RSW2: Unit digits	
---------------------------------------	--

**◆ RSW3 & RSW4: Indoor unit address setting**

RSW3: Ten digits RSW4: Unit digits	
---------------------------------------	--

**PCB3**

◆ **DSW1: Not used**

Factory setting (Not change)	
---------------------------------	---

◆ **DSW2: Capacity setting**

No setting is required.

RWH-4.0FS(V)NFE	
-----------------	---

RWH-5.0FS(V)NFE	
-----------------	---

RWH-6.0FS(V)NFE	
-----------------	---



◆ **DSW3: Not used**

Factory setting (Not change)	
---------------------------------	---

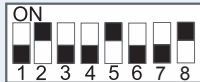
◆ **DSW4: Additional setting**

Factory setting (Not change)	<b>Single phase</b> (1~ 230V 50Hz)	<b>Three phase</b> (3N~ 400V 50Hz)
		



◆ **DSW5: Power source setting**

Factory setting	<b>Single phase</b> (1~ 230V 50Hz)	<b>Three phase</b> (3N~ 400V 50Hz)
		

◆ **DSW6: Not used**

Factory setting (Not change)	
---------------------------------	---

**◆ DSW7: Unit control configuration**

	Single phase (1~ 230V 50Hz)	Three phase (3N~ 400V 50Hz)
Factory setting		

**◆ DSW8: Pressure device setting 1**

Factory setting (Not change)	
---------------------------------	---

**◆ DSW9: Pressure device setting 2**

Factory setting (Not change)	
---------------------------------	---

**◆ RSW1 & RSW2: Not used**
**◆ RSW3 & RSW4: Not used**



**◆ Led indications**
**PCB1**

Name	Color	Indication
LED1	Green	Pump operation
LED2	Green	System heater or boiler operation
LED3	Green	DHW tank's heater operation
LED4	Red	Heat pump operation (thermo ON/OFF)
LED5	Yellow	Operation: indicates power supply to the unit
LED6	Red	Alarm (flickering with 1 sec interval)
LED7	-	Not used
LED8	Yellow	H-link indication transmission

**PCB3**

Name	Color	Indication
LED1	Green	Power supply indication
LED2	-	Not used
LED3	-	Not used
LED4	Red	Heat pump operation (compressor 2)
LED5	Yellow	Alarm (flickering with 1 sec interval)
LED6	-	Not used
LED7	-	Not used
LED8	Yellow	H-link indication transmission

## 10.5 Common wiring

### 10.5.1 Electrical wiring between indoor and outdoor unit of the air to water heat pump system

- Connect the electrical wires between the indoor unit and the outdoor unit, as shown in the next diagram.
- Use twist pair wires (more than 0.75 mm<sup>2</sup>) for operation wiring between outdoor unit and indoor unit.
- Use 2-core wires for the operating line (Do not use wire with more than 3 cores).
- Use shielded wires for intermediate wiring to protect the units from noise obstacle at length of less than 300m and size in compliance with local codes.
- In the event that a conduit tube for field-wiring is not used, fix rubber bushes to the panel with adhesive.



#### CAUTION

- **Be sure to use a dedicated power circuit for the indoor unit. Never use a power circuit shared by another appliance (Outdoor unit).**
- **Pay attention to the connection of the operating line. Incorrect connection may cause PCB failure.**
- **All the field wiring and equipment must comply with local and international codes.**

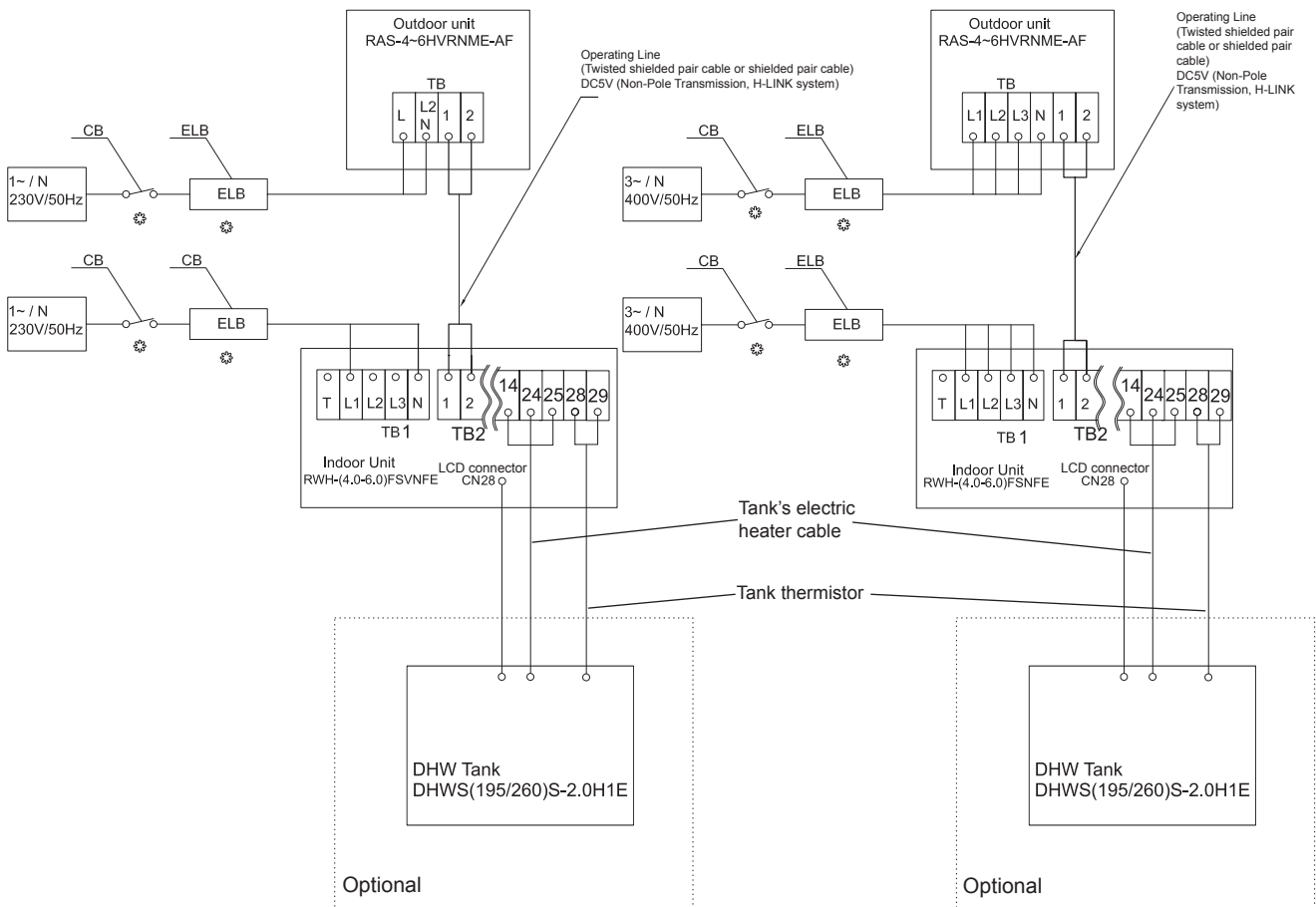

- TB : Terminal Board  
 CB : Circuit Breaker  
 ELB : Earthleakage Breaker  
 --- : Internal Wiring  
 — : Field Wiring  
 : Field-Supplied  
 1,2 : Outdoor-Indoor connection

**◆ Recommended minimum sizes for field provided wires**

**NOTE**

- Follow local codes and regulations when selecting field wires, circuit breakers and earth leakage breakers.
- Use the wires which are not lighter than the ordinary polychloroprene sheathed flexible cord (code designation H05RN-F).
- (\*1): The DHW tank heater is intended to be used in case of indoor and/or outdoor unit malfunction. If the DHW tank heater is enabled during the indoor unit operation, CB and ELB could switch off. If it is desired to enable the DHW tank heater operation during normal indoor unit operation, adjust the DSW4 pin 1 of the PCB1 to the ON position and consider the protections as indicated in "Indoor unit + DHW tank heater combination" on the table.

**Outdoor unit**

Model	Power supply	Max. Current (A)	Power supply cables	Transmitting cables	Actuator cables
			EN60335-1	EN60335-1	EN60335-1
RAS-4HVRNME-AF	1~ 230V 50Hz	18.0	2 x 4.0 mm <sup>2</sup> + GND	2 x 0.75 mm <sup>2</sup> (*Shielded cable)	2 x 0.75 mm <sup>2</sup> + GND
RAS-5HVRNME-AF		23.0	2 x 6.0 mm <sup>2</sup> + GND		
RAS-6HVRNME-AF		23.0	2 x 6.0 mm <sup>2</sup> + GND		
RAS-4HRNME-AF	3N~400V 50 Hz	7.0	4 x 2.5 mm <sup>2</sup> + GND		
RAS-5HRNME-AF		11.0	4 x 4.0 mm <sup>2</sup> + GND		
RAS-6HRNME-AF		13.0	4 x 4.0 mm <sup>2</sup> + GND		

**Indoor unit alone**

Model	Power supply	Max. current (A)	Power supply cables	Transmitting cables	Actuator cables	
			EN60335-1	EN60335-1	EN60335-1	
RWH-4.0FSVNFE	1~ 230V 50Hz	24.0	2 x 6.0mm <sup>2</sup> + GND	2 x 0.75mm <sup>2</sup> (*Shielded cable)	2 x 0.75mm <sup>2</sup> + GND	
RWH-5.0FSVNFE		28.0				
RWH-6.0FSVNFE		31.0				
RWH-4.0FSNFE	3N~ 400V 50Hz	15.0				4 x 2.5mm <sup>2</sup> + GND
RWH-5.0FSNFE		15.0				
RWH-6.0FSNFE		15.0				

**Indoor unit with DHW tank**

Model	Indoor Unit Model	Operation mode (*1)	Power supply	Max. current (A)	Power supply cables	Transmitting cables	Actuator cables
					EN60335-1	EN60335-1	EN60335-1
RWH-(4.0-6.0)FSVNFE + DHWS-(195/260)S-2.0H1E	RWH-4.0FSVNFE	Standard operation (By default)	1~ 230V 50Hz	24.0	2 x 6.0mm <sup>2</sup> + GND	2 x 0.75mm <sup>2</sup> (*Shielded cable)	2 x 0.75mm <sup>2</sup> + GND
	RWH-5.0FSVNFE			28.0			
	RWH-6.0FSVNFE			31.0			
	RWH-4.0FSNFE	Indoor unit + DHW tank heater combi- nation		33.0	2 x 10.0mm <sup>2</sup> + GND		
	RWH-5.0FSNFE			37.0			
	RWH-6.0FSNFE			40.0			
RWH-(4.0-6.0)FSNFE + DHWS-(195/260)S-2.0H1E	RWH-4.0FSVNFE	Standard operation (By default)	3N~ 400V 50Hz	15.0	4 x 2.5mm <sup>2</sup> + GND		
	RWH-5.0FSVNFE			15.0			
	RWH-6.0FSVNFE			15.0			
	RWH-4.0FSNFE	Indoor unit + DHW tank heater combi- nation		25.0	4 x 4.0mm <sup>2</sup> + GND		
	RWH-5.0FSNFE			25.0			
	RWH-6.0FSNFE			25.0			

**◆ Main switch protection**
**Outdoor unit**

Model	Power supply	Applicable voltage		Max. Current (A)	CB (A)	ELB (no. of poles/A/mA)
		U max. (V)	U min. (V)			
RAS-4HVRNME-AF	1~230V 50Hz	253	207	18.0	20	2/40/30
RAS-5HVRNME-AF				23.0	25	
RAS-6HVRNME-AF				23.0	25	
RAS-4HRNME-AF	3N~400V 50 Hz	440	360	7.0	15	4/40/30
RAS-5HRNME-AF				11.0	20	
RAS-6HRNME-AF				13.0	20	

MC: Maximum current; CB: Circuit breaker; ELB: Earth leakage breaker

**Indoor unit alone**

Model	Power supply	Applicable voltage		MC (A)	CB (A)	ELB (n° poles/A/mA)
		U max. (V)	U min. (V)			
RWH-4.0FSVNFE	1~ 230V 50Hz	253	207	24.0	32	2/40/30
RWH-5.0FSVNFE				28.0	32	
RWH-6.0FSVNFE				31.0	32	
RWH-4.0FSNFE	3N~ 400V 50Hz	440	360	15.0	15	4/40/30
RWH-5.0FSNFE				15.0	15	
RWH-6.0FSNFE				15.0	15	

MC: Maximum current; CB: Circuit breaker; ELB: Earth leakage breaker

**Indoor unit with DHW tank**

Model	Indoor Unit Model	Operation mode (*1)	Power supply	Applicable voltage		MC (A)	CB (A)	ELB (n° poles/A/mA)
				U max. (V)	U min. (V)			
RWH-(4.0-6.0)FSVNFE + DHWS-(195/260)S-2.0H1E	RWH-4.0FSVNFE	Standard operation (By default)	1~ 230V 50Hz	253	207	24.0	32	2/40/30
	RWH-5.0FSVNFE					28.0	32	
	RWH-6.0FSVNFE					31.0	32	
	RWH-4.0FSNFE	Indoor unit + DHW tank heater combination				33.0	40	2/63/30
	RWH-5.0FSNFE					37.0	40	
	RWH-6.0FSNFE					40.0	40	
RWH-(4.0-6.0)FSNFE + DHWS-(195/260)S-2.0H1E	RWH-4.0FSVNFE	Standard operation (By default)	3N~ 400V 50Hz	440	360	15.0	15	4/40/30
	RWH-5.0FSVNFE					15.0	15	
	RWH-6.0FSVNFE					15.0	15	
	RWH-4.0FSNFE	Indoor unit + DHW tank heater combination				25.0	25	4/40/30
	RWH-5.0FSNFE					25.0	25	
	RWH-6.0FSNFE					25.0	25	

MC: Maximum current; CB: Circuit breaker; ELB: Earth leakage breaker

### 10.5.2 Electrical wiring between DHW tank and indoor unit

The supplied wires for the connection between the DHW tank and the indoor unit are as follows:

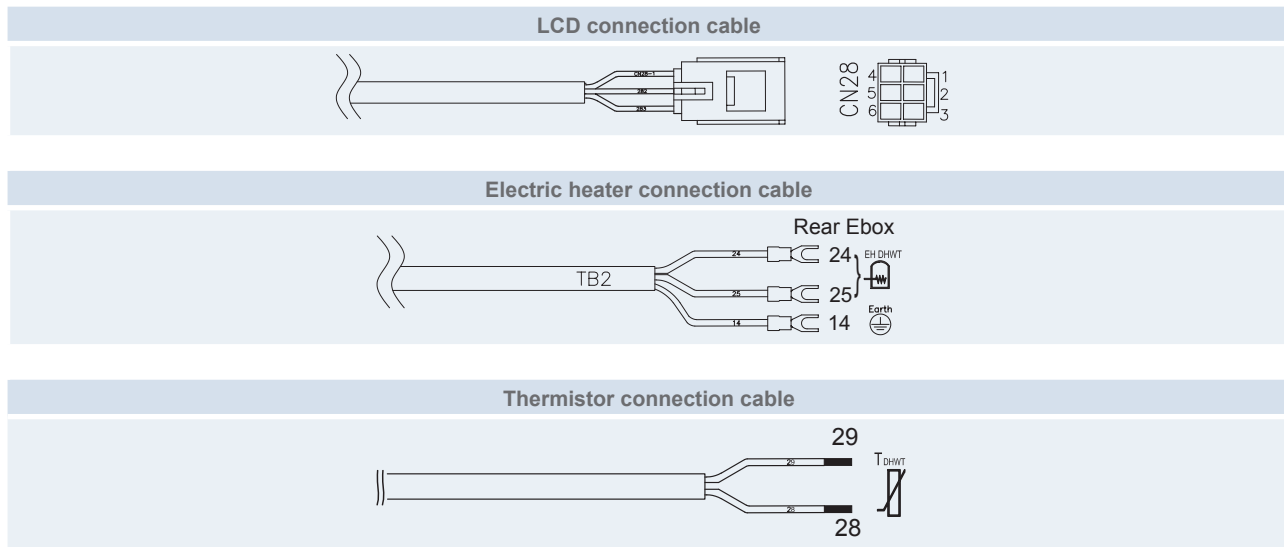

◆ **Factory supplied wire sizes**

Model	Power supply	Maximum Current (A)	LCD connection cable size	Electric heater connection cable size	Thermistor connection cable size
			EN60335-1	EN60335-1	EN60335-1
DHWS195S-2.0H1E	1~ 230V 50Hz	8.7	6 x 0.3 mm <sup>2</sup>	3 x 1.0 mm <sup>2</sup>	2 x 0.75 mm <sup>2</sup>
DHWS260S-2.0H1E					



# 11. Installation configuration

## Index

11.1. System configurations .....	136
11.2. Installation configurations .....	138
11.2.1. Main configurations .....	139
11.2.2. Additional combinations .....	142

## 11.1 System configurations

The YUTAKI S80 will generate hot water up to 80°C and it is ideal for existing properties, in particular older establishments where higher water supply temperatures may be required to keep the house warm – as well as for new builds. It is designed for boiler substitution, offering heating and sanitary hot water all year round, without boiler back-up.

The YUTAKI S80 is designed to work in a mono-valent, mono-energetic or bi-valent heating systems. It provides efficient control and reduces energy use while maintaining comfort in the building.

The functionality of the YUTAKI S80 unit depends on the installed components and the selected configuration and it can be configured and upgraded to meet many application requirements.

### ◆ Mono-valent system

The YUTAKI S80 is sized to provide 100% of the heating requirements on the coldest days of the year.

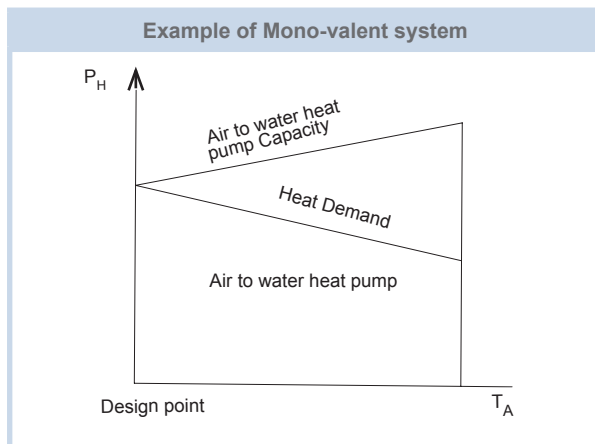

#### **i** NOTE

- $T_A$ : Outdoor ambient temperature.
- $P_H$ : Heating capacity.

### ◆ Mono-energy system

The YUTAKI S80 is sized to provide approximately 80% of the heating requirements in the coldest days of the year. An auxiliary electric heater (as accessory) is used to provide the additional heating required on cold days.

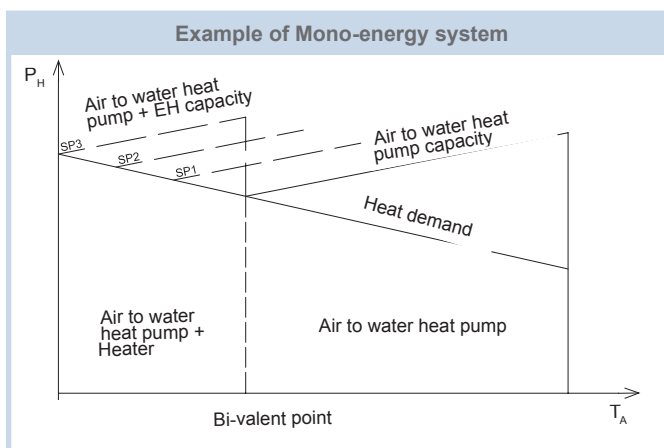

#### **i** NOTE

- $T_A$ : Outdoor ambient temperature.
- $P_H$ : Heating capacity.
- SP1/2/3: Heater steps.
- Bivalent point can be set through the LCD user's interface.



**◆ Alternating Bi-valent system**

The boiler is configured to alternate with the split air to water heat pump. A hydraulic separator or buffer tank has to be used to ensure hydraulic balancing.

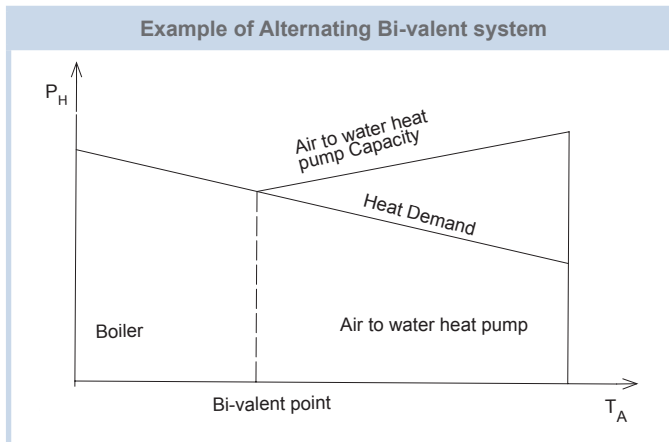
**i NOTE**

- $T_A$  : Outdoor ambient temperature (°C).
- $P_H$  : Heating capacity.
- Bivalent point can be set through the LCD user's interface.

## 11.2 Installation configurations

### **i** NOTE

- **The following installation examples show typical configurations. In case of variations of them, the responsibility of correct system functioning will be of the installer.**
- **The configuration examples given below are only for illustration purposes.**

Type	Description	Space heating		DHW Tank (accessory)	Thermostat (optional)	Heating complement		Solar Kit (field supplied)	Swimming pool
		Radiator/Fan coil	Floor			Electric heater (accessory)	Boiler		
<b>Main configurations</b>									
1	<b>One space heating only</b> Space heating installation by radiators or fan coils application, with a room thermostat as an option	○	✗	✗	○	✗	✗	✗	✗
2	<b>One space heating only and DHW tank</b> Space heating installation (by radiators or fan coils application) + DHW tank, with a room thermostat as an option.	○	✗	○	○	✗	✗	✗	✗
3	<b>Two space heating only</b> Two space heating applications (high & low water temperature), with a room thermostat as an option.	○	○	✗	○	✗	✗	✗	✗
4	<b>Two space heating only and DHW tank</b> Two space heating applications (high & low water temperature) + DHW tank, with a room thermostat as an option.	○	○	○	○	✗	✗	✗	✗
<b>Additional combinations</b>									
The next configurations are combinable with the main configurations (1 or 2 space heating, with/without tank)									
5	<b>Electric heater complement</b> Two possible space heating applications (high & low water temperature) + Electric heater (accessory) + optional DHW tank, with a room thermostat as an option.	○	○	○	○	○	✗	✗	✗
6	<b>Boiler complement</b> Two possible space heating applications (high & low water temperature) + Boiler complement + optional DHW tank, with a room thermostat as an option.	○	○	○	○	✗	○	✗	✗
7	<b>Solar complement</b> Two possible space heating applications (high & low water temperature) + Solar combination + optional DHW tank + optional Heating complement, with a room thermostat as an option.	○	○	○	○	○	✗	○	✗
8	<b>Swimming pool combination</b> Two possible space heating applications (high & low water temperature) + Swimming pool combination + optional DHW tank + optional Heating complement + optional Solar combination, with a room thermostat as an option.	○	○	○	○	○	✗	○	○

### **i** NOTE

**Only one heating complement (or boiler or electric heater) can be installed at the same installation.**

### 11.2.1 Main configurations

#### ◆ One space heating only (Installation example 1)

One space heating only: Space heating using radiators or fan coils with an optional room thermostat. The necessary LCD controller is supplied as accessory.

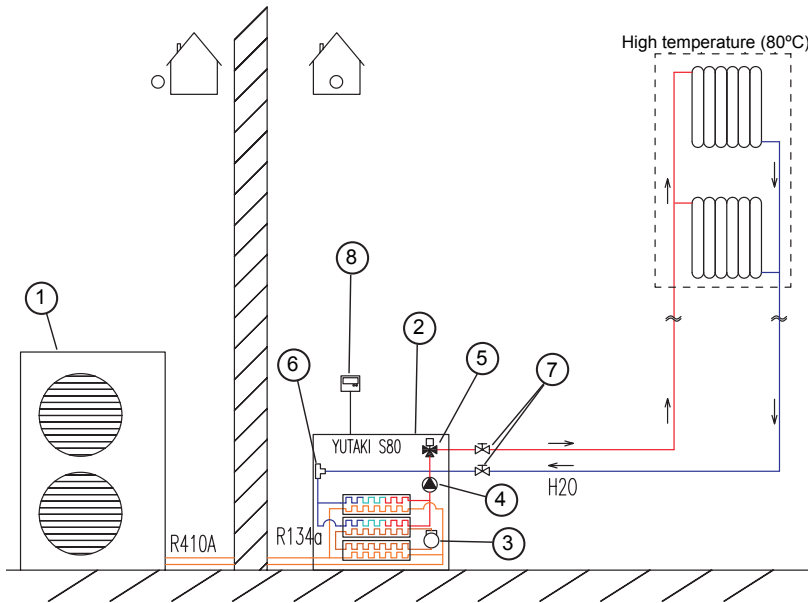

Item	Description
1	Outdoor unit
2	Indoor unit
3	R134a compressor
4	Water pump
5	3-way valve
6	T-branch
7	Shut-off valves (field supplied)
8	LCD controller (accessory)

#### ◆ One space heating and DHW Tank (Installation example 2)

One space heating and DHW Tank: Space heating using radiators or fan coils with an optional room thermostat. Domestic Hot Water Tank is heated by Heat Pump. The LCD is integrated with the DHW Tank.

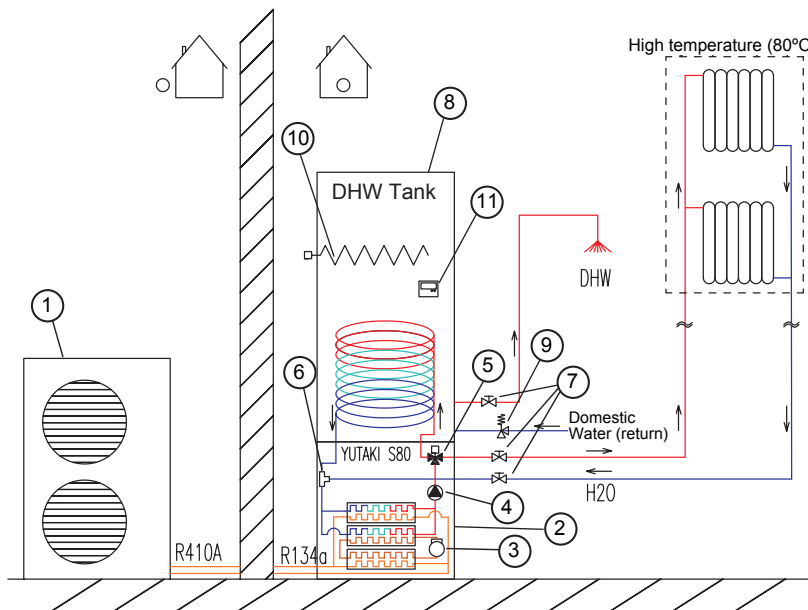

Item	Description
1	Outdoor unit
2	Indoor unit
3	R134a compressor
4	Water pump
5	3-way valve
6	T-branch
7	Shut-off valves (field supplied)
8	Domestic hot water tank
9	Security valve (DHWT-SWG-01 accessory)
10	DHWT heater (integrated with DHWT)
11	LCD controller (integrated with DHWT)

### ◆ Two space heating (High & Low water temperature) (Installation example 3)

Two space heating (High & Low water temperature): When the split air to water heat pump is connected to two different heating circuits, circuit 1 will be direct (high temperature for radiator operation) and circuit 2 will be a mixing circuit in order to have a second temperature control using mixing valve motor (low temperature for floor heating operation). Additionally, a motorized valve must be added in order to close the direct circuit when it is not in use. In order to get these two water temperature levels (high and low), a mixing station is required. This mixing station is controlled using the indoor unit by means of an additional mixing valve motor and additional water sensor. Optional Room Thermostat. The necessary LCD controller is supplied as accessory.

#### **i** NOTE

- **When YUTAKI S80 is working with two space heating applications (High & Low water temperature), it is necessary to install the 2nd temperature kit accessory (ATW-2KT-01) and the following accessories:**
  - Water temperature sensor for second temperature control (ATW-WTS-02Y)
  - Mixing valve motor (ATW-MVM-01)
  - Aquastat for heating floor protection (ATW-AQT-01)
- **Additionally, the Auxilliary output signal box accessory (ATW-AOS-01) is available to control the field supplied Motorized valve for the direct circuit.**

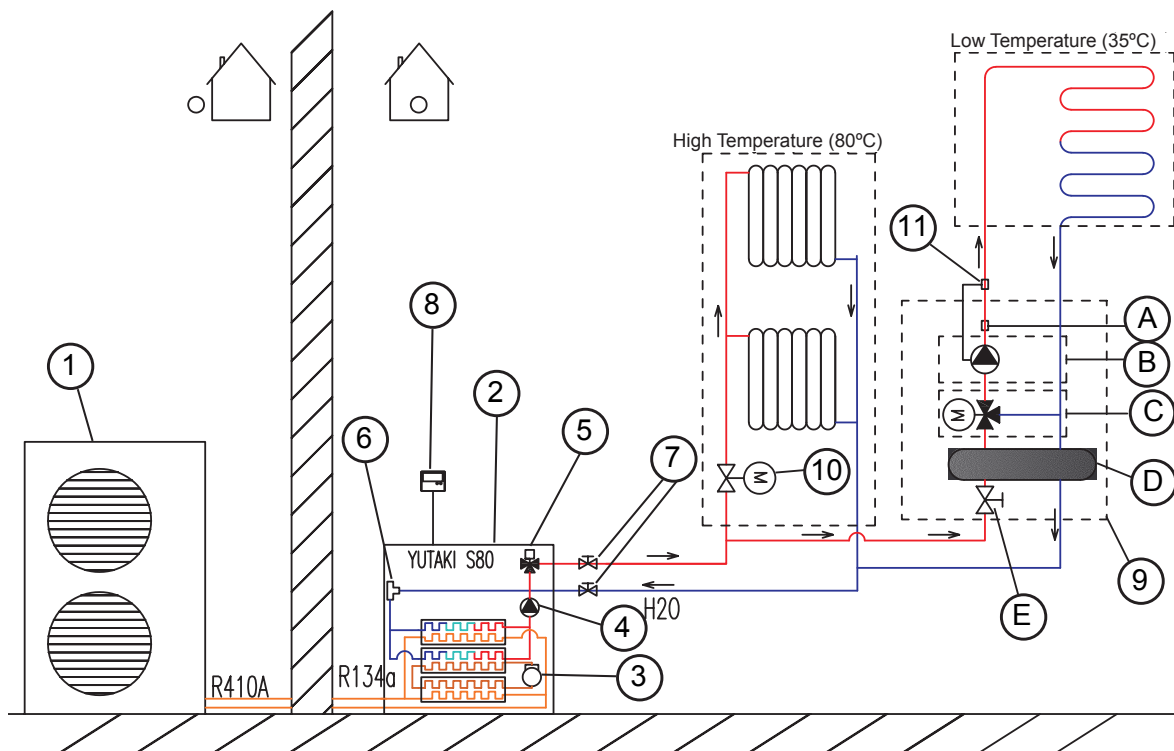

Item	Description
1	Outdoor unit
2	Indoor unit
3	R134a compressor
4	Water pump
5	3-way valve
6	T-branch
7	Shut-off valves (field supplied)

Item	Description
8	LCD controller (accessory)
9	Second temperature kit (ATW-2KT-01 accessory)
10	Motorized valve (field supplied)
11	Aquastat (ATW-AQT-01 accessory)

Item	Description
A	2nd Water Temperature sensor (ATW-WTS-02 accessory)
B	Secondary water pump
C	Mixing valve
D	Hydraulic separator
E	Shut-off valve

**◆ Two space heating (High & Low water temperature) and DHW Tank (Installation example 4)**

Two space heating applications (High & Low water temperature) and DHW Tank: When the split air to water heat pump is connected to two different heating circuits, circuit 1 will be direct (high temperature for radiator operation) and circuit 2 will be a mixing circuit in order to have a second temperature control using mixing valve motor (low temperature for floor heating operation). Additionally, a motorized valve must be added in order to close direct circuit when not in use. In order to get these two water temperature levels (high and low), a mixing station is required. This mixing station is controlled using the indoor unit by means of an additional mixing valve motor and additional water sensor. Domestic Hot Water Tank is heated by Heat Pump. The space heating and domestic hot water tank operation is alternated (or heating or DHW tank). Optional room thermostat. The LCD is integrated with the DHW Tank.

**i NOTE**

- **When YUTAKI S80 is working with two space heating applications (High & Low water temperature), it is necessary to install the 2nd temperature kit accessory (ATW-2KT-01) and the following accessories:**
  - Water temperature sensor for second temperature control (ATW-WTS-02Y)
  - Mixing valve motor (ATW-MVM-01)
  - Aquastat for heating floor protection (ATW-AQT-01)
- **Additionally, the Auxilliary output signal box accessory (ATW-AOS-01) is available to control the field supplied Motorized valve for the direct circuit.**

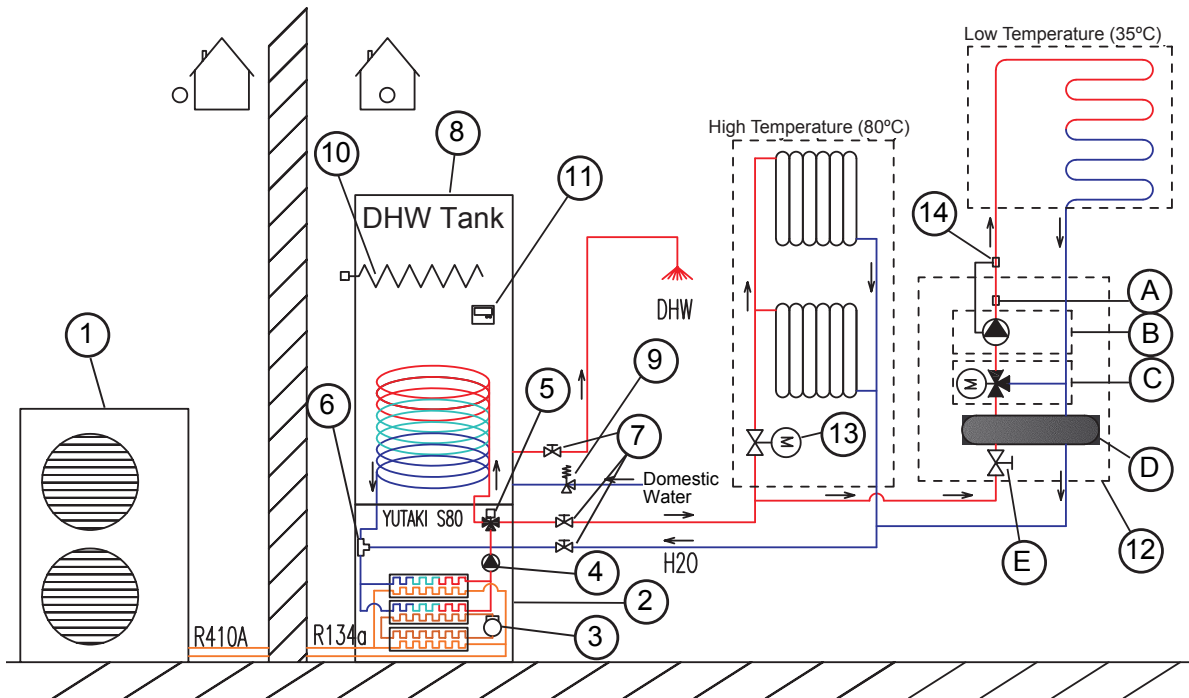

Item	Description
1	Outdoor unit
2	Indoor unit
3	R134a compressor
4	Water pump
5	3-way valve
6	T-branch
7	Shut-off valves (field supplied)
8	Domestic hot water tank

Item	Description
9	Security valve (DHWT-SWG-01 accessory)
10	DHWT heater (integrated with DHWT)
11	LCD controller (integrated with DHWT)
12	Second temperature kit (ATW-2KT-01 accessory)
13	Motorized valve (field supplied)

Item	Description
14	Aquastat (ATW-AQT-01 accessory)
A	2nd Water Temperature sensor (ATW-WTS-02 accessory)
B	Secondary water pump
C	Mixing valve
D	Hydraulic separator
E	Shut-off valve

### 11.2.2 Additional combinations

#### ◆ Electric heater complement (Installation example 5)

Two space heating applications (High & Low water temperature) + Combination with Electric heater + optional Domestic Hot Water Tank: Two space heating application with a Room Thermostat as an option heated by Heat Pump and supplemented by 3-stage electrical heater (as accessory) to provide additional heating capacity to the system (mono-energetic system). Optional Domestic Hot Water Tank is heated by Heat Pump. The LCD is integrated with the DHW Tank or supplied as necessary accessory if indoor unit is alone.

#### **i** NOTE

**When YUTAKI S80 is working in Mono-energetic system (with electric heater) the electric heater accessory is available (WEH-6E). Additional water sensor (Two3) is also necessary. Use the ATW-WTS-02Y universal water sensor accessory if needed.**

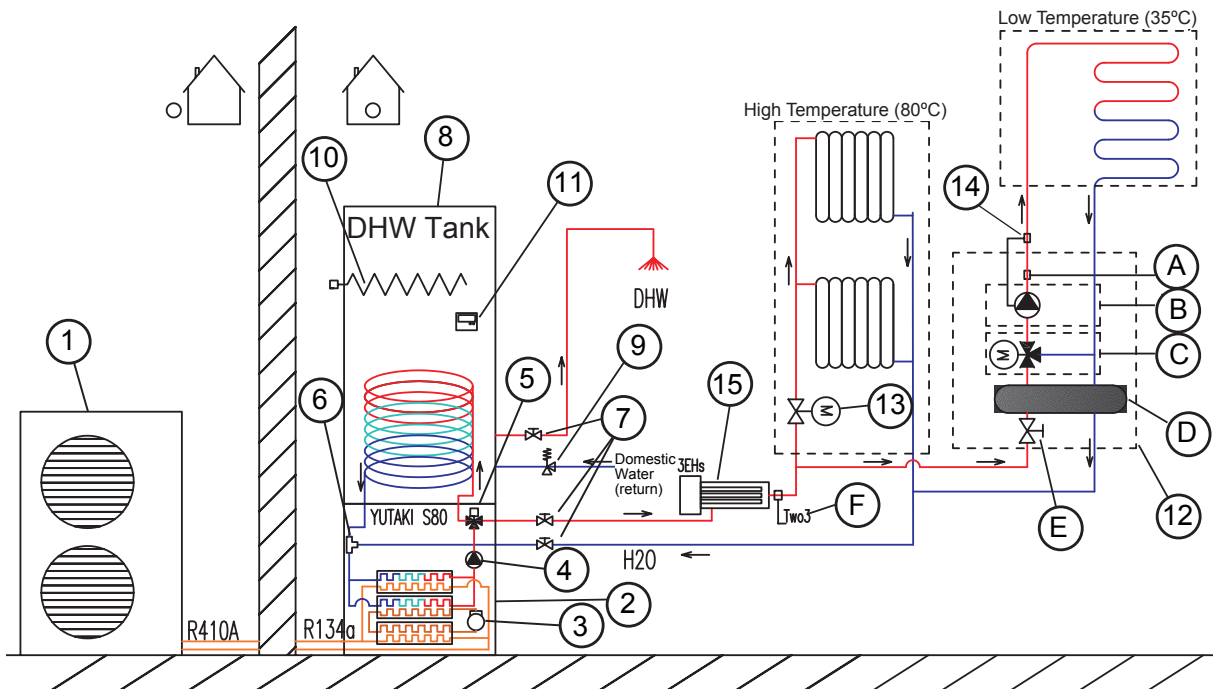

Item	Description
1	Outdoor unit
2	Indoor unit
3	R134a compressor
4	Water pump
5	3-way valve
6	T-branch
7	Shut-off valves (field supplied)
8	Domestic hot water tank
9	Security valve (DHW-T-SWG-01 accessory)

Item	Description
10	DHWT heater (integrated with DHWT)
11	LCD controller (integrated with DHWT)
12	Second temperature kit (ATW-2KT-01 accessory)
13	Motorized valve (field supplied)
14	Aquastat (ATW-AQT-01 accessory)
15	Electric heater (WEH-6E accessory)

Item	Description
A	2nd Water Temperature sensor (ATW-WTS-02 accessory)
B	Secondary water pump
C	Mixing valve
D	Hydraulic separator
E	Shut-off valve
F	Universal water sensor (Two3) (ATW-WTS-02Y accessory)

◆ **Boiler complement (Installation example 6)**

Installation with alternating space heating and Boiler combination + optional Domestic Hot Water Tank: Space heating application with optional Room Thermostat heated alternating Heat Pump and boiler combination. Optional Domestic Hot Water Tank is heated by Heat Pump. The LCD is integrated with the DHW Tank or supplied as accessory if indoor unit is alone. The LCD is integrated with the DHW Tank or supplied as necessary accessory if indoor unit is alone.

**i NOTE**

- When YUTAKI S80 is working in Alternating Bi-valent system (with boiler), a hydraulic separator or buffer tank has to be used to ensure proper hydraulic balancing. Use the ATW-HSK-01 accessory if needed. Additional Water pump (WP3) and water sensor (Two3) (ATW-WTS-02Y accessory) are also necessary.
- When YUTAKI S80 is working in Alternating Bi-valent system (with boiler) install 2 water check valves (non-return) at the water inlet of the indoor unit and boiler. Use the ATW-WCV-01 accessory if needed.

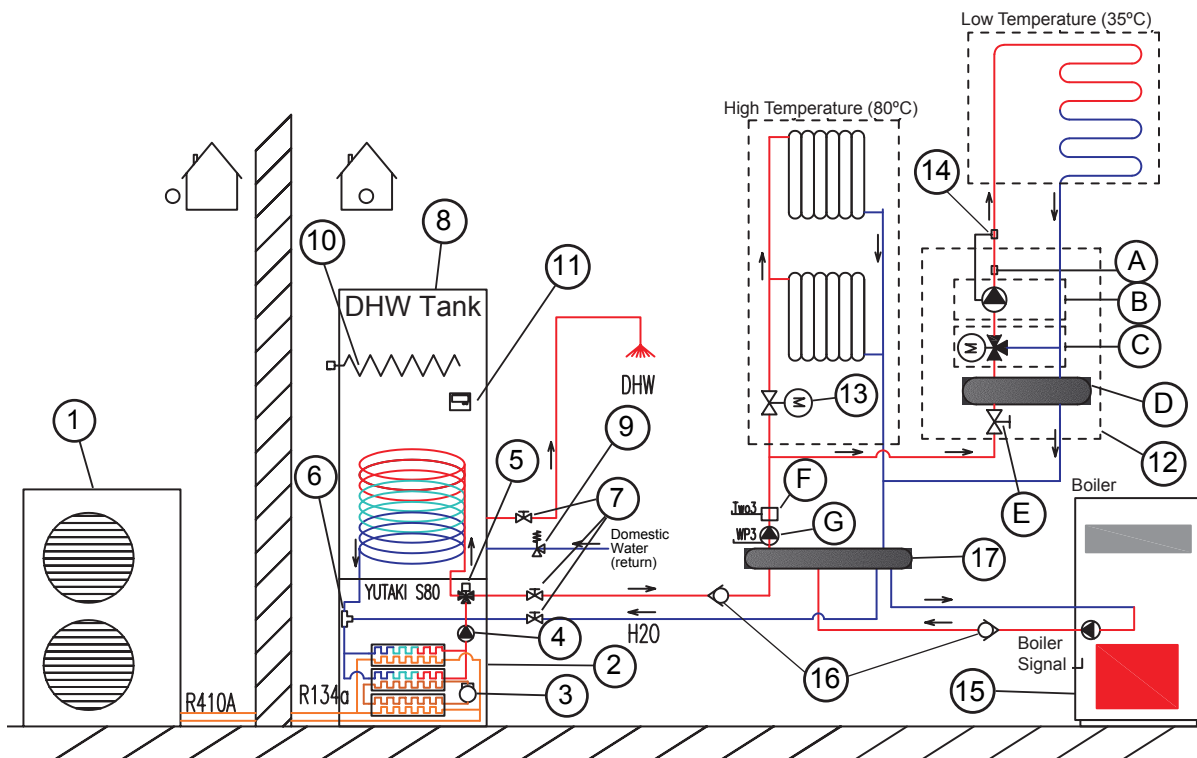

Item	Description
1	Outdoor unit
2	Indoor unit
3	R134a compressor
4	Water pump
5	3-way valve
6	T-branch
7	Shut-off valves (field supplied)
8	Domestic hot water tank
9	Security valve (DHWT-SWG-01 accessory)
10	DHWT heater (integrated with DHWT)

Item	Description
11	LCD controller (integrated with DHWT)
12	Second temperature kit (ATW-2KT-01 accessory)
13	Motorized valve (field supplied)
14	Aquastat (ATW-AQT-01 accessory)
15	Boiler (field supplied)
16	Water check valve (ATW-WCV-01 accessory)
17	Hydraulic separator (ATW-HSK-01 accessory)

Item	Description
A	2nd Water Temperature sensor (ATW-WTS-02 accessory)
B	Secondary water pump
C	Mixing valve
D	Hydraulic separator
E	Shut-off valve
F	Universal water sensor (Two3) (ATW-WTS-02Y accessory)
G	Water pump 3 (WP3) (field supplied)

◆ **Solar combination (Installation example 7)**

**i NOTE**

**Solar combination is not available when the HITACHI domestic hot water tank is integrated over the indoor unit.**

Two space heating applications (High & Low water temperature) + Domestic Hot Water Tank + Solar combination + Heating complement (Boiler or Electric heater combination): Two space heating application with a Room Thermostat as an option heated by Heat Pump and alternating boiler or supplemented by 3-stage electrical heater. Domestic Hot Water Tank is heated by Heat Pump and also by free energy of the sun by means of a field supplied Solar panel and field supplied Solar Kit. The LCD is integrated with the DHW Tank.

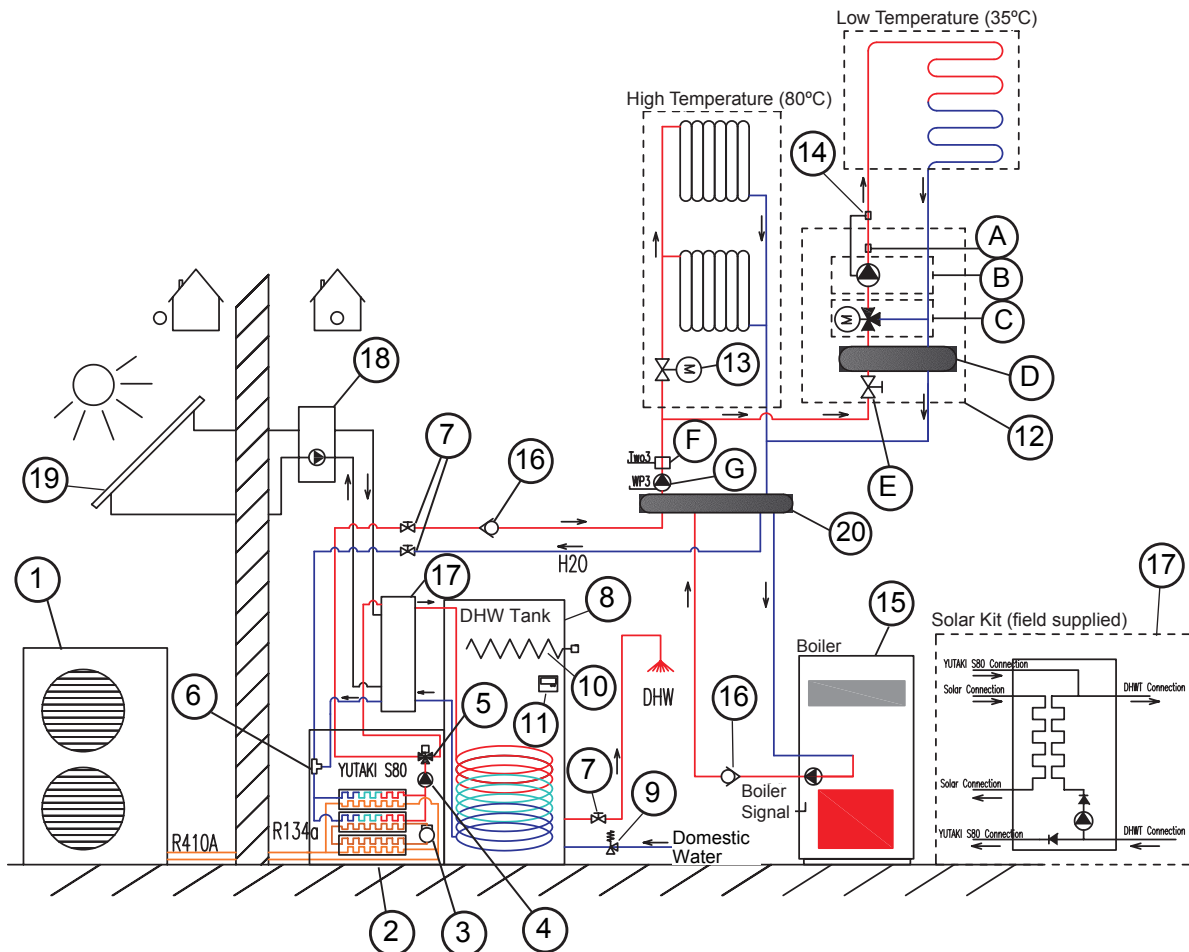

Item	Description
1	Outdoor unit
2	Indoor unit
3	R134a compressor
4	Water pump
5	3-way valve
6	T-branch
7	Shut-off valves (field supplied)
8	Domestic hot water tank
9	Security valve (DHWT-SWG-01 accessory)
10	DHWT heater (integrated with DHWT)

Item	Description
11	LCD controller (integrated with DHWT)
12	Second temperature kit (ATW-HSK-01 accessory)
13	Motorized valve (field supplied)
14	Aquastat (ATW-AQT-01 accessory)
15	Boiler (field supplied)
16	Water check valve (ATW-WCV-01 accessory)
17	Solar Kit (field supplied)
18	Solar pump & control (field supplied)

Item	Description
19	Solar panel (field supplied)
20	Hydraulic separator (ATW-HSK-01 accessory)
A	2nd Water Temperature sensor (ATW-WTS-02 accessory)
B	Secondary water pump
C	Mixing valve
D	Hydraulic separator
E	Shut-off valve
F	Universal water sensor (Two3) (ATW-WTS-02Y accessory)
G	Water pump 3 (WP3) (field supplied)



◆ **Swimming pool combination (Installation example 8)**

Two space heating applications (High & Low water temperature) + optional Domestic Hot Water Tank + Swimming pool combination + Heating complement (Boiler or Electric heater combination): Two space heating application with a Room Thermostat as an option and swimming pool space heated by Heat Pump and alternating boiler or supplemented by 3-stage electrical heater. Swimming pool is connected to the main circuit through a 3-way valve (ATW-3WV-01/02 accessory) and a heat exchanger (field supplied). Domestic Hot Water Tank is heated by Heat Pump. The LCD is integrated with the DHW Tank or supplied as necessary accessory if indoor unit is alone.

**i NOTE**

**When YUTAKI S80 is working with a swimming pool the 3-way valve accessory is needed (ATW-3WV-01 or ATW-3WV-02).**

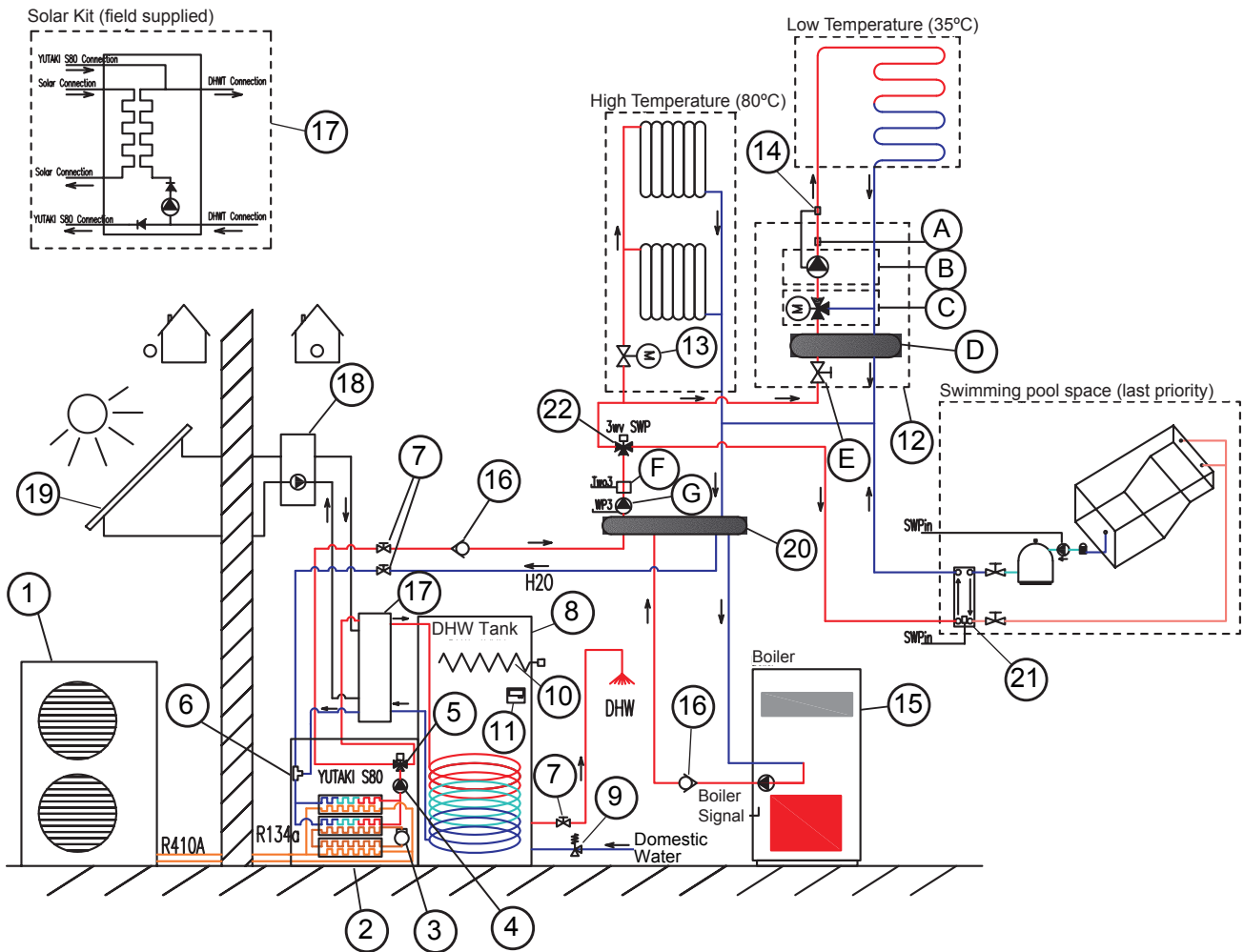

Item	Description
1	Outdoor unit
2	Indoor unit
3	R134a compressor
4	Water pump
5	3-way valve
6	T-branch
7	Shut-off valves (field supplied)
8	Domestic hot water tank
9	Security valve (DHWT-SWG-01 accessory)
10	DHWT heater (integrated with DHWT)
11	LCD controller (integrated with DHWT)

Item	Description
12	Second temperature kit (ATW-2KT-01 accessory)
13	Motorized valve (field supplied)
14	Aquastat (ATW-AQT-01 accessory)
15	Boiler (field supplied)
16	Water check valve (ATW-WCV-01 accessory)
17	Solar Kit (field supplied)
18	Solar pump & control (field supplied)
19	Solar panel (field supplied)
20	Hydraulic separator (ATW-HSK-01 accessory)

Item	Description
21	Swimming pool heat exchanger (field supplied)
22	3-way valve (ATW-3WV-01/02 accessory)
A	2nd Water Temperature sensor (ATW-WTS-02 accessory)
B	Secondary water pump
C	Mixing valve
D	Hydraulic separator
E	Shut-off valve
F	Universal water sensor (Two3) (ATW-WTS-02Y accessory)
G	Water pump 3 (WP3) (field supplied)





# 12. Optional functions

## Index

12.1. Indoor unit .....	148
12.1.1. Optional functions.....	148
12.1.2. Optional external output signals (by 7-segment display).....	149
12.2. Outdoor unit.....	149
12.2.1. Optional functions.....	149

## 12.1 Indoor unit

### 12.1.1 Optional functions

	Optional function	Explanation
From LCD user's interface	Floor screed drying function (only circuit 2)	The screed function is used exclusively for the process of drying of newly applied screed on floor heating system. When user activates screed function, the water set point follows a predetermined schedule.
	Automatic summer switch-OFF	The system will switch OFF the heating mode when the daily average outdoor temperature of previous day rises above certain value at the summer switch-OFF activation temperature, avoiding to provide heating at high outdoor temperatures.
	Pump and motorized valve seizure protection	This function prevents the components of being stuck during long periods of inactivity by running every week the components during a short period.
	DHW anti-Legionella protection	In order to help protect against Legionella into the DHW system, it is available an specific setting which will raise up the DHW set point periodically (by the DHW tank electric heater or by a boiler) over the normal DHW tank temperature setting.
	Electrical tariff input	This function allows an external tariff switch device to switch OFF the heat pump during peak electricity demand period. When the system is working in combination with Boiler, the boiler will be switched ON to provide the necessary heating.
	Hydraulic separator combination	When the indoor unit's water pump is not sized for heating installation (small water pump) or when the system is configured to alternate when a boiler, an hydraulic separator or buffer tank must be used to ensure proper hydraulic balancing. In this case, the hydraulic separator option can be enabled by the LCD user's interface.
From dip-switch setting	Anti freeze control (winter operation)	When YUTAKI S80 is operating in winter, if the outlet water temperature is 5°C or lower, and the unit remains in Thermo OFF Operation (and water pump OFF), the water pump operates to protect the unit and pipes installation from freezing. This control is released when the water outlet temperature becomes 7°C or higher. It function needs a dip-switch setting.
	Electrical heater or boiler emergency mode	In the event of outdoor unit failure, the required heating can be provided by the electric heater or by the boiler, by means of a dip-switch setting.
	One step heater for three phase imbalance option	In order to prevent 3-phase imbalance by the electric heater steps, this option can be used to switch all 3 steps at the same time, by means of a dip-switch setting.   <b>NOTE</b> <b><i>This function only applies when power source of the indoor unit is 3-phase (3N~ 400V 50Hz).</i></b>
	2nd. outdoor temperature sensor accessory	In situations where the heat pump is located into a location where is not suitable a temperature measurement to the system, it is available the 2nd. outdoor ambient temperature sensor. YUTAKI S80 can use the two outdoor temperature sensors (Outdoor unit ambient temperature and Auxiliary ambient temperature) for the two space heating circuits. It is necessary a dip-switch setting to use this temperature value instead of the outdoor ambient temperature value.
From 7-segment	Available four external outputs signals	There are available four output optional signals that provide four optional functions of the system, programmed on the indoor unit PCB.   <b>NOTE</b> <b><i>In order to make easy the electrical connection works, HITACHI offers as accessory a relay board for the additional output signals (Auxiliary output signal box ATW-AOS-01).</i></b>

 **NOTE**

**For the detailed information about optional functions, please refer to the Service Manual.**

### 12.1.2 Optional external output signals (by 7-segment display)

Unit switches to this mode when DSW4-8 is turned ON during unit stoppage.

The unit has the following described optional signals:

Code	Name	Description	Port
01	Operation signal	This signal allows control of the machine status at all times; it is very useful for centralized applications. The signal will be enabled when Thermo ON operation	CN7b / 1-3
02	Alarm signal	This signal allows activation of mechanisms that protect from and warn of possible failures in the unit. The signal will be enabled when the unit is in alarm (indoor or outdoor)	CN7b / 1-4
03	Not available	-	CN7b / 1-5
04	Thermo-OFF signal during circuit 1	Signal is enabled when circuit 1 is operating in Demand-OFF and circuit 2 in Thermo ON. The signal will be enabled when Demand OFF in circuit 1 and circuit 2 in Thermo ON.	CN7b / 1-6

## 12.2 Outdoor unit

### 12.2.1 Optional functions

Outdoor unit has the following signals that are described in the following table. These signals are set up through the PCB of the outdoor unit.

#### ◆ Output signals (by 7-segment)

Ind.	Output signal	Application	Port
0	N° setting application	N° setting	-
01	Operation signal	This signal allows to pick up the machine's operation signal. This is very useful to start up additional systems such as humidifiers, fans and other additional air-conditioning systems.	CN7
02	Alarm signal	This signal picks up the machine's alarm. This is very useful to warn that an alarm has been tripped.	CN7
03	Compressor ON signal	This signal allows to pick up the compressor's operation signal. It is very useful for checking signals during remote-control operation and for the interlock of the outdoor unit.	CN7
04	Defrost operation signal	This signal allows to pick up the defrosting of the unit. This is very useful to know how the indoor unit is operating if there is an abnormal situation. .	CN7



#### NOTE

**Do not set same function (01~04) to multiple input port.**



# 13. Troubleshooting

## Index

13.1. Troubleshooting procedure by alarm code.....	152
13.1.1. Alarm display .....	152
13.1.2. Alarm codes.....	153

## 13.1 Troubleshooting procedure by alarm code

### 13.1.1 Alarm display

#### ◆ Alarm code indication on LCD controller

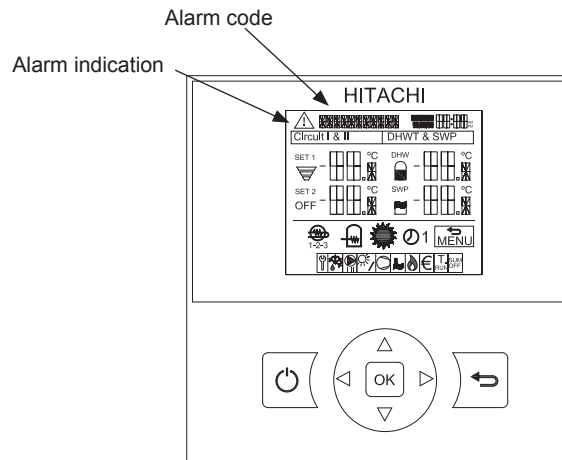

#### ◆ Alarm code indication on 7 segment

##### Indoor unit

Position of the 7 segment at the indoor PCB1&3:

##### RWH-(4-6)FS(V)NFE

- The 7 segment at the indoor PCB1 will show the alarms from the outdoor unit, the hydraulic circuit and the 1st cycle.
- The 7 segment at the indoor PCB3 will show the alarms from the 2nd cycle.

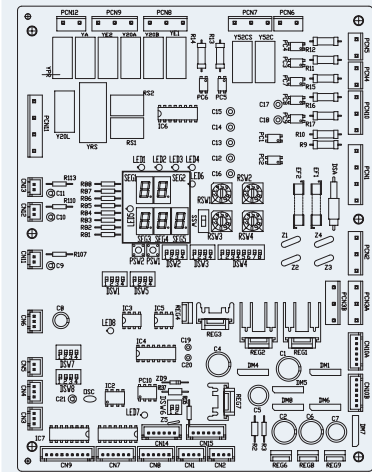

##### Outdoor unit

Position of the 7 segment at the outdoor PCB:

##### RAS-(4-6)H(V)RNME-AF

- The 7 segment at the outdoor PCB will show the alarms from the outdoor unit.

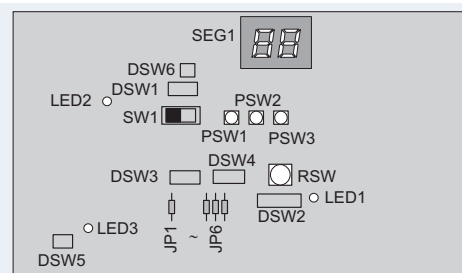



### 13.1.2 Alarm codes

LCD display	7 segment display	Origin	Detail of abnormality	Main factors
02	02	Outdoor	Activation of outdoor unit protection device (Except for alarm code 42)	High pressure interrupting device activated
03	03	Outdoor - 1st cycle	Transmission error	Outdoor fuse meltdown, Indoor/outdoor connection wiring (breaking, wiring error, etc.)
04	04	Outdoor	Inverter transmission abnormality	Control PCB – Inverter PCB connection wiring (breaking, wiring error, etc.)
05	05	Outdoor	Power phase detection abnormality	Power source wiring open phase in indoor units
06	06	Outdoor	Undervoltage, overvoltage	Outdoor PCB abnormality, inverter PCB abnormality, DM, CB abnormality
07	07	Outdoor	Abnormal decrease of discharge gas super-heat degree	Excessive refrigerant, expansion valve open-locked, fan motor locked
08	08	Outdoor	Compressor-Top temperature over-increase	Shortage or leakage of refrigerant, piping clogging, fan motor lock
11	11	Hydraulic	Water inlet thermistor abnormally (THM <sub>WI</sub> )	Loose, disconnected, broken or short-circuited connector
12	12	Hydraulic	Water outlet thermistor abnormally (THM <sub>WO</sub> )	Loose, disconnected, broken or short-circuited connector
13	13	1st cycle	Indoor liquid pipe temperature thermistor abnormality (THM <sub>L</sub> )	Loose, disconnected, broken or short-circuited connector
14	14	1st cycle	Indoor gas pipe temperature thermistor abnormality (THM <sub>G</sub> )	Loose, disconnected, broken or short-circuited connector
15	15	1st cycle	Water outlet C2 thermistor abnormally (THM <sub>WO2</sub> )	Loose, disconnected, broken or short-circuited connector
16	16	1st cycle	Water DHWT thermistor abnormally (THM <sub>DHWT</sub> )	Loose, disconnected, broken or short-circuited connector
17	17	1st cycle	Water swimming pool thermistor abnormally (THM <sub>SWP</sub> )	Loose, disconnected, broken or short-circuited connector
18	18	1st cycle	Water outlet 3 thermistor abnormally (THM <sub>WO3</sub> )	Loose, disconnected, broken or short-circuited connector
20	20	Outdoor	Compressor-Top temperature thermistor abnormality	Loose, disconnected, broken or short-circuited connector
21	21	1st cycle	2nd ambient thermistor abnormally (THM <sub>AMB2</sub> )	Loose, disconnected, broken or short-circuited connector
22	22	Outdoor	Outdoor temperature thermistor abnormality	Loose, disconnected, broken or short-circuited connector
24	24	Outdoor	Outdoor heat exchanger liquid pipe thermistor abnormality	Loose, disconnected, broken or short-circuited connector
31	31	Outdoor	Indoor/Outdoor combination setting error	Outdoor/Indoor unit capacity setting error, indoor total capacity excessively large/small
35	35	Outdoor	Indoor unit number setting error	Indoor units with the same number exist in a refrigerant piping system
38	38	Outdoor	Outdoor protection detection circuit abnormality	Outdoor PCB abnormality, error in wiring to outdoor PCB
41	41	Outdoor	Pump down overload	Outdoor heat exchanger clogging/short circuit, broken outdoor fan
42	42	Outdoor	Heating overload	Outdoor heat exchanger clogging/short circuit, expansion valve close-locked
47	47	Outdoor	Suction pressure decrease prevention activated	Shortage or leakage of refrigerant, piping clogging, expansion valve close-locked, fan motor locked
48	48	Outdoor	Overload operation protection activation	Cycle abnormality, Inverter PCB abnormality, DM abnormality, heat exchanger clogging, etc.
51	51	Outdoor	Inverter current sensor abnormality	Error in CT wiring, outdoor PCB abnormality, Inverter PCB abnormality
53	53	Outdoor	Inverter module error	Compressor, ISPM abnormality, heat exchanger clogging, etc.
54	54	Outdoor	Inverter fin temperature abnormality	Fin thermistor abnormality, heat exchanger clogging, fan motor abnormality
55	55	Outdoor	Inverter non-operation	Inverter not operating or broken

LCD display	7 segment display	Origin	Detail of abnormality	Main factors
57	57	Outdoor	Abnormality of fan motor protection (DC fan motor)	
59	59	Outdoor	Inverter fin temperature thermistor abnormality	Loose, disconnected, broken or short-circuited connector
63	63	Communication	Transmission error between central and indoor communication	Indoor fuse meltdown, indoor/central connection wiring (breaking, wiring error, etc.)
EE (100)	EE	Outdoor	Compressor factor alarm	Alarm to notify damage to compressor occurs 3 times within 6 hours
70	70	1st cycle	Hydraulic alarm	Water pressure or water flow is not detected in the hydraulic cycle
73	73	1st cycle	Mixing over-temperature limit protection for mixed circuit	Circuit 2 supply temperature > Target temperature + offset
74	74	1st cycle	Unit over-temperature limit protection	Water supply temperature (Two) is 5°C more than maximum water circuit temperature for 20 sec.
75	75	Hydraulic	Freeze protection by cold water inlet temperature detection	The inlet water temperature is lower than 2 °C.
76	76	Hydraulic	Freeze protection stop by indoor liquid temperature thermistor	
77	77	1st cycle	Opentherm communication failure	No Opentherm communication for a continuous period of 1 minute
78	78	1st cycle	RF communication failure	There is no communication for 1 hour with one or two RF receivers which are bound to the RF-Bridge.
79	79	1st cycle - outdoor	Unit capacity setting error	There is no concordance between indoor outdoor unit capacity
80	80	1st cycle - LCD	LCD H-link transmission error	No H-LINK communication for a continuous period of 1 minute between Indoor and LCD User control by connection wiring (breaking, wiring error, etc.)
101	02↔H1	2nd cycle	Activation of high pressure switch	The high pressure (Pd) is higher than 3.0 MPa.
102	02↔h1	2nd cycle	Activation of protection control for excessively high pressure	The high pressure (Pd) is higher than 2.78 MPa during 10 seconds.
103	02↔L1	2nd cycle	Activation of protection control for excessively low pressure	The suction pressure (Ps) is lower than 0.15 MPa during 1.5 minutes.
104	02↔l1	2nd cycle	Activation of low pressure control	The suction pressure (Ps) is lower than 0.1 MPa during 3 seconds.
105	02↔E1	2nd cycle	Excessively low pressure difference	The pressure ratio calculated from high pressure (Pd) and low pressure (Ps) is lower than 1.8 MPa during 3 minutes.
106	02↔61	2nd cycle	Excessively high discharge gas temperature	The discharge gas temperature is increased to 120 °C during 10 minutes or is higher than 140 °C at least 5 seconds.
124	21	2nd cycle	Failure of refrigerant evaporation temperature thermistor	The refrigerant evaporation temperature thermistor is short-circuited or cut.
125	22	2nd cycle	Failure of ambient temperature thermistor	The ambient temperature thermistor is short-circuited or cut.
126	23	2nd cycle	Failure of discharge gas temperature thermistor	The discharge gas temperature thermistor is short-circuited or cut.
127	24	2nd cycle	Failure of refrigerant liquid temperature thermistor	The refrigerant liquid temperature thermistor is short-circuited or cut.
128	26	2nd cycle	Failure of suction gas temperature thermistor	The suction gas temperature thermistor is short-circuited or cut.
129	27	2nd cycle	Failure of discharge gas pressure sensor	The high pressure sensor is short-circuited or cut.
130	28	2nd cycle	Failure of suction gas pressure sensor	The low pressure sensor is short-circuited or cut.
132	04	2nd cycle	Abnormal transmission between Inverter PCB and Main PCB	The communication between Main PCB (PCB1) and Inverter (DIP - IPM/ISPM) is not performed correctly during 30 seconds.
134	05	2nd cycle	Abnormality of Power Supply Phase	The power source phases are reversely connected or one phase is not connected.

LCD display	7 segment display	Origin	Detail of abnormality	Main factors
135	30	2nd cycle	Incorrect PCB Setting	Wrong settings are performed in DIP switches on PCB.
136	40	2nd cycle	Incorrect operation	Wrong settings are performed in DIP switch on PCB or prohibited operation is performed.
151	06	2nd cycle	Excessively low voltage or excessively high voltage for the inverter	The voltage between terminal "P" and "N" of ISPM is insufficient.
152	51	2nd cycle	Abnormal operation of the current sensor	The compressor frequency is maintained at 15 - 18 Hz after the compressor's start up, one of the absolute values of the running current at each phase U+, U-, V+ and V- is lower than 1.5 A.
153	52	2nd cycle	Activation of protection for inverter instantaneous over current	The compressor current is higher than the set value.
154	53	2nd cycle	Transistor module protection activation	The transistor module detects an abnormality 3 times in 30 minutes.
155	54	2nd cycle	Increase in the inverter fin temperature	The temperature of the thermistor for inverter fin exceeds 100 °C.





Hitachi Air Conditioning Products Europe, S.A.  
Ronda Shimizu, 1 - Políg. Ind. Can Torrella  
08233 Vacarisses (Barcelona) España



Hitachi certifies that our products have met EU consumer safety, health and environmental requirements.



Hitachi Air Conditioning Products Europe, S.A. is certified with:  
ISO 9001 of AENOR, Spain for its Quality Management accordance with the standard  
ISO 14001 of AENOR Spain for its Environmental Management systems accordance with the standard.



Hitachi air conditioning products are manufactured according to:  
ISO 9001 of JQA, Japan for its Quality Management accordance with the standard  
ISO 14001 of JACO, Japan for its Environmental Management accordance with the standard.



HITACHI participates in the Eurovent Certification Programme; the certified data of certified models are listed in the Eurovent Certification Online Directory ([www.eurovent-certification.com](http://www.eurovent-certification.com)).